

SIMPLY CLEVER

ŠKODA



ŠKODA Octavia

OWNER'S MANUAL

Introduction

You have opted for a Škoda - our sincere thanks for your confidence in us.

Your new Škoda offers you a vehicle featuring the most modern engineering and a wide range of equipment which you will undoubtedly wish to use to the full during your daily motoring. That is why, we recommend that you read this Owner's Manual attentively to enable you to become familiar with your car and all that it offers as quickly as possible.

Please do not hesitate to contact your specialist garage or importer should you have any further questions or any problems regarding your vehicle which may arise. He will be ready at any time to receive your questions, suggestions and criticisms.

National legal provisions, which deviate from the information contained in these operating instructions, take precedence over the information contained in the operating instructions.

We wish you much pleasure with your Škoda and pleasant motoring at all times.

Your **Škoda** Auto



On-board literature

The on-board literature for your vehicle consists of this "**Owner's Manual**" as well as a "**Service schedule**" and a "**Help on the road**". There can also be a variety of other additional operating manuals and instructions on-board (e.g. an operating manual for the radio) depending on the vehicle model and equipment.

If one of the publications listed above is missing, please contact an authorised Škoda dealer immediately, where one will be glad to assist you in such matters.

One should note that the details given in the vehicle's technical documentation always take precedence over those in the Owner's Manual.

Owner's Manual

This Owner's manual describes **all possible equipment variants** but they are not indicated as special equipment, model variants or market-dependent equipment.

Consequently, this vehicle does **not need to contain all of the equipment components** described in this Owner's manual.

The scope of equipment for your vehicle is described in the sales documentation you were given when purchasing the car. More information is available from your Škoda dealer.

The **illustrations** can differ in minor details from your vehicle; they are only intended for general information.

In addition to information regarding all the controls and equipment, the Owner's Manual also contains important information regarding care and operation for your safety and also to retain the value of your vehicle. To provide you with valuable tips and aids. You will learn how you can operate your vehicle **safely, economically** and in an **environmentally** conscious way.

For safety reasons, please also pay attention to the information on accessories, modifications and replacement of parts ⇒ page 204.

The other chapters of the Owner's Manual are also important, however, for proper treatment of your car - in addition to regular care and maintenance - helps to retain its value and in many cases is also one of the conditions for possible warranty claims.

The Service schedule

contains:

- Vehicle data,
- Service intervals,
- Overview of the service work,
- Service proof,
- Confirmation of mobility warranty (only valid in certain countries)
- important information on the warranty.

The confirmations of the carried out service work are one of the conditions for possible warranty claims.

Please always present the Service schedule when you take your car to an authorised Škoda Service Partner.

If the Service schedule is missing or worn, please contact your authorised Škoda Service Partner, where your car is serviced regularly. You will receive a duplicate, in which the previously carried out service work are confirmed.

Help on the road

Contains the most important telephone numbers in individual countries as well as the addresses and telephone numbers of Škoda importers.

Contents

Layout of this Owner's Manual (explanations)

Using the system

Cockpit

Overview

Quick Reference Guide

Basic functions and important information

Instruments and warning lights

Overview of the instrument cluster

Engine revolutions counter

Speedometer

Coolant temperature gauge

Fuel gauge

Counter for distance driven

Service reminder indicator

Digital clock

Shift recommendation for changing gears

Multi-functional indicator (onboard computer)

MAXI DOT display (information display)

Auto Check Control

Warning lights

Unlocking and locking

Vehicle key

Child safety lock

Central locking system

Remote control

Synchronisation of the remote control

Anti-theft alarm system

Power windows

Electric sliding/tilting roof

Lights and Visibility

Lights

Interior lighting

Visibility

Windshield wiper and wash system

Rear-view mirror

Seats and Stowage

Front seats

Adjusting front seats electrically

Head restraints

Middle rear head restraint

Rear seats

Pedals

Luggage compartment

Net partition (Estate)

The roof rack

Cup holder

Note holder

Ashtray

Cigarette lighter, power sockets

Storage compartments

Overview

Storage compartment on the front passenger side

Cooling of storage compartment on front passenger side

Storage compartment on the driver's side

Storage compartment on the dash panel

Storage compartment in front centre console

Storage net on the front centre console

Stowage compartment for spectacles

Storage compartment in the front doors

Stowage compartment below front passenger seat

Front seat armrest with storage compartment

Rear seat armrest with storage compartment

Stowage compartment in rear centre console

Seat backrest with opening for skis

Through-loading bag

Side compartment

Stowage compartment behind the rear seats (estate car)

Clothes hooks

Heating and air conditioning system

Introduction

Description and information

Using the air conditioning system economically

Operational problems

Air outlet vents

Heating

Air conditioning system (manual air conditioning system)

Climatronic (automatic air conditioning)

Auxiliary heating (auxiliary heating and ventilation)

Starting-off and Driving

Setting steering wheel position

Ignition lock

Starting the engine

Switching off the engine

Shifting (manual gearbox)

Handbrake

Rear parking aid

Front and rear parking aid

Cruise control system (CCS)

"(START-STOP)"

Automatic gearbox

Automatic gearbox

Communication

Multifunction steering wheel

Mobile phones and two-way radio systems

Universal telephone preinstallation GSM II

Voice control

Universal telephone preinstallation GSM III

Voice control	134	Tyre pressure monitoring system	166	Breakdown assistance	205
Internet connection	135	Diesel particle filter (diesel engine)	167	Breakdown assistance	205
Music playback via Bluetooth®	135	Driving and the Environment	168	First-aid box and Warning triangle (Octavia)	205
Multimedia	135	The first 1 500 kilometres and afterwards	168	First-aid box and warning triangle (Estate car)	205
Safety	137	Catalytic converter	168	Fire extinguisher	205
Passive Safety	137	Driving in an economical and environmentally conscious manner	169	Vehicle tool kit	206
Basic information	137	Environmental compatibility	172	Spare wheel	206
Correct seated position	138	Motoring abroad	173	Changing a wheel	207
Seat belts	141	Avoiding damage to your vehicle	173	Tyre repair kit	210
Why seat belts?	141	Driving through bodies of water on roads	173	Jump-starting	213
The physical principle of a frontal collision	141	Towing a trailer	175	Towing the vehicle	214
Important safety information regarding the use of seat belts	142	Towing a trailer	175	Fuses and light bulbs	217
How are seat belts correctly fastened?	143	General Maintenance	177	Electric fuses	217
Airbag system	145	Taking care of your vehicle and cleaning the vehicle	177	Bulbs	220
Description of the airbag system	145	General	177	Technical data	227
Front airbags	146	Care of the exterior of vehicle	177	Technical Data	227
Side airbags	148	Care of the interior of vehicle	181	General information	227
Head airbags	150	Fuel	183	Used abbreviations	227
Deactivating an airbag	151	Petrol	183	Performances	227
Transporting children safely	153	Biofuel Ethanol E85	183	Weight	227
What you should know about transporting children?	153	Diesel	185	Identification details	228
Child seat	155	Refuelling	185	Fuel consumption according to the ECE standards and EU guidelines	228
Attaching a child seat using the "ISOFIX" system	158	Inspecting and Replenishing	187	Dimensions	229
Attaching child seat using the "Top Tether" system	158	Engine compartment	187	Engine oil specifications	230
Driving Tips	161	Engine oil	189	Engine 1.2 l/77 kW TSI - EU5	232
Intelligent Technology	161	Cooling system	191	Engine 1.4 l/59 kW - EU4, EU5	233
Electronic stability programme (ESP)	161	Brake fluid	193	Engine 1.4 l/90 kW TSI - EU5	234
Brakes	163	Battery	194	Engine 1.6 l/75 kW - EU2, EU4, EU5	235
Brake booster	164	Windshield washer system?	197	Engine 1.8 l/118 kW TSI - EU5, EU2 DDK (1.8 l/112 kW TSI - EU5)	236
Antilock brake system (ABS)	164	Wheels and Tyres	199	Engine 2.0 l/147 kW TSI - EU5, EU2 DDK	237
Brake Assist	165	Wheels	199	Engine 1.6 l/77 kW TDI CR - EU5	238
Uphill Start Assist	165	Accessories, changes and replacement of parts	204	Engine 1.9 l/77 kW TDI PD - EU4	239
Electromechanical power steering	165	General	204	Engine 2.0 l/81 kW TDI CR - EU4, EU5	240

Engine 2.0 I/103 kW TDI CR - EU4, EU5	241
Engine 2.0 I/125 kW TDI CR - EU5	242
Index	243

Layout of this Owner's Manual (explanations)

The Owner's Manual has been systematically designed, in order to make it easy for you to find and absorb the information you require.

Chapters, table of contents and subject index

The text of the Owner's manual is divided into relatively short sections which are combined into easy-to-read **chapters**. The chapter you are reading at any particular moment is highlighted at the bottom right of the page.

The **Table of contents** is arranged according to the chapters and the detailed **Subject index** at the end of the Owner's Manual helps you to rapidly find the information you are looking for.

Sections

The majority of **Sections** apply to all models.

Since there is a wide range of different equipment and options available it is clearly unavoidable, despite dividing the contents into sections, that mention may be made of equipment which is not fitted to your vehicle.

Brief information and instructions

Each section has a **Heading**.

This is followed by **Brief information** (in large italic lettering), which tells you the subject which is dealt with in this section.

Most of the illustrations are accompanied by an **Instruction** (in relatively large letters) which explains to you in a straightforward way the action you have to take. **Work steps** which have to be carried out are illustrated with a hyphen.

Direction indications

All direction indications such as "left", "right", "front", "rear" relate to the direction of travel of the vehicle.

Explanation of symbols

■ End of a section.

► The section is continued on the next page.

Notes

All four kinds of notes, which are used in the text, are always stated at the end of the respective section.



WARNING

The most important notes are marked with the heading **WARNING**. These **WARNING** notes draw your attention to a serious risk of accident or injury. While reading the text you will frequently encounter a double arrow followed by a small warning symbol. This symbol is intended to draw your attention to a **WARNING** note at the end of the section to which you must pay careful attention.



Caution

A **Caution** note draws your attention to the possibility of damage to your vehicle (e.g. damage to gearbox), or points out general risks of an accident.



For the sake of the environment

An **Environmental** note draws your attention to environmental protection aspects. This is where you will, for example, find tips aimed at reducing your fuel consumption.



Note

A normal **Note** draws your attention in a general way to important information. ■

Using the system

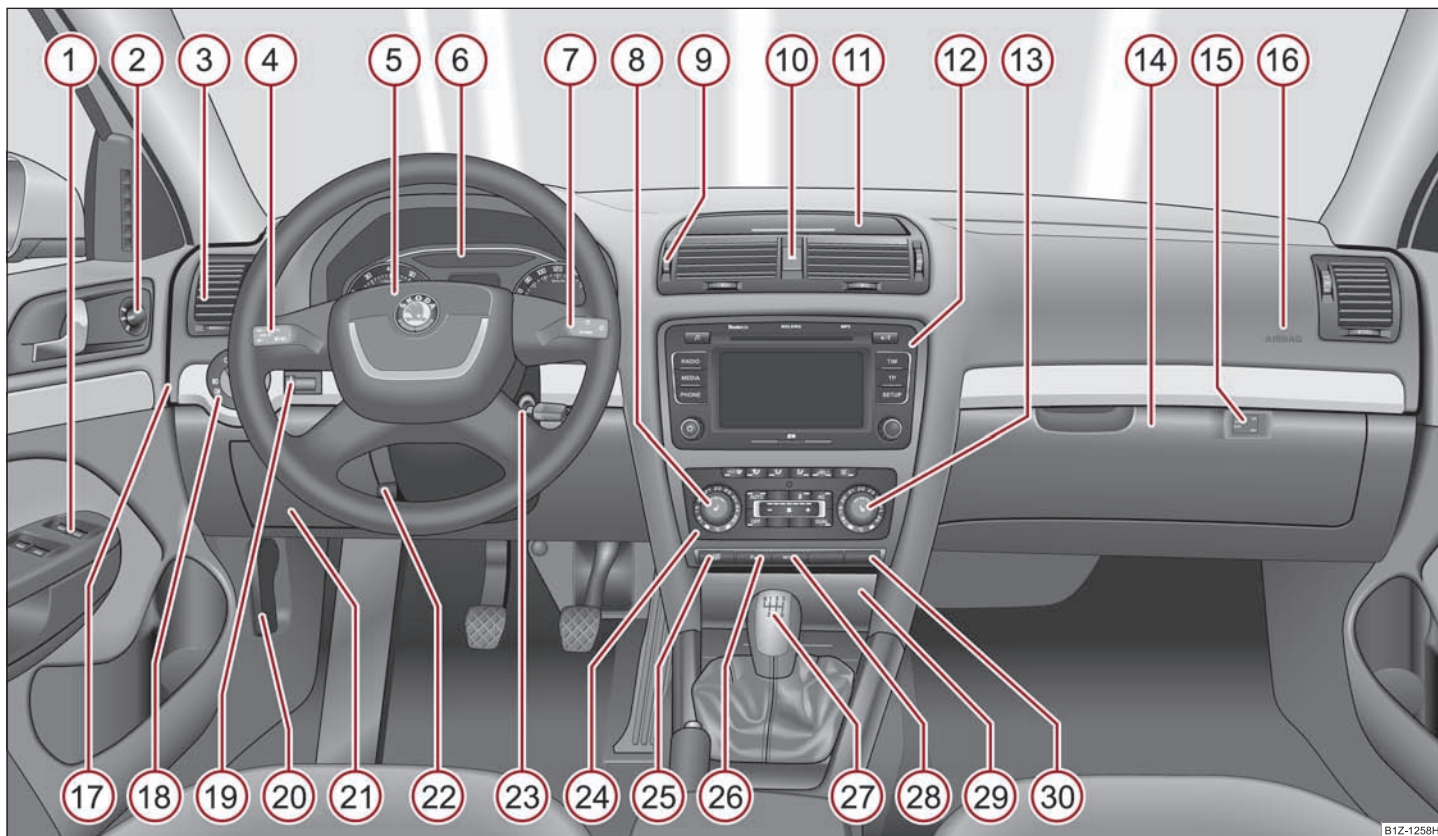

Fig.1 Cockpit

Cockpit

Overview

This overview will help you to quickly familiarise yourself with the displays and the control elements.

①	Power windows	43
②	Electric exterior mirror adjustment	62
③	Air outlet vents	91
④	Lever for the multi-functional switch:	
	– Turn signal light, headlight and parking light, headlight flasher	54
	– Speed regulating system	110
⑤	Steering wheel:	
	– with horn	
	– with driver airbag	146
	– with pushbuttons for radio, radio navigation system and mobile phone	120
⑥	Instrument cluster: Instruments and indicator lights	15
⑦	Lever for the multi-functional switch:	
	– Multi-functional indicator	18
	– Windshield wiper and wash system	58
⑧	Control dial for heating on the driver's seat	70
⑨	Air outlet vents	91
⑩	Switch for hazard warning lights	53
⑪	Storage compartment on the dash panel	83
⑫	Depending on equipment fitted:	
	– Radio	
	– Radio navigation system	70
⑬	Control dial for heating on the front passenger seat	70
⑭	Storage compartment on the front passenger side	82
⑮	Switch for the front passenger airbag (in front passenger storage compartment)	152
⑯	Front passenger airbag	146
⑰	Fuse box (on side of dash panel)	217
⑱	Light switch	48
⑲	Control dial for the instrument lighting and control dial for the headlight beam range regulation	52, 53

⑳	Bonnet release lever	187
㉑	Storage compartment on the driver's side	83
㉒	Lever for adjusting the steering wheel	104
㉓	Ignition lock	104
㉔	Depending on equipment fitted:	
	– Operating controls for the heating	92
	– Operation of air conditioning system	94
	– Operation of Climatronic	97
㉕	TCS switch	162
㉖	Front and rear parking aid	109
㉗	Depending on equipment fitted:	
	– Gearshift lever (manual gearbox)	107
	– Selector lever (automatic gearbox)	115
㉘	Tyre pressure monitoring system	166
㉙	Depending on equipment fitted:	
	– Ashtrays	79
	– Storage compartment	84
㉚	Indicator light for a switched off front seat passenger airbag	152

Note

- Vehicles with a factory-fitted radio or radio navigation system are supplied with separate instructions for operating such equipment.
- The arrangement of the controls and switches and the location of some items on right-hand drive models may differ from that shown in ⇒ page 8, fig. 1. The symbols on the controls and switches are the same as for left-hand drive models. ■

Quick Reference Guide

Basic functions and important information

Introduction

The chapter of the quick reference guide is used as a quick reference of the most important operating elements of the vehicle. It is necessary to observe all the information which is contained in the following chapters of the Owner's Manual.

Unlocking and locking car

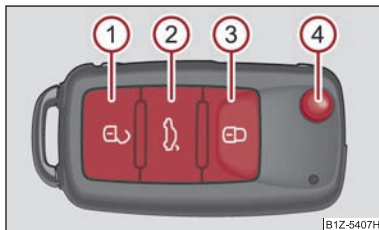

Fig. 2 Remote control key

- ① Unlocking the vehicle
- ② Unlocking the boot lid
- ③ Locking the vehicle
- ④ Folding out/folding up of the key

Further information ⇒ page 41, "Unlocking and locking car". ■

Setting steering wheel position

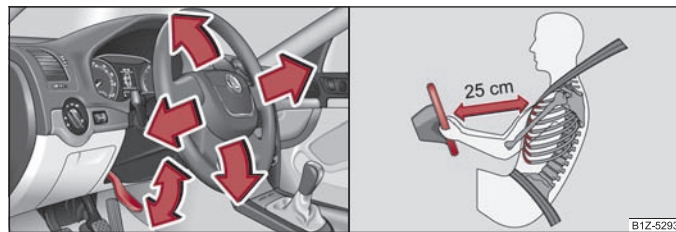

Fig. 3 Adjustable steering wheel: Lever on the steering column/the correct distance of the driver from the steering wheel

You can set the height and the forward/back position of the steering wheel to the desired position.

- Pull the lever below the steering wheel down ⇒ fig. 3 - left.
- Set the steering wheel to the desired position (concerning height and forward/back position).
- Push the lever upwards as far as the stop.

Further information ⇒ page 104, "Setting steering wheel position".

⚠ WARNING

- Adjust the steering wheel so that the distance between the steering wheel and your chest is at least 25 cm ⇒ fig. 3 - right. Not maintaining this minimum distance will mean that the airbag system will not be able to properly protect you - hazard!
- You must not adjust the steering wheel when the vehicle is moving!
- For safety reasons the lever must always be firmly pushed up to avoid the steering wheel altering its position unintentionally when driving - risk of accident! ■

Seat belt height adjuster

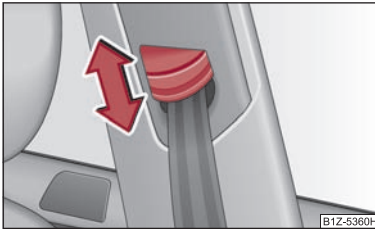

Fig. 4 Front seat: Seat belt height adjuster

- Press and move the height adjuster in the desired direction up or down ⇒ fig. 4.
- Then pull firmly on the belt to ensure that the seat belt height adjuster has correctly locked in place.

Further information ⇒ page 143, "Seat belt height adjuster on the front seats".

! WARNING

Adjust the height of the belt in such a way that the shoulder part of the belt is positioned approximately across the middle of your shoulder - on no account across your neck! ■

Adjusting the front seats



Fig. 5 Controls at seat

- 1 Adjusting a seat in a forward/back direction

- 2 Adjusting height of seat
- 3 Adjust the angle of the seat backrest
- 4 Adjusting lumbar support

Further information ⇒ page 64, "Adjusting the front seats".

! WARNING

Only adjust the driver seat when the vehicle is stationary - risk of injury! ■

Electric exterior mirror adjustment

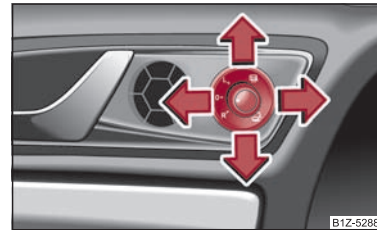

Fig. 6 Inner part of door: Rotary knob

	Heating of the external mirror
L	Adjusting left and right exterior mirrors simultaneously
R	Adjusting the right-hand exterior mirror
0	Switching off operating control
	Folding in both exterior mirrors

Further information ⇒ page 62, "Exterior mirror". ■

Switching lights on and off



B1Z-5193H

Fig. 7 Dash panel: Light switch

AUTO	Automatic light control
0	Switching off all lights/daylight driving lights
	Switching on side lights
	Switching on the low beam and main beam
	Fog lights
	Rear fog light

Further information ⇒ page 48, "Switching Switching lights on and off ". ■

Turn signal and main beam lever

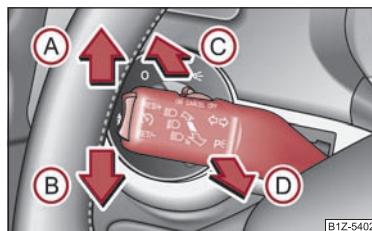

B1Z-5402H

Fig. 8 Turn signal and main beam lever

- (A) Turn signal light right
- (B) Turn signal light left
- (C) Switching over between low beam and main beam lights
- (D) Headlight flasher

Further information ⇒ page 54, "The turn signal and main beam lever ". ■

Windscreen wiper lever

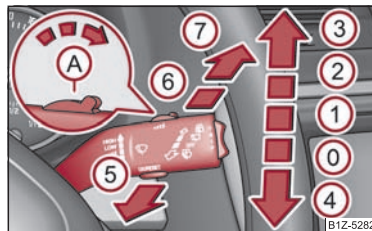

B1Z-5282H

Fig. 9 Windscreen wiper lever

- (A) Intermittent switch, sensitivity setting of the rain sensor
- (0) Wipers off
- (1) Intermittent wipe
- (2) Slow wipe

- ③ Fast wipe
- ④ one time wipe
- ⑤ Automatic wipe/wash

Rear window wiper

- ⑥ Intermittent wipe - every 6 seconds
- ⑦ Automatic wipe/wash

Further information ⇒ page 58, "Windshield wiper". ■

Power windows

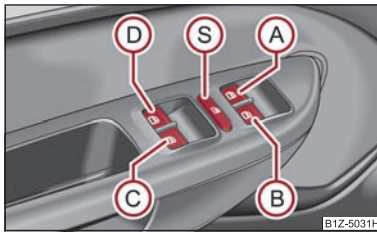

Fig. 10 Buttons on the driver's door

- Ⓐ Button for the power window in the driver's door
- Ⓑ Button for the power window in the front passenger's door
- Ⓒ Button for the power window at the rear right door
- Ⓓ Button for the power window at the rear left door
- Ⓢ Safety switch

Further information ⇒ page 43, "Power windows". ■

Refuelling

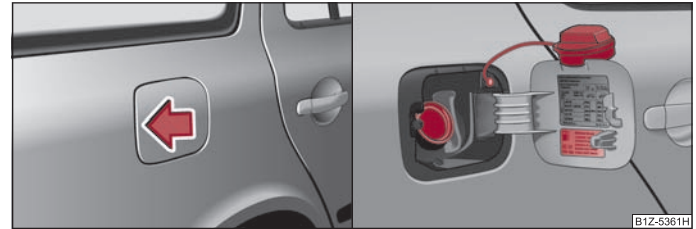

Fig. 11 Right rear side of the vehicle: Open fuel filler flap/fuel filler flap with cap unscrewed

The filler flap is automatically unlocked or locked with the central locking.

Opening the fuel filler cap

- Press in the middle of the left area of the fuel filler flap in direction of arrow ⇒ fig. 11 - left.
- Hold the fuel filler cap on the fuel filler tube with one hand and unlock it by turning the vehicle key to the left (only valid for vehicles which do not have automatic unlocking of the fuel filler flap).
- Unscrew the fuel filler cap anti-clockwise and place the fuel filler cap from above on the fuel filler flap ⇒ fig. 11 - right.

Closing fuel filler cap

- Screw on the cap by turning it to the right until it is heard to lock.
- Hold the fuel filler cap on the fuel filler tube with one hand and lock it by turning the vehicle key to the right (only valid for vehicles which do not have automatic locking of the fuel filler flap).
- Close the fuel filler flap until it locks.

Further information ⇒ page 185, "Refuelling". ■

Bonnet remote release

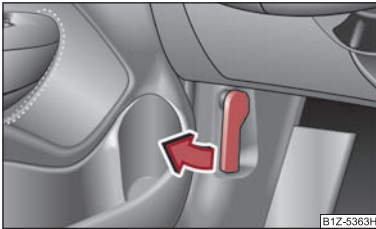

Fig. 12 Bonnet release lever

- Pull the unlocking lever below the dash panel on the driver's side ⇒ fig. 12. ■

Opening the bonnet

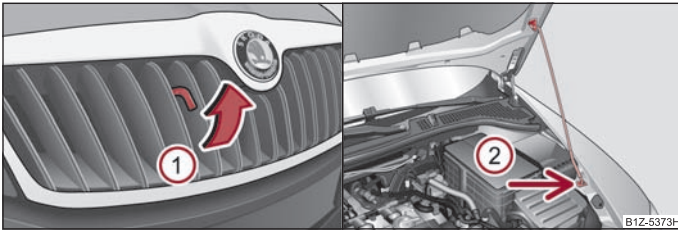

Fig. 13 Radiator grille: Locking lever/securing the bonnet with the bonnet support

- Pulling on the locking lever in direction of arrow ① ⇒ fig. 13 will unlock the bonnet.
- Take the bonnet support out of its holder and set it in the opening ②.

Further information ⇒ page 187, "Opening and closing the bonnet." ■

Inspecting the engine oil level

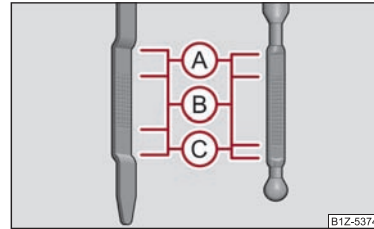

Fig. 14 Dipstick

- Ⓐ Engine oil **must not** be refilled.
- Ⓑ Engine oil **can** be refilled.
- Ⓒ Engine oil **must** be refilled.

Further information ⇒ page 189, "Check engine oil level". ■

Instruments and warning lights

Overview of the instrument cluster

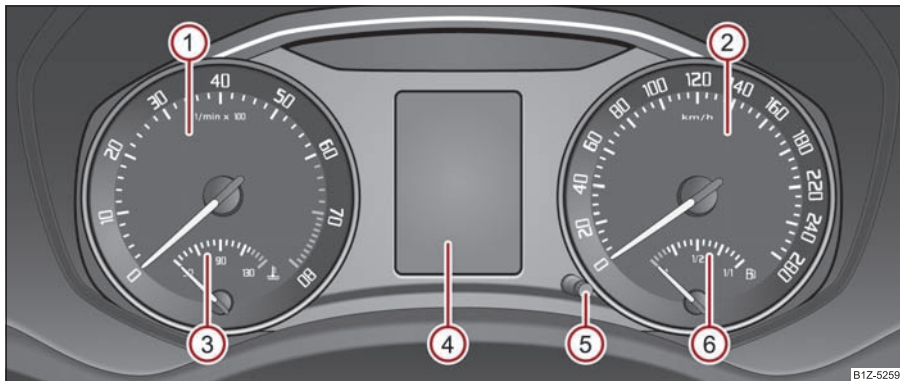

Fig. 15 Instrument cluster

- ① Engine revolutions counter ⇒ page 15
- ② Speedometer ⇒ page 16
- ③ Coolant temperature gauge ⇒ page 16
- ④ Display
 - with counter for distance driven ⇒ page 16
 - with Service Interval Display ⇒ page 17
 - with digital clock ⇒ page 18
 - with Multi-functional indicator ⇒ page 18
 - with Information display ⇒ page 22
- ⑤ Button for the selection of the mode (turn button)/the setting (press button):
 - Set hours/minutes
 - Activating/deactivating the second speed in mph or km/h
 - Service interval - Display of the remaining number of days, kilometres or miles to the next Inspection Service/Reset ¹⁾

- Reset trip counter for distance driven
- Resetting Service Interval Display
- Activate/deactivate display mode

- ⑥ Fuel gauge ⇒ page 16 ■

Engine revolutions counter

The red zone of the rev counter scale ① ⇒ fig. 15 indicates the range in which the engine control unit begins to limit the engine speed. The engine control unit restricts the engine speed to a steady limit value.

Shift into the next higher gear or select the selector lever position D of the automatic gearbox before reaching the red zone of the rev counter scale.

Avoid high engine speeds during the driving time and before the engine has been warmed up to operating temperature ⇒ page 168. ▶

¹⁾ Valid for countries where the values are indicated in British measuring units.



For the sake of the environment

Shifting to a higher gear in good time helps to reduce the fuel consumption, minimises operating noise levels, protects the environment and contributes to a longer life and reliability of the engine. ■

Speedometer

Warning against excessive speeds

An acoustic warning signal will sound when the vehicle speed exceeds 120 kilometres per hour. The acoustic warning signal will switch off again when the vehicle speed goes below this speed limit. ■

Coolant temperature gauge

The coolant temperature gauge  ⇒ page 15, fig. 15 operates only when the ignition is switched on.



Please pay attention to the following guidelines regarding temperature ranges in order to avoid damage to the engine:

Cold range

If the pointer is in the left-hand area of the scale it means that the engine has not yet reached its operating temperature. Avoid running at high engine speeds, at full throttle and at severe engine loads.

The operating range

The engine has reached its operating temperature as soon as the pointer moves into the mid-range of the scale. The pointer may also move further to the right at high engine loads and high outside temperatures. This is not critical provided the warning symbol  in the instrument cluster does not flash.

If the symbol  in the instrument cluster flashes it means that either the coolant temperature is too high or the coolant level is too low. Observe the guidelines ⇒ page 30, "Coolant temperature/ Coolant quantity ".



WARNING

Pay attention to the warning notes ⇒ page 188, "Working in the engine compartment" before opening the bonnet and inspecting the coolant level.



Caution

Additional headlights and other attached components in front of the fresh air inlet impair the cooling efficiency of the coolant. There is then a risk of the engine overheating at high outside temperatures and high engine loads! ■

Fuel gauge

The fuel gauge  ⇒ page 15, fig. 15 only operates when the ignition is switched on.

The fuel tank has a capacity of about 55 litres or 60 litres ²⁾. The warning symbol  in the instrument cluster lights up when the pointer reaches the reserve marking. There are now about 9 litres of fuel remaining in the tank. This symbol is a reminder for you, **that you must refuel.**

The following is displayed in the information display:

Please refuel! (Please refuel!)

An audible signal sounds as an additional warning signal.



Caution

Never run the fuel tank completely empty! An irregular supply of fuel can lead to irregular engine running. Unburnt fuel may get into the exhaust system and damage the catalytic converter.



Note

After filling up, it can occur that during dynamic driving (e.g. numerous curves, braking, driving downhill and climbing a steep hill) the fuel gauge indicates approx. a fraction less. When stopping or during less dynamic driving, the correct fuel supply quantity is indicated. This effect is not a fault. ■

Counter for distance driven

The distance which you have driven with your vehicle is shown in kilometres (km). In some countries the measuring unit "mile" is used. ▶

²⁾ Valid for Octavia Estate car 4x4 and Octavia Scout.

Reset button

If you hold the reset button (S) ⇒ page 15, fig. 15 pressed for about 1 second, the trip counter is set back to zero.

Trip counter for distance driven

The trip counter indicates the distance which you have driven since this counter was last reset - in steps of 100 metres or 1/10 of a mile.

Counter for distance driven

The counter for distance driven indicates the total distance in kilometers or miles which the vehicle has been driven.

Fault display

If there is a fault in the instrument cluster **Error** will appear continuously in the display. Have the fault rectified as soon as possible by a specialist workshop.

WARNING

Never seek to adjust the trip counter for distance driven while driving for safety reasons!

Note

If vehicles which are fitted with the information display the display of the second speed is activated in mph or km/h, this driving speed is indicated instead of the counter for the total distance driven. ■

Service reminder indicator



Fig. 16 Service Interval Display: Note

Depending on the equipment installed in the vehicle, the text can differ on the display.

Service Interval Display

Before the next service interval a key symbol  and the remaining kilometres are indicated after switching on the ignition ⇒ fig. 16. At the same time, a display appears regarding the remaining days until the next service interval.

The following is displayed in the information display:

Service after ... km or... days.

The kilometre indicator or the days indicator reduces in steps of 100 km. or days until the service due date is reached.

A flashing key symbol  and the text **Service** appears in the display for 20 seconds as soon as the due date for the service is reached.

The following is displayed in the information display:

Service now!

Display regarding the distance and days until the following service interval

You can use the button (S) to display the remaining distance driven and the days until the next service interval ⇒ page 15, fig. 15.

A key symbol  and a display regarding the remaining kilometers appear for 10 seconds in the display. At the same time, a display appears regarding the remaining days until the next service interval.

On vehicles which are equipped with an information display, you can call up this display in the menu **Settings** ⇒ page 24.

The following will be displayed in the information display for 10 seconds:

Service after ... km or... days.

Resetting Service Interval Display

It is only possible to reset the Service Interval Display, if a service message or at least a pre-warning is shown on the display of the instrument cluster.

We recommend having this resetting performed by a specialist garage.

The specialist garage:

- resets the memory of the display after the appropriate inspection,
- makes an entry in the Service schedule,
- affix the sticker with the entry of the following service interval to the side of the dash panel on the driver's side.

Reset the service interval displays by using the button (S) ⇒ page 15, fig. 15. ▶

On vehicles which are equipped with an information display, you can call up this display in the menu **Settings** ⇒ page 24.

⚠ Caution

We recommend that you do not reset the Service Interval Display yourself otherwise this can result in the service interval display being incorrectly set, which may also result in problems with operation of your vehicle.

ℹ Note

- Never reset the display between service intervals otherwise this may result in incorrect readouts.
- Information is retained in the Service Interval Display also after the battery of the vehicle is disconnected.
- If the instrument cluster is exchanged after a repair, the correct values must be entered in the counter for the Service Interval Display. This work is carried out by a specialist garage.
- The data displayed is the same after resetting the display with flexible service intervals (QG1) is displayed as that for a vehicle with fixed service intervals (QG2). We therefore recommend having the Service Interval Display reset only by an authorised Škoda Service Partner who is familiar with the procedure for resetting the display with a vehicle system tester.
- Please refer to the brochure Service schedule for extensive information about the service intervals. ■

Digital clock

You can set the time with the rotary knob (5) ⇒ page 15, fig. 15.

Select the information which you wish to change by turning the button (5) and carry out the change of the selected information by pressing the button.

On vehicles which are fitted with the information display, it is possible to set the time in the menu **Time** ⇒ page 24.

⚠ WARNING

The clock should not be adjusted while driving for safety reasons but only when the vehicle is stationary! ■

Shift recommendation for changing gears

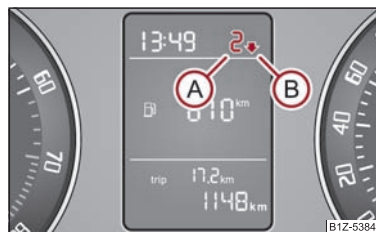

Fig. 17 Shift recommendation for changing gears

An information for the engaged gear (A) ⇒ fig. 17 is shown in the display of the instrument cluster.

In order to minimise the fuel consumption, a recommendation for shifting into another gear is indicated in the display.

If the control unit recognises that it is appropriate to change the gear, an arrow (B) is shown in the display. The arrow points up or down, depending on whether it is recommended to shift into a higher or lower gear.

At the same time, the recommended gear is indicated instead of the currently engaged gear (A). ■

Multi-functional indicator (onboard computer)

Introduction

The multi-functional indicator appears in the display ⇒ page 19, fig. 18 or in the information display ⇒ page 22 depending on the equipment fitted to your vehicle.

The multi-functional indicator offers you a range of useful information.

The outside temperature	⇒ page 20
Driving time	⇒ page 20
Current fuel consumption	⇒ page 20
Average fuel consumption	⇒ page 21

Range	⇒ page 21
Distance driven	⇒ page 21
Average speed	⇒ page 21
Current speed	⇒ page 21
oil temperature	⇒ page 21
Warning against excessive speeds	⇒ page 21

On vehicles which are fitted out with information display, it is possible to switch off the display of some information.

Note

- In certain national versions the displays appear in the Imperial system of measures.
- If the display of the second speed is activated in mph, the current speed is not indicated in km/h on the display. ■

Memory



Fig. 18 Multi-functional indicator

The multi-functional indicator is equipped with two automatic memories. The selected memory is displayed in the middle of the display field ⇒ fig. 18.

The data of the single-trip memory (memory 1) is shown if a **1** appears in the display. A **2** shown in the display means that data relates to the total distance memory (memory 2).

Switching over the memory with the help of the button **(B)** ⇒ fig. 19 on the windshield wiper lever or with the help of the button **(D)** on the ⇒ fig. 19 multifunction steering wheel.

Single-trip memory (memory 1)

The single-trip memory collates the driving information from the moment the ignition is switched on until it is switched off. New data will also flow into the calculation of the current driving information if the trip is continued **within 2 hours** after switching off the ignition. If the trip is interrupted for **more than 2 hours**, the memory is automatically erased.

Total-trip memory (memory 2)

The total distance driven memory gathers data from any number of individual journeys up to a total of 19 hours and 59 minutes driving or 1 999 kilometres driven. 99 hours and 59 minutes driving time or 9 999 km driven in vehicles with an Information display. The memory is deleted when either of these limits is reached and the calculation starts from anew.

The total-trip memory will not, contrary to the single-trip memory, be deleted after a period of interruption of driving of 2 hours.

Note

All information in the memory 1 and 2 is erased if the battery of the vehicle is disconnected. ■

Operating with the buttons on the windshield wiper lever and on the multifunction steering wheel

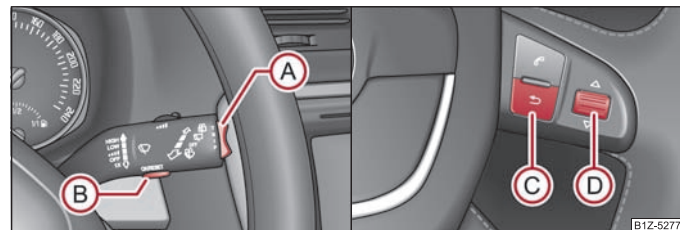

Fig. 19 Multi-functional indicator: Controls on the windshield wiper lever/controls on the multifunction steering wheel

The rocker switch **(A)** and the button **(B)** are located on the windshield wiper lever ⇒ page 19, fig. 19. Switching over and resetting is performed with the handwheel **(D)** on the multifunction steering wheel.

Selecting the memory

- After briefly pressing the button **(B)** on the windshield wiper lever or by briefly pressing the button **(D)** on the multifunction steering wheel, you can select the desired memory.

Selecting the functions with the help of the windshield wiper lever

- Press the top or bottom rocker switch **(A)** for longer than 0.5 seconds. In this way, call up in sequence the individual functions of the multi-functional indicator.

Selecting the functions with the help of the multifunction steering wheel

- By pressing the button **(C)**, you can call up the menu of the multi-functional indicator.
- Turn the handwheel **(D)** upwards or downwards. In this way, call up in sequence the individual functions of the multi-functional indicator.

Setting function to zero

- Select the memory you want.
- Press the button **(B)** or **(D)** for more than 1 second.

The following readouts of the selected memory will be set to zero with the button **(B)** on the windshield wiper lever or with the button **(D)** on the multifunction steering wheel:

- average fuel consumption,
- distance driven,
- average speed,
- Driving time.

You can only operate the multi-functional indicator when the ignition is switched on. After the ignition is switched on, the function displayed is the one which you last selected before switching off the ignition. ■

Outside temperature

The outside temperature appears in the display when the ignition is switched on.

If the outside temperature drops below +4 °C, a snow flake symbol (warning signal for ice on the road) appears before the temperature indicator and a warning signal sounds. After pressing the rocker switch **(A)** at the windshield wiper lever ⇒ page 19, fig. 19 or the button **(C)** at the multifunction steering wheel ⇒ page 19, fig. 19, the function shown last is indicated.



WARNING

Do not only rely upon the information given on the outside temperature display that there is no ice on the road. Please note that black ice may also be present on the road surface even at temperatures around +4 °C - warning, drive with care! ■

Driving time

The driving time which has elapsed since the memory was last erased, appears in the display. If you wish to measure the driving time as of a particular time, you must set the memory to zero at this moment in time by pressing the button **(B)** on the windshield wiper lever ⇒ page 19, fig. 19 or the handwheel **(D)** on the ⇒ page 19, fig. 19 multifunction steering wheel for longer than 1 second.

The maximum distance indicated in both memories is 19 hours and 59 minutes. 99 hours and 59 minutes in vehicles with an Information display. The indicator is set back to null if this period is exceeded. ■

Current consumption

The current fuel consumption level is shown in the display in litres/100 km. This information can help you to adapt your style of driving to the fuel consumption you wish to achieve.

The display appears in litres/hour if the vehicle is stationary or driving at a low speed.

The indicated value will be updated every 0.5 seconds while you are driving. ■

Average fuel consumption

The average fuel consumption since the memory was last erased is shown in the display in litres/100 km ⇒ page 19. This information can help you to adapt your style of driving to the fuel consumption you wish to achieve.

If you wish to determine the average fuel consumption over a certain period of time you must set the memory to zero at the start of the measurement using the button **(B)** on the windshield wiper lever ⇒ page 19, fig. 19 or with the handwheel **(D)** on the multifunction steering wheel ⇒ page 19, fig. 19. A zero appears in the display for the first 100 m you drive after erasing the memory.

The indicated value will be updated every 5 seconds while you are driving.



Note

The amount of fuel consumed will not be indicated. ■

Range

The estimated range in kilometres is shown on the display. It indicates the distance you can still drive with your vehicle based on the present level of fuel in the tank for the same style of driving.

The readout is shown in steps of 10 km. After lighting up of the indicator light for the fuel reserve the display is shown in steps of 5 km.

The fuel consumption for the last 50 km is taken as a basis for calculating the range. If you drive in a more economical manner from this moment on, the range will be increased accordingly.

If the memory is set to zero (after disconnecting the battery), the fuel consumption of 10 ltr./100 km is calculated for the range; afterwards the value is adapted accordingly to the style of driving. ■

Distance driven

The distance driven since the memory was last erased appears in the display ⇒ page 19. If you wish to measure the distance driven of a particular time, you must set the memory to zero at this moment in time by pressing the button **(B)** on the windshield wiper lever ⇒ page 19, fig. 19 or the handwheel **(D)** on the multifunction steering wheel ⇒ page 19, fig. 19.

The maximum distance indicated in both memories is 1 999 km or on vehicles with information display, it is 9 999 km. The indicator is set back to null if this period is exceeded. ■

Average speed

The average speed since the memory was last erased is shown in the display in km/hour ⇒ page 19. If you wish to determine the average vehicle speed over a certain period of time you must set the memory to zero at the start of the measurement using the button **(B)** on the windshield wiper lever ⇒ page 19, fig. 19 or with the handwheel **(D)** on the multifunction steering wheel ⇒ page 19, fig. 19.

A zero appears in the display for the first approx. 300 m you drive after erasing the memory.

The indicated value will be updated every 5 seconds while you are driving. ■

Current speed

The current speed which is identical to the display of the speedometer, is indicated on the display **(2)** ⇒ page 15, fig. 15. ■

oil temperature

If the oil temperature is lower than 50 °C or if a fault in the system for checking the oil temperature is present, three lines are displayed instead of the oil temperature. ■

Warning against excessive speeds

Adjust the speed limit while the vehicle is stationary

- With the **(A)** button on the multi-function steering wheel ⇒ page 19, fig. 19 or the handwheel **(D)** on the multi-function steering wheel ⇒ page 19, fig. 19, choose the menu point **Warning against excessive speeds**.
- Choose the **(B)** button on the multi-function steering wheel, or the handwheel **(D)** on the multi-function steering wheel, to activate the option for setting the speed limit (the value flashes).
- Use the **(A)** button on the windshield wiper lever or the handwheel **(D)** on the multi-function steering wheel to set the required speed limit., e.g. 50 km/h.
- Use the **(B)** button on the windshield wiper lever or the handwheel **(D)** on the multi-function steering wheel to confirm the required speed limit, or wait around 5 seconds. The setting saves automatically (the value stops flashing).

This allows you to set the speed in 5 km/h intervals. ►

Adjust the speed limit while the vehicle is moving

- With the **(A)** button on the multi-function windshield wiper lever or the hand-wheel **(D)** on the multi-function steering wheel, choose the menu point **Warning against excessive speeds**.
- You can drive at the desired speed, e.g. 50 km/h
- Use the **(B)** button on the multi-function steering wheel, or the handwheel **(D)** on the multi-function steering wheel to accept the current speed as the speed limit (the value flashes).

If you wish to change the speed limit that was set, it is changed in 5 km/h intervals (e.g. the accepted speed of 47 km/h increases to 50 km/h or decreases to 45 km/h).

- Press the **(B)** button on the windshield wiper lever a second time or the hand-wheel **(D)** on the multi-function steering wheel to confirm the required speed limit, or wait around 5 seconds. The setting saves automatically (the value stops flashing).

Change or delete speed limit

- With the **(A)** button on the multi-function windshield wiper lever or the hand-wheel **(D)** on the multi-function steering wheel, choose the menu point **Warning against excessive speeds**.
- Press the button **(B)** on the windshield wiper lever or the handwheel **(D)** on the multifunction steering wheel to delete the speed limit.
- Press the button **(B)** on the windshield wiper lever a second time or the hand-wheel **(D)** on the multifunction steering wheel to activate the speed limit.

If you exceed the set speed limit, an acoustic warning signal will sound as a warning. At the same time the message **Warning against excessive speeds** appears with the set limit value.

The set speed limit remains stored even after switching off the ignition.

MAXI DOT display (information display)

Introduction

The information display provides you with information in a convenient way concerning the **current operating state of your vehicle**. The information system also provides you with data (depending on the equipment installed in the vehicle) relating to the radio, mobile phone, multi-functional indicator, radio navigation system, the unit connected to the MDI input and the automatic gearbox.

Certain functions and operating conditions are always being checked on the vehicle when the ignition is switched on and also while driving.

Functional faults, if required repair work and other information are indicated by red symbols ⇒ page 24 and yellow symbols ⇒ page 24.

Lighting up of certain symbols is combined with an acoustic warning signal.

Information and texts giving warnings are also shown in the display ⇒ page 26.

The following information can be shown in the display (depending on the equipment installed on the vehicle):

Main menu	⇒ page 23
Door, luggage compartment door and bonnet ajar warning	⇒ page 23
Service Interval Display	⇒ page 17
Selector lever position for an automatic gearbox	⇒ page 114



WARNING

Pay attention primarily to the traffic situation! As the driver you are fully responsible for road safety. ■

Main menu

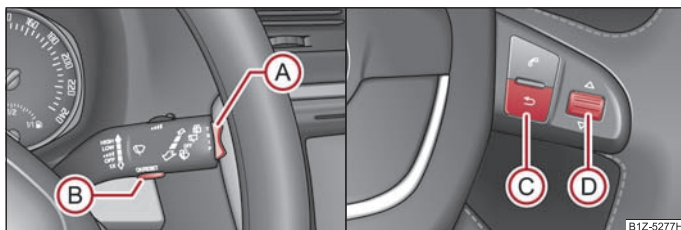

Fig. 20 Information display: Controls on the windshield wiper lever/controls on the multifunction steering wheel

Operating with the buttons on the windshield wiper lever

- You can activate the **Main Menu** by pressing the rocker switch **A** ⇒ fig. 20 for more than 1 second.
- You can select individual menu points by means of the rocker switch **A**. When the pushbutton **B** is briefly pressed, the information you have selected is displayed.

Operating with the buttons on the multifunction steering wheel

- You can activate the **Main menu** by pressing the rocker switch **C** ⇒ fig. 20 for more than 1 second.
- By briefly pressing the **C** button you will reach one level higher.
- You can select the individual menus by pressing the handwheel **D**. After briefly pressing the handwheel **D**, the desired menu is indicated.

You can select the following information (depending on the equipment installed on the vehicle):

- **MFD (MFA)** ⇒ page 18
- **Audio**
- **Navigation**
- **Phone** ⇒ page 122
- **Aux. Heating (auxiliary heating)** ⇒ page 100
- **Assistants** ⇒ page 50

- **Vehicle status** ⇒ page 24
- **Settings** ⇒ page 24

The menu point **Audio** is only then displayed when the factory-fitted car radio is switched on.

The menu point **Navigation** is only then displayed when the factory-fitted radio navigation system is switched on.

The menu point **Aux. heating** is only then displayed, if the vehicle is factory-fitted with auxiliary heating.

The menu point **Assistants** is only then displayed, if the vehicle is fitted with cornering lights.

Note

- If warning messages are shown in the information display, these messages can be confirmed with the button **B** on the windshield wiper lever or with the button **D** on the multifunction steering wheel in order to call up the main menu.
- If you do not activate the information display at that moment, the menu shifts to one level higher every 10 seconds.
- The operation of the factory-fitted car radio or radio navigation system is described in separate operating instructions to be found in the on-board literature. ■

Door, luggage compartment door and bonnet ajar warning

The door, luggage compartment and bonnet ajar warning lights up if at least one door, the luggage compartment or bonnet are not closed. The symbol indicates which door is still open or whether the luggage compartment door or bonnet is **not closed**.

The symbol goes out as soon as the doors, luggage compartment door and bonnet are completely closed.

A warning signal sounds if the car is driven at a speed of more than 6km/hour and if the engine or the luggage compartment door is open. ■

Auto Check Control

Car state

The Auto Check Control carries out a check of certain functions and vehicle components. The check is performed constantly when the ignition is switched on, both when the vehicle is stationary, as well as when driving.

Some operational faults, urgent repairs, service work or other information appear in the display of the instrument cluster. The displays are shown with a red or yellow light symbol depending on the priority of the message.

The red symbols indicate **danger** (priority 1) while the yellow symbols indicate a **warning** (priority 2). Information for the driver may also appear in addition to the symbols → page 26.

There is at least one error message when the term **Vehicle status** is displayed in the menu. After selecting this menu the first of the error messages is displayed. Several error messages are shown on the display under the message e.g. **1/3**. This indicates that the first of a total of three error messages is displayed. Investigate the displayed faults as soon as possible.

As long as the operational faults are not rectified, the symbols are always indicated again. After the first display, the symbols are indicated without information for the driver.

If a fault occurs, a warning signal will also sound in addition to the symbol and text in the display:



- Priority 1 - three warning signals
- Priority 2 - one warning signal ■

Red symbols

A red symbol signals danger.

- Bring the vehicle to a stop.
- Switch the engine off.
- Investigate the function indicated.
- Obtain professional assistance.

Meaning of the red symbols:

	Engine oil pressure too low	⇒ page 29
	Overheated clutches of the automatic gearbox DSG	⇒ page 34



Three successive warning signals will sound if a red symbol appears. ■

Yellow symbols

A yellow symbol signals a warning.

Check the relevant function as soon as possible.

The meaning of the yellow symbols:

	Check engine oil level, engine oil sensor faulty	⇒ page 34
	Problem with engine oil pressure	It is also important to have the vehicle inspected without delay by a specialist garage. The information about the maximum permissible engine speed is displayed together with this symbol.

In certain countries, if a yellow symbol appears **one** warning signal will sound as well.

If several operational faults of priority 2 exist, the symbols appear one after the other and are each illuminated for about 5 seconds. ■

Set-up

You can change certain settings by means of the information display. The current setting is shown on the information display in the respective menu at the top below the line.

You can select the following information (depending on the equipment installed on the vehicle):

- Language
- MFD Data
- Convenience
- Lights & Vision
- Time

- Winter tyres
- Units
- Assistants
- Alternative speed displayed (Second speed)
- Service Interval (Service)
- Factory setting
- Back

After selecting the menu point **Back** you will reach one level higher in the menu.

Language

Here you can set in which language the warning and information texts should be displayed.

Displays of the MFA

Here you can switch off or on certain displays of the multi-functional indicator.

Comfort

Here you can activate, deactivate or adjust the following functions:

Rain closing	Switch on/off the function for automatically closing the window and panoramic tilt/slide sunroof in a locked rain when it starts raining ^{a)} . If the function is set and it is not raining, the windows including the panoramic tilt/slide sunroof will close automatically after approx. 12 hours.
ATA confirm	Switch on/off the acoustic signal indicating activation of the anti-theft alarm system.
Central locking	Switch on/off the central locking and automatic locking function.
Window op.	Here you can set the convenience mode only for the driver window or for all the windows.
Mirror down	Switch on/off the function for mirror lowering on the front passenger side when engaging the reverse gear ^{b)} .
Mirror adjust.	Switch on/off the function for left and right exterior mirror setting simultaneously.
Factory setting	Restore the Convenience factory setting.

^{a)} This function is only available on vehicles with a rain sensor.

^{b)} This function is only available on vehicles with an electrically adjustable driver seat.

Lights and Visibility

Here you can activate, deactivate or adjust the following functions:

Coming Home	Switch on/off and adjust the light duration of the Coming Home function.
Leaving Home	Switch on/off and adjust the light duration of the Leaving Home function.
Dayl. dri. light	Switch on/off the "DAY LIGHT" function.
Lane ch. flash (convenience flashing)	Switch on/off the convenience flashing function.
Rear wiper	Switch on/off the function for automatic rear window wiping.
Travel mode	Switch on/off the travel model function.
Factory setting	Restore the factory setting for the lighting.

Time

Here you can set the time, the time format (12 or 24 hour indicator) and the time change summer/winter time.

Winter tyres

Here you can set at which speed a warning signal should sound. This function is used for e.g winter tyres with the permissible maximum speed less than the maximum speed of the vehicle.

When exceeding the speed, an indication is displayed on the information display:

Winter tyres max. speed ... km/h

Measures

Here you can set the units for temperature, consumption and distance driven.

Assistant

Here you can adjust the tones of the acoustic signals of the parking aid. ▶

Second speed

Here you can switch on the display of the second speed in mph or in km/h³⁾.

³⁾ Valid for countries where the values are indicated in British measuring units.

Service

Here you can have the kilometers still to be driven and the days until the following service interval shown and the Service Interval Display reset.

Factory Setting

After selecting the menu **Factory Setting** the factory setting of the information display is established again. ■



Warning lights



Overview



















The warning lights indicate certain functions or faults.











Fig. 21 Instrument cluster with warning lights

	Turn signal lights (to the left)	⇒ page 28
	Turn signal lights (to the right)	⇒ page 28
	Fog lights	⇒ page 28

	Main beam	⇒ page 28
	Low beam	⇒ page 28
	Rear fog light	⇒ page 28

	Speed regulating system	⇒ page 28
	Failure of the light bulbs	⇒ page 28
	Diesel particle filter (diesel engine)	⇒ page 28
	Airbag system	⇒ page 29
	Control system for exhaust	⇒ page 29
	Electromechanical power steering	⇒ page 29
	Engine oil pressure	⇒ page 29
	EPC fault light (petrol engine)	⇒ page 30
	Glow plug system (diesel engine)	⇒ page 30
	Coolant temperature/coolant level	⇒ page 30
	Traction control system (TCS)	⇒ page 31
	Electronic stability programme (ESP)	⇒ page 31
	Switch off traction control system (TCS)	⇒ page 31
	Selector lever lock	⇒ page 31
	Tyre pressure	⇒ page 31
	Antilock brake system (ABS)	⇒ page 32
	Bonnet	⇒ page 32
	Seat belt warning light	⇒ page 32

	Boot lid	⇒ page 32
	Open door	⇒ page 33
	Fluid level in windshield washer system	⇒ page 33
	Brake system	⇒ page 33
	Handbrake	⇒ page 33
	Dynamo	⇒ page 33
	Engine oil level	⇒ page 34
	Fuel reserve	⇒ page 34



WARNING

- If you do not pay attention to the warning lights coming on and the corresponding descriptions and warning notes, this may result in severe body injuries or major vehicle damage.
- The engine compartment of your car is a hazardous area. There is a risk of injuries, scalding, accidents and fire when working in the engine compartment, e.g. inspecting and replenishing oil and other fluids. It is also essential to observe all warnings ⇒ page 188, "Working in the engine compartment".

Note

- The arrangement of the indicator lights depends on the model version. The symbols shown in the following functional description are to be found as indicator lights in the instrument cluster.
- Operational faults are shown in the instrument cluster as red symbols (priority 1 - danger) or yellow symbols (priority 2 - warning). ■

Turn signal system

Either the left  or right  indicator light flashes depending on the position of the turn signal lever.

The indicator light flashes at twice its normal rate if a turn signal light fails. This does not apply when towing a trailer.

Switching off the hazard warning light system is switched on will cause all of the turn signal lights as well as both indicator lights to flash.

Further information about the turn signal system ⇒ page 54. ■

Fog lights

The warning light  comes on when the fog lights are operating ⇒ page 51. ■

Main beam

The indicator light  comes on when the main beam is selected or also when the headlight flasher is operated.

Further information about the main beam ⇒ page 54. ■

Low beam

The indicator light  comes on when low beam is selected ⇒ page 48. ■

Rear fog light

The warning light  comes on when the rear fog lights are operating ⇒ page 52. ■

Cruise control system

The warning light  lights up, when operating the speed regulating system. ■

Bulb failure

The warning light  comes on if a bulb is faulty:

- up to 2 seconds after the ignition is switched on,

- when switching on the defective light bulb.

The following text e.g will be displayed in the information display:

Check front right dipped beam! ■



Diesel particle filter (diesel engine)

If the warning light  comes on, this means that soot has accumulated in the diesel particle filter because of the frequent short distances.

In order to clean the diesel particle filter, the vehicle should be driven at an even speed of at least 60 km/h at engine speeds of 1 800 - 2 500 rpm for at least 15 minutes or until the warning light goes out with the 4th or 5th gear engaged (automatic gearbox: position S) when the traffic situation permits it. This increases the exhaust temperature and the soot deposited in the diesel particle filter is burnt.

Always pay attention to the valid speed limits ⇒ .

The warning light  goes out after the successful cleaning of the diesel particle filter.

If the filter is not properly cleaned, the warning light  does not go out and the warning light  begins to flash. The following is displayed in the information display: **Diesel-particle filter: Owner's manual!** appears. Afterwards the engine control unit shifts the engine into the emergency mode, which only has a reduced power output. After switching the ignition off and on again the warning light  comes on.

Have the vehicle inspected without delay by your specialist garage.

WARNING

- If you do not pay attention to the warning light coming on and the corresponding descriptions and warning notes, this may result in injuries or major vehicle damage.
- Always adjust your speed to suit weather, road, region and traffic conditions. The route indicated by the warning light must not tempt you to disregard the national regulations for road traffic.

Caution

As long as the warning light  lights up, one must take into account an increased fuel consumption and in certain circumstances a power reduction of the engine. ▶

Note

Further information about diesel particle filter ⇒ page 167. ■

Airbag system **Monitoring the airbag system**

The warning light  comes on for a few seconds when the ignition is switched on.

There is a fault in the system if the warning light does not go out or flashes while driving ⇒ . This also applies if the warning light does not come on when the ignition is switched on.

The following text will be displayed in the information display:

Error: Airbag

The functionality of the airbag system is also monitored electronically when one airbag has been switched off.

The following situation applies if the front, side and head airbags or belt tensioner have been switched off using the vehicle system tester:

- The warning light  lights up for 4 seconds after switching on the ignition and then flashes again for 12 seconds in intervals of 2 seconds.

The following text will be displayed in the information display:

Airbag/belt tensioner deactivated

The following situation applies if the airbag has been switched off using the switch for the airbag in the front passenger storage compartment:

- the warning light  comes on for 4 seconds after the ignition has been switched on,
- switching off the airbag is indicated in the middle of the dash panel by the lighting up of the indicator light **AIRBAG OFF (airbag switched off)** ⇒ page 152.

WARNING

Have the airbag system checked immediately by a specialist garage if a fault exists. Otherwise, there is a risk of the airbag not being activated in the event of an accident. ■



Control system for exhaust 

The warning light  comes on after the ignition has been switched on.

If the warning light does not go out after starting the engine or it lights up when driving, a fault exists in an exhaust relevant component. The engine management system selects an emergency programme which enables you to drive to the nearest specialist garage by adopting a gentle style of driving. ■

Electromechanical power steering  

The warning light  comes on for a few seconds when the ignition is switched on. If the warning light after switching on the ignition or when driving lights up continuously, a fault exists in the electromechanical power steering.



- If the **yellow** warning light lights up , this indicates a partial failure of the power steering and the steering forces can be greater.
- If the **red** warning light lights up , this indicates a complete failure of the power steering and the steering assist has failed (significantly higher steering forces).

Further information ⇒ page 165.

WARNING

Contact your specialist garage if the power steering is defective.

Note

- If the yellow warning light  goes out after starting the engine again and a short drive, it is not necessary to visit a specialist garage.
- If the battery has been disconnected and reconnected, the yellow warning light  comes on after switching on the ignition. The warning light must go out after driving a short distance. ■

Engine oil pressure 

The warning light  comes on for a few seconds ⁴⁾ when the ignition is switched on.

Stop the vehicle and switch the engine off if the warning light does not go off after the engine has started or flashes while driving. Check the oil level and top up with oil as necessary ⇒ page 190, "Replenishing engine oil". ▶

⁴⁾ The warning light  on vehicles fitted with information display does not come on after switching the ignition on, but only if a fault exists or the engine oil level is too low.

An audible signal sounds three times as an additional warning signal.

Do not continue your journey if for some reason it is not possible under the conditions prevailing to top up with oil. **Keep the engine switched off** and obtain professional assistance from a specialist garage, otherwise it could lead to severe engine damage.

Do not drive any further if the warning light flashes even if the oil is at the correct level. Do not run the engine not at idling speed either. Contact the nearest specialist garage to obtain professional assistance.

The following text will be displayed in the information display:

Oil Pressure: Engine off! Owner's manual Switch off the engine! Car documentation!

WARNING



- If you must stop for technical reasons, then park the vehicle at a safe distance from the traffic and switch off the engine and switch on the hazard warning light system.
- The red oil pressure light  is not an oil level indicator! One should therefore check the oil level at regular intervals, preferably after every refueling stop. ■

EPC fault light (petrol engine)

The **EPC** (Electronic Power Control) warning light comes on for a few seconds when the ignition is switched on.

If the warning light **EPC** does not go out or lights up after starting the engine, a fault exists in the engine control. The engine management system selects an emergency programme which enables you to drive to the nearest specialist garage by adopting a gentle style of driving. ■

Glow plug system (diesel engine)

The warning light  lights up for a cold engine when switching on the ignition (pre-heat position)  ⇒ page 104. Start the engine after the indicator light goes out.

The glow plug indicator light will come on for about 1 second if the engine is at a normal operating temperature or if the outside temperature is above +5 °C. This means that you can start the engine **right away**.

There is a fault in the glow plug system if the **warning light  does not come on or lights up continuously**; contact a specialist garage as soon as possible to obtain assistance.

If the **warning light  begins to flash** while driving, a fault exists in the engine control. The engine management system selects an emergency programme which enables you to drive to the nearest specialist garage by adopting a gentle style of driving. ■

Coolant temperature/ Coolant quantity

The warning light  comes on for a few seconds ⁵⁾ when the ignition is switched on.

The coolant temperature is too high or the coolant level too low if the warning light  does not go out or flashes while driving.

3 beeps sound as an additional warning signal.

In this case stop and switch the engine off and check the coolant level; top up the coolant as necessary.

Do not continue your journey if for some reason it is not possible under the conditions prevailing to top up with coolant. **Keep the engine switched off** and obtain professional assistance from a specialist garage, otherwise it could lead to severe engine damage.

If the coolant is within the specified range, the increased temperature may be caused by an operating problem at the coolant fan. Check the fuse for the coolant fan, replace it if necessary ⇒ page 218, "Fuse assignment in engine compartment".

Do not continue driving if the warning light does not go off although the fluid is at the correct level and also the fuse of the fan is in proper order. Contact a specialist garage to obtain assistance.

Please refer to the following guidelines ⇒ page 191, "Cooling system".

The following text will be displayed in the information display:

Check coolant! Owner's manual! Check coolant! Car documentation!

WARNING

- If you must stop for technical reasons, then park the vehicle at a safe distance from the traffic and switch off the engine and switch on the hazard warning light system ⇒ page 53. ▶

⁵⁾ The warning light  on vehicles fitted with information display does not come on after switching the ignition on, but only if the coolant temperature is too high or the coolant level is too low.

⚠ WARNING (continued)

- Take care when opening the coolant expansion bottle. If the engine is hot, the cooling system is pressurized - risk of scalding! It is best to allow the engine to cool down before removing the cap.
- Do not touch the coolant fan The coolant fan may switch on automatically even if the ignition is off. ■

Traction control system (TCS) 

The warning light  comes on for a few seconds when the ignition is switched on.

The warning light comes on when driving when a control cycle is activated.

The warning light lights up permanently if there is a fault in the TCS system.

The fact that the TCS system operates together with the ABS means that the TCS warning light will also come on if the ABS system is not operating properly.

If the warning light  comes on immediately after starting the engine, the TCS system can be switched off for technical reasons. In this case, the TCS system can be switched on again by switching the ignition on and off. If the warning light goes out, the TCS system is fully functional again.

Further information about the TCS ⇒ page 162, "Traction control system (TCS)".

 Note

If the battery has been disconnected and reconnected, the warning light  comes on after switching on the ignition. The warning light must go out after driving a short distance. ■

Switch off the Traction control system (TCS) 

The TCS system is switched off by pressing the button ⇒ page 162, fig. 152 and the warning light  lights up. ■

Electronic stability programme (ESP) 

The warning light  comes on for a few seconds when the ignition is switched on.

When the ESP helps to stabilise the vehicle, the warning light  flashes in the instrument cluster.

The warning light lights up permanently if there is a fault in the ESP system.

The fact that the ESP system operates together with the ABS means that the ESP warning light will also come on if the ABS system is not operating properly.

If the warning light  comes on immediately after starting the engine, the ESP system can be switched off for technical reasons. In this case, the ESP system can be switched on again by switching the ignition on and off. If the warning light goes out, the ESP system is fully functional again.

Further information on the ESP ⇒ page 161, "Electronic stability programme (ESP)".

Electronic Differential Lock (EDL)

The EDL is a part of the ESP. A fault in the EDL is indicated by the lighting up of the ESP warning light in the instrument cluster. Have the vehicle inspected immediately by your specialist garage. Further information on the EDL ⇒ page 162, "Electronic Differential Lock (EDL and XDL)".

 Note

If the battery has been disconnected and reconnected, the warning light  comes on after switching on the ignition. The warning light must go out after driving a short distance. ■

Selector lever lock 

If the **green** warning light  lights up, operate the brake pedal. This is necessary, in order to be able to move the selector lever out of the position **P** or **N**.

Further information about the selector lever lock ⇒ page 116. ■

Tyre inflation pressure 

The warning light  lights up, if there is a substantial drop in inflation pressure in one of the tyres. Reduce the speed and check or correct as soon as possible the inflation pressure in the tyres ⇒ page 199.

If the warning light flashes, there is a system fault. Visit the nearest specialist garage and have the fault rectified.

Further information about the tyre pressure monitoring system ⇒ page 166.

⚠ WARNING

- When the warning light  lights up, immediately reduce the speed and avoid sudden steering and brake manoeuvres. Please stop the vehicle without

⚠ WARNING (continued)

delay at the nearest possible stop and inspect the tyres and their inflation pressures.

- Under certain circumstances (e.g. sporty style of driving, wintry or unpaved roads) the warning light  can be delayed or does not light up at all.

 Note

If the battery has been disconnected, the warning light  comes on after switching on the ignition. The warning light must go out after driving a short distance. ■

Antilock brake system (ABS) 

The warning light  shows the functionality of the ABS.



The warning light comes on for a few seconds after the ignition has been switched on or when starting the engine. The warning light goes out after an automatic check sequence has been completed.

A fault in the ABS



The system is not functioning properly if the ABS warning light  does not go out within a few seconds after switching on the ignition, does not light up at all or lights up while driving. The vehicle will only be braked by the normal brake system. Visit a specialist garage immediately and adjust your style of driving appropriately as you will not know how great the damage is.

Further information about ABS ⇒ page 164, "Antilock brake system (ABS)".

A fault in the entire brake system

If the ABS warning light  comes on together with the brake system warning light , (handbrake must be released), there is a fault not only in the ABS but also in another part of the brake system ⇒ .



 WARNING

- If the brake system warning light  comes on together with the ABS warning light  stop the vehicle immediately and check the brake fluid level in the reservoir ⇒ page 193, "Brake fluid". If the fluid level has dropped below the MIN marking, do not drive any further - risk of accident! Contact a Škoda dealer to obtain professional assistance.

 WARNING (continued)

- Pay attention to the following instructions ⇒ page 188, "Working in the engine compartment" before checking the brake fluid level and opening the bonnet.
- If the brake fluid is at the correct level, the ABS control function has failed. The rear wheels may then block very rapidly when braking. In certain circumstances, this can result in the rear end of the car breaking away - risk of skidding! Drive carefully to the nearest specialist garage and have the fault rectified. ■

Bonnet 

The warning light  comes on if the bonnet is unlocked. If the engine bonnet unlocks while driving , the warning light lights up and an audible signal sounds.

The warning light comes on even when the ignition is switched off. The warning light lights up for a maximum of 5 minutes.

On vehicles with an Information display this warning light is replaced by a vehicle symbol ⇒ page 23. ■

Seat belt warning light 



The warning light  comes on after the ignition is switched on as a reminder for the driver to fasten the seat belt. The warning light only goes out if the driver has fastened his seat belt.

If the seat belt has not been fastened by the driver, a permanent warning signal sounds at vehicle speeds greater than 20 km/h and simultaneously the warning light  flashes.

If the seat belt is not fastened by the driver during the next 90 seconds, the warning signal is deactivated and the warning light  lights up permanently.

Further information on the seat belts ⇒ page 141, "Seat belts". ■

Boot lid 

The warning light  comes on when the ignition is switched on if the luggage compartment door is open. If the boot lid opens while driving , the warning light lights up and an audible signal sounds.

An audible signal sounds as an additional warning signal. ►

The warning light comes on even when the ignition is switched off. The warning light lights up for a maximum of 5 minutes.

On vehicles with an Information display this warning light is replaced by a vehicle symbol ⇒ page 23. ■

Open door

The warning light  comes on, if one or several doors are opened. If one of the doors opens while driving, the warning light lights up and an audible signal sounds.

The warning light comes on even when the ignition is switched off. The warning light lights up for a maximum of 5 minutes.

On vehicles with an Information display this warning light is replaced by a vehicle symbol ⇒ page 23. ■

Windshield washer fluid level



The warning light  comes on when the ignition is switched on if there is insufficient fluid in the windshield washer system. Top up with liquid ⇒ page 197.

The following text will be displayed in the information display:

Top up wash fluid! ■



Brake system

The warning light  lights up when the brake fluid level is too low or there is a fault in the ABS.

If the warning light flashes  and an audible signal sounds three times, **stop** and check the brake fluid level ⇒ .

The following text will be displayed in the information display:

Brake fluid: Owner's manual Car documentation!

If there is a fault in the ABS which also influences the function of the brake system (e.g. distribution of brake pressure), the ABS warning light  comes on and at the same time the brake system warning light starts flashing . Be aware that not only the ABS but also another part of the brake system is defective ⇒ .

An audible signal sounds three times as an additional warning signal.

One should get used to high pedal forces, long braking distances and long free play of the brake pedal when driving to the next specialist garage.

For further information on the brake system ⇒ page 163, "Brakes".

WARNING

- Pay attention to the following instructions ⇒ page 188, "Working in the engine compartment" before checking the brake fluid level and opening the bonnet.
- If the brake system warning light  does not go out a few seconds after switching on the ignition or comes on when driving, stop immediately and check the brake fluid in the reservoir ⇒ page 193. If the fluid level has dropped below the MIN marking, do not drive any further - risk of accident! Contact a Škoda dealer to obtain professional assistance. ■

Hand break

The warning light  also comes on if the handbrake is applied. An audible warning is also given if you drive the vehicle for at least 3 seconds at a speed of more than 6 km/h.

The following text will be displayed in the information display:



Release parking brake! ■

Alternator

The warning light  comes on after the ignition has been switched on. It should go out after the engine has started.

If the warning light does not go out after the engine has started, or comes on when driving, drive to the nearest specialist garage. The vehicle battery will be discharged in this case so switch off all non-essential electrical components.

Caution

If the warning light  comes on when driving and in addition the warning light  (cooling system fault) also comes on in display, you must then stop the car immediately and switch the engine off - risk of engine damage! ■

Engine oil level

Warning light lights up

If the warning light  lights up, the quantity of oil in the engine is probably too low. Check as soon as possible the oil level or top up ⇒ page 190, "Replenishing engine oil" with engine oil.

A peep sounds as an additional warning signal.

The following text will be displayed in the information display:

Check oil level!

The warning light will go out if the bonnet is left open for more than 30 seconds. If no engine oil has been replenished, the warning light will come on again after driving about 100 km.

Warning light flashes

A fault on the engine oil level sensor is indicated additionally by an audible signal and the warning light coming on several times after the ignition has been switched on.

In this case have the engine inspected without delay by a specialist garage.

The following text will be displayed in the information display:

Oil sensor workshop! ■

Fuel reserve

The warning light  comes on, if the fuel level is still below 9 litres.

An audible signal sounds as an additional warning signal.

The following text will be displayed in the information display:

Please refuel! Range...km

Note

The Text in the information display goes out only after refuelling and driving a short distance. ■

Temperature of the clutches of the automatic gearbox DSG

In the event that the temperature of the clutches of the automatic gearbox DSG is too high, the symbol and the warning are shown in the  Information display:

Gearbox overheated. Stop! Owner's man!

An audible signal sounds as an additional warning signal.

	WARNING
If you must stop for technical reasons, then park the vehicle at a safe distance from the traffic and switch off the engine and switch on the hazard warning light system.	

Caution

In the event that the clutches of the automatic gearbox have overheated, bring the vehicle to a stop and switch off the engine. You must wait until the symbol  and the warning go out - risk of gearbox damage! You can continue the trip as soon as the symbol and the warning go out. ■

Unlocking and locking

Vehicle key

Description

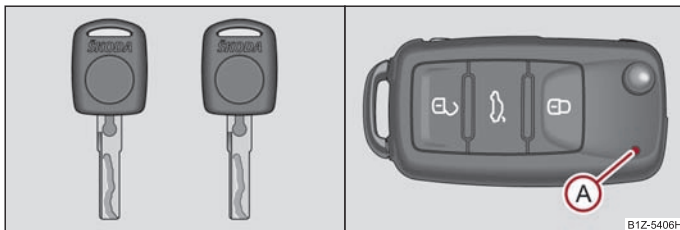

Fig. 22 Set of keys without remote control/Keys with remote control key

Two keys are provided with the vehicle. Depending on the equipment, your vehicle can be equipped with keys without radio remote control ⇒ fig. 22 - left, or with radio remote control ⇒ fig. 22 - right.

! WARNING

- Always withdraw the key whenever you leave the vehicle - even if it is only for a short time. This is particularly important if children are left in the vehicle. The children might otherwise start the engine or operate electrical equipment (e.g. power windows) - risk of injury!
- Do not withdraw the ignition key from the ignition lock until the vehicle has come to a stop. The steering lock might otherwise engage unintentionally - risk of accident!

! Caution

- Each key contains electronic components; therefore protect them against moisture and severe shocks.
- Keep the groove of the keys absolutely clean as impurities (textile fibres, dust etc.) have a negative effect on the proper operation of the locking cylinder and the ignition lock.

i Note

Please approach an authorised Škoda Service Partner if you lose a key since he can obtain a new one for you. ■

Changing the battery in the remote control key

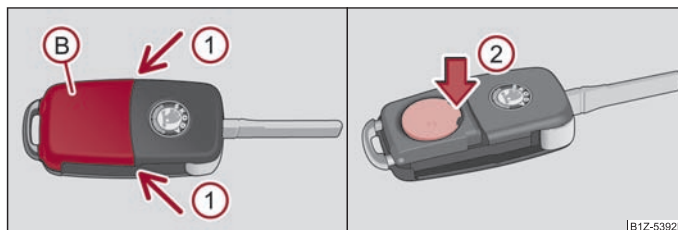

Fig. 23 Remote control key - remove cover/remove battery

Each remote control key contains a battery which is housed under the cover (B) ⇒ fig. 23. If the battery is discharged, the red warning light (A) does not flash after you press a button on the remote control key ⇒ fig. 22. We recommend that you have the batteries of the key replaced by an authorised Škoda Service Partner. You should, however, proceed as follows if you wish to replace the discharged battery yourself:

- Fold open the key.
- Press off the battery cover with your thumb or using a flat screwdriver at the points of the arrows (1) from ⇒ fig. 23.
- Remove the discharged battery from the key by pressing the battery downwards at the point of the arrow (2) ⇒ fig. 23.
- Insert the new battery. Ensure that the "+" symbol on the battery is facing upwards. The correct polarity is shown on the battery cover.
- Position the battery cover on the key and press on it until it is heard to lock in place.



For the sake of the environment

Dispose of a used battery in accordance with environmental regulations.



Note

- Pay attention to the correct polarity when changing the battery.
- The replacement battery must have the same specification as the original battery.
- If it is still not possible to unlock or lock the vehicle with the remote control key even after replacing the battery, this means that the system has to be synchronised ⇒ page 42. ■

Electronic immobiliser

The electronic immobiliser prevents the vehicle being operated by an unauthorised person.

An electronic chip is integrated in the head of the key. The immobiliser is deactivated with the aid of this chip when the key is inserted in the ignition lock. The electronic immobiliser is automatically activated when you withdraw the ignition key from the lock.



Note

It is only possible to start the engine of your car with a Genuine Škoda key with the matching code. ■

Child safety lock

The child safety lock prevents the rear door from being opened from the inside.

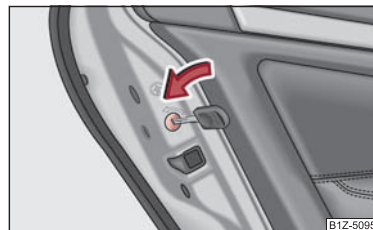

Fig. 24 Child safety locks on the rear doors

The rear doors are equipped with a child safety lock. You can switch the child safety lock on and off using the vehicle key.

Switching child safety lock on

- Use the vehicle key to turn the slit in the rear door to the left in the direction of the arrow ⇒ fig. 24.

Switching child safety lock off

- Use the vehicle key to turn the slit to the right against the direction of the arrow.

So long as the child safety lock is switched on it is not possible to open the door from the inside with the door opening lever. In this case the door can be opened only from the outside. ■

Central locking system

Description

When using the central locking and unlocking system, **all** the doors and the fuel filler flap are locked or unlocked at the same time (if it was not set differently in the menu point **Settings - Convenience** of the information display). The boot lid is unlocked when opening. It can be opened by pressing the hand grip above the licence plate ⇒ page 39. ▶

Operation of the central locking system is possible:

- from the outside using the vehicle key ⇒ page 38,
- using the buttons for the central locking system ⇒ page 38,
- with a remote control key ⇒ page 41,

Indicator light in the driver's door

After locking the vehicle, the warning light flashes for around 2 seconds in quick succession, afterwards it begins to flash evenly at longer intervals.

If the vehicle is locked and the safe securing system ⇒ page 37 is not operating, the indicator light in the driver door flashes for about 2 seconds fast, goes out and starts to flash evenly at longer intervals after about 30 seconds.

If the indicator light first of all flashes fast for about 2 seconds, afterwards lights up for about 30 seconds and then flashes slowly, there is a fault in the system of the central locking or the interior monitor ⇒ page 43. Visit a specialist garage to obtain assistance.

Convenience operation of windows

One can open and close the electrically powered windows when unlocking and locking the vehicle ⇒ page 45.

Opening a single door

This function makes it possible to only unlock the driver's door. The other doors and the fuel filler flap remain locked and are only unlocked after repetitive unlocking.

This function can be activated/deactivated by a specialist garage.

On vehicles with an information display, this function can be switched on in the menu **Settings Convenience - Door open**.

Automatic locking and unlocking

All the doors and the boot lid are locked automatically once the car reaches a speed of about 15 km/h.

If the ignition key is withdrawn, the car is then automatically unlocked again. In addition, it is possible for the driver to unlock the car by pressing the central locking button  or by pulling the door opening lever.

This function can be activated/deactivated by a specialist garage.

On vehicles with an information display, this function can be switched on in the menu **Settings Convenience - Door open**.



WARNING

Locking the doors prevents involuntary opening in an exceptional situation (an accident). Locked doors prevent unwanted entry into the vehicle from outside, for example at road crossings. Locked doors do, however, make it more difficult for rescuers to get into the vehicle in an emergency - danger to life!



Note

- In the event of an accident in which the airbags are deployed, the locked doors are automatically unlocked in order to enable rescuers to gain access to the vehicle.
- Only the front door which is fitted with a locking cylinder can be unlocked and locked using the key if the central locking system fails. You can lock or unlock manually the other doors and the boot lid.
 - Emergency locking of the door ⇒ page 39.
 - Emergency unlocking of the boot lid ⇒ page 40. ■

Safe securing

The central locking system is equipped with a **safe securing** system. Locking the vehicle from the outside causes the door locks to be automatically blocked. The warning light flashes for around 2 seconds in quick succession, afterwards it begins to flash evenly at longer intervals. It is not possible to open the doors with the door handle either from the inside or from the outside. This acts as an effective deterrent for attempts to break into your vehicle.

You can deactivate the safe securing system by locking twice within 2 seconds.

If the safe securing system is not operating, the warning light in the driver door flashes for about 2 seconds fast, goes out and starts to flash evenly at longer intervals after about 30 seconds.

The safe securing system is again activated the next time the vehicle is unlocked and locked again.

The doors can be opened from the inside if the vehicle is locked and the safe securing system is deactivated:

- The door is unlocked by actuating the door-opening lever.
- The door opens upon actuating the door-opening lever again. ►

WARNING

If the vehicle is locked from the outside and the safe securing system is activated, there must not be any person and animals in the vehicle as it is then not possible to open either a door or a window from the inside. The locked doors make it more difficult for rescuers to get into the vehicle in an emergency - hazard!

Note

- The anti-theft alarm system is also activated with the deactivated safe securing system when locking the vehicle. The interior monitor is however not activated.
- When activating the Safelock function after you lock the vehicle, the message **CHECK DEADLOCK!** will appear to inform you about this. In vehicles equipped with an information display, the message **Check deadlock! appears Owner's manual!** appears. ■

Unlocking the vehicle using the key

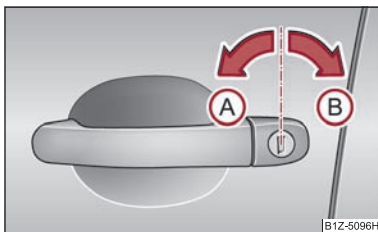

Fig. 25 Turning the key for unlocking and locking the vehicle

- Turn the key in the locking cylinder of the driver's door in the direction of travel (unlock position) **(A)** ⇒ fig. 25.
- Pull on the door handle and open the door.
- All the doors (only the driver's door on vehicles with anti-theft alarm system) and the fuel filler flap are unlocked.
- The boot lid is then unlocked.
- The switched on interior lights come on over the door contact.
- The safe securing system is deactivated.
- The windows open provided the key is **held** in the unlock position.

- The indicator light in the driver door stops flashing if the car is not fitted with an anti-theft alarm system ⇒ page 42.

Note

If the vehicle is equipped with an anti-theft alarm system, you must insert the key into the ignition lock and switch the ignition on within 15 seconds after unlocking the door in order to deactivate the anti-theft alarm system. The **alarm will be triggered** if you do **not switch on** the ignition within 15 seconds. ■

Locking the vehicle with the key

- Turn the key in the locking cylinder of the driver's door in the opposite direction of travel (lock position) **(B)** ⇒ fig. 25.
- The doors, the boot lid and the fuel filler flap are locked.
- The switched on interior lights will switch off over the door contact.
- The windows and the electric sliding/tilting roof close provided the key is **held** in the lock position.
- The safe securing system is activated immediately.
- The indicator light in the driver door begins flashing.

Note

If the driver's door has been opened, the vehicle cannot be locked. ■

Button for the central locking system



Fig. 26 Centre console: Central locking system

If the vehicle was not locked from the outside, you can also unlock and lock it with the rocker switch without the ignition switched on.

Locking all doors and the boot lid

- Press button ① ⇒ page 38, fig. 26. The symbol  in the button comes on.

Unlocking all doors and the boot lid

- Press button ② ⇒ page 38, fig. 26. The symbol  goes out in the button.

The following applies if you have locked your vehicle using the button ①:

- It is not possible to open the doors or the boot lid from the outside (safety feature, e.g. when stopping at traffic lights etc.).
- You can unlock the doors individually from the inside and open them by pulling the door opening lever.
- As long as one door is opened⁶⁾, the vehicle cannot be locked in order to avoid inadvertently locking the key in the vehicle.
- In the event of an accident in which the airbags are deployed, the locked doors are automatically unlocked from the inside in order to enable rescuers to gain access to the vehicle.

By pressing and holding the button ① or ②, you can conveniently close or open the windows ⇒ page 45.

WARNING

The central locking system also operates if the ignition is switched off. All the doors and the boot lid are locked. Children should never be left unattended in the vehicle since it is difficult to provide assistance from the outside when the doors are locked. Locked doors make it difficult for rescuers to get into the vehicle in an emergency - hazard!

Note

The door opening lever and the buttons for the central locking system do not operate if the safe securing system is activated ⇒ page 37. ■

⁶⁾ Is not valid for the boot lid.

Emergency locking of the doors

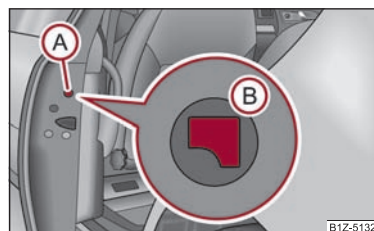

Fig. 27 Rear door: Emergency locking of the door

An emergency locking mechanism is located on the rear side of the doors which have no locking cylinder; it is only visible after opening the door.

Locking

- Remove the panel A ⇒ fig. 27.
- Insert the key into the opening under the panel and press the stopping lever B as far as the stop toward the inside.
- Re-insert the panel.

After closing the door, you can no longer open it from outside. The door can be unlocked from the inside by pulling on the door handle again, and then opened from the outside. ■

Boot lid



Fig. 28 Handle of boot lid

Open the boot lid by pressing the hand grip above the licence plate after unlocking the vehicle using the key or the radio remote control.

Opening the boot lid

- Press on the handle ⇒ page 39, fig. 28 and at the same time raise the boot lid.

Closing the boot lid

- Pull the boot lid down and close it with a slight swing ⇒ ⚠.

A handle which makes the closing easier is located on the inner paneling of the boot lid.



WARNING

- Ensure that the lock is properly engaged after closing the boot lid. Otherwise, the boot lid might open suddenly when driving even if the boot lid lock is closed - risk of accident!
- Never drive with the boot lid fully opened or slightly ajar otherwise exhaust gases may get into the interior of the vehicle - risk of poisoning!
- Do not press on the rear window when closing the boot lid, it could crack - risk of injury!



Note

- After closing the boot lid, it is automatically locked within 1 second and the anti-theft alarm system is activated. This applies only if the vehicle was locked before closing the boot lid.
- The function of the hand grip above the licence plate is deactivated when starting off or as of a speed of more than 5 km/hour for vehicles with central locking. The function of the hand grip is activated again when the vehicle has stopped and a door is opened. ■

Emergency unlocking of the boot lid (Octavia)

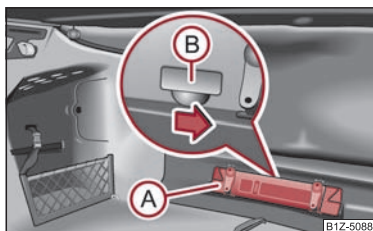

Fig. 29 Emergency unlocking of the boot lid

If there is a fault in the central locking, you can open the boot lid as follows:

- Fold the backrest of the rear seat forwards ⇒ page 68.
- Take out the warning triangle (A) ⇒ fig. 29.
- Press the operating lever in the direction of arrow in order to unlock the boot lid. The operating lever is located under the panel (B).
- Open the boot lid/luggage compartment door. ■

Emergency unlocking of the boot lid (Estate car)

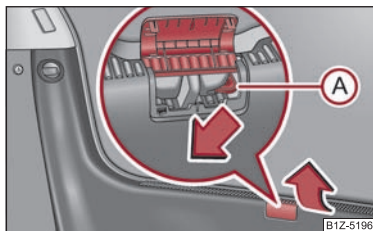

Fig. 30 Emergency unlocking of the boot lid

If there is a fault in the central locking, you can open the boot lid as follows:

- Fold the backrest of the rear seat forwards ⇒ page 68.
- Open up the cover of the lock upwards ⇒ fig. 30. ▶

- Move the operating lever **A** with the aid of a narrow object e.g. screwdriver up to the stop in the direction of arrow; the boot lid is then unlocked.
- Open the boot lid/luggage compartment door. ■

Remote control

Description

You can use the remote control key:

- to unlock and lock the car,
- unlocking boot lid,
- electrically open and close the windows.

The transmitter with the battery is housed in the handle of the remote control key. The receiver is located in the interior of the car. The operating range of the remote control key is approx. 10 m. But this range of the remote control can be reduced if the batteries are weak.

The key has a fold-open key bit which can be used for unlocking and locking the car manually and also for starting the engine.

If a lost key is replaced or if the receiver unit has been repaired or a new unit installed, it is then necessary for an authorised Škoda Service Partner to initialise the system. Only after this is it possible to again use the remote control key.

Note

- The remote control is automatically deactivated when the ignition is switched on.
- The operation of the remote control may temporarily be affected by interference from transmitters close to the car and which operate in the same frequency range (e.g. mobile phone, TV transmitter).
- The battery must be replaced if the central locking or anti-theft alarm system does react to the remote control at less than 3 metres away ⇒ page 35.
- If the driver door is opened, the vehicle cannot be locked using the remote control. ■

Unlocking and locking car

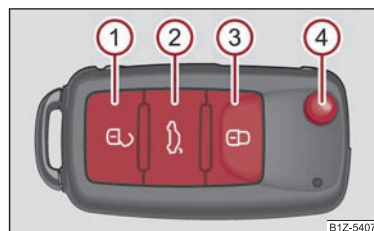

Fig. 31 Remote control key

Unlocking the vehicle

- Press the button **1** ⇒ fig. 31 for about 1 second.

Locking the vehicle

- Press button **3** for about 1 second.

Deactivating safe securing system

- Press button **3** twice in 2 seconds. Further information ⇒ page 37.

Boot lid remote release

- Press button **2** for about 1 second. Further information ⇒ page 39.

Folding out of the key

- Press button **4**.

Folding up of the key

- Press button **4** and collapse the key bit in the housing.

The turn signal lights flash twice as confirmation that the vehicle has been unlocked. The vehicle will lock again automatically if you unlock the vehicle using button **1** but do not open a door or the boot lid within the next 30 seconds. The safelock and/or anti-theft alarm system will reactivate. This function is intended to prevent the car being unlocked unintentionally. ►

In addition, when the car is unlocked, the electrically adjustable seats and exterior mirrors move into the position assigned to this key. The stored setting of driver seat and exterior mirrors is retrieved.

Display of the locking

The turn signal lights flash once to confirm that the vehicle has been correctly locked.

If the vehicle is locked by pressing the button  and some doors or the boot lid are not closed, the turn signal lights flash only after closing.





WARNING

If the vehicle is locked from the outside and the safe securing system is activated, there must not be any person in the vehicle as it is then not possible to open either a door or a window from the inside. The locked doors make it more difficult for rescuers to get into the vehicle in an emergency - hazard!



Note

- Operate the radio remote control only when the doors and boot lid are closed and you have visual contact with the vehicle.
- Once in the car, you must not press the lock button  of the radio remote control before inserting the key into the ignition lock in order to avoid the car being inadvertently locked and the alarm system being switched on. Should this happen, press the unlock button  of the radio remote control. ■

Synchronisation of the remote control

If the vehicle cannot be unlocked by actuating the remote control system then it is possible that the code in the key and the control unit in the vehicle are no longer synchronised. This can occur when the buttons on the radio-operated key are actuated a number of times outside of the operative range of the equipment or the battery on the remote control was replaced.

This means it is necessary to synchronise the code as follows:

- press any button on the remote control;
- pressing of the button means that the door will unlock with the key within 1 minute. ■

Anti-theft alarm system

Description

The anti-theft alarm system increases the level of protection against people seeking to break into the vehicle. The system triggers audible and visual warning signals if an attempt is made to break into the vehicle.

How is the alarm system activated?

The anti-theft alarm system is activated automatically when the vehicle is locked with the key on the driver's door or by using the radio remote control. It is activated 30 seconds after locking the door.

How is the alarm system deactivated?

The anti-theft alarm system is deactivated if the vehicle is unlocked by only using the radio remote control. The anti-theft alarm system is reactivated if the vehicle is not opened within 30 seconds after transmitting the radio signal.

Once you unlock the vehicle by inserting the key into the driver door you then have to insert the key into the ignition lock and switch the ignition on within 15 seconds after opening the door in order to deactivate the anti-theft alarm system. The **alarm will be triggered** if you do **not switch on** the ignition within 15 seconds.

When is the alarm triggered?

The following security areas of the locked vehicle are monitored:

- Bonnet,
- Boot lid,
- Doors,
- Ignition lock,
- Vehicle inclination ⇒ page 43,
- Vehicle interior ⇒ page 43,
- A drop in voltage of the on-board power supply,
- Socket of the factory-fitted towing device.

An alarm is immediately triggered if either of the two battery terminals is disconnected while the anti-theft alarm system is activated.

How is the alarm switched off?

You switch the alarm off if you unlock the vehicle with the radio remote control or if you switch the ignition on. ►



i Note

- The working life of the alarm siren is 6 years. More detailed information is available by a specialist garage.
- Before leaving the car, check that all the doors, windows and the electric sliding/tilting roof are properly closed in order to ensure that the anti-theft alarm system is fully operational.
- Coding of the radio remote control and the receiver unit precludes the use of the radio remote control from other vehicles. ■

Interior monitor and Towing protection monitoring

Fig. 32 Button for interior monitor and towing protection monitoring

Switch off the interior monitor and towing protection monitoring

- Switch off the ignition.
- Open the driver door.
- Press the button  at the centre column on the driver side ⇒ fig. 32, the symbol  which lights up in the button changes from red to orange.
- Lock the vehicle within 30 seconds.

The interior monitor and the towing protection monitoring are switched on again automatically the next time the car is locked.

i Note

- You can switch the interior monitor and the towing protection monitoring off if there is a possibility that movements from (e.g. children or animals) inside the vehicle interior or if the vehicle must be transported (e.g. by train or ship) or towed, might trigger the alarm.

- You can also switch off the interior monitor and the towing protection monitoring, by deactivating the safe securing system ⇒ page 37.
- The opened storage compartment for spectacles reduces the effectiveness of the interior monitor. In order to ensure the function of the interior monitor to be fully operational, always close the storage compartment for spectacles before locking the vehicle. ■

Power windows**Buttons on the driver's door**

Fig. 33 Buttons on the driver's door

The power windows operate only when ignition is switched on.

Opening a window

- A window is opened by pressing lightly on the respective button in the door. The process stops when one releases the button.
- Additionally you can open the window automatically (fully opened) by pressing the button up to the stop. Renewed pressing of the button causes the window to stop immediately.

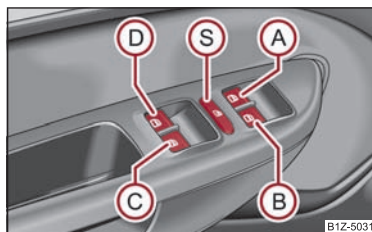
Closing a window

- A window is closed through pulling lightly on the respective button in the door. The closing process stops when one releases the button.
- Additionally you can close the window automatically (fully closed) by pulling the button up to the stop. Renewed pulling of the button causes the window to stop immediately. ▶

The buttons for the individual windows are located in the armrest of the driver's door ⇒ page 43, fig. 33, front passenger seat and in the rear doors ⇒ page 44.

Buttons for the power windows in the armrest for the driver

- Ⓐ Button for the power window in the driver's door
- Ⓑ Button for the power window in the front passenger's door
- Ⓒ Button for the power window at the rear right door
- Ⓓ Button for the power window at the rear left door
- Ⓢ Safety switch

Safety pushbutton

You can deactivate the buttons for power windows at rear doors by pressing the safety pushbutton Ⓢ ⇒ page 43, fig. 33. The buttons for power windows at rear doors are activated again by pressing the safety pushbutton Ⓢ again.

If the buttons for the rear doors are deactivated, the indicator light Ⓢ in the safety switch Ⓢ lights up.

WARNING

- If you lock the vehicle from the outside, do not leave any person in the vehicle since it is no longer possible to open the windows from the inside in an emergency.
- The system is fitted with a force limiter ⇒ page 45. If there is an obstacle, the closing process is stopped and the window goes down by several centimetres. You should then take particular care when closing the windows! You may otherwise suffer severe injuries as a result of getting an arm, for example, jammed in the window!
- It is recommended to deactivate the electrically operated power windows in the rear doors (safety pushbutton Ⓢ ⇒ page 43, fig. 33) when children are being transported on the rear seats.

Caution

- Keep the window glass clean to ensure correct function of the electric windows.
- In the event of a freezing up of the windscreen, first of all eliminate the ice ⇒ page 179 and then operate the power windows otherwise the power window mechanism could be damaged.

Note

- After switching the ignition off, it is still possible to open or close the windows for a further 10 minutes. During this time the automatic closing and opening functions of the window will operate. The power windows are switched off completely once you open the driver or front passenger door.
- When driving always use the existing heating, air conditioning and ventilation system for ventilating the interior of the vehicle. If the windows are opened, dust as well as other dirt can get into the vehicle and in addition the wind noise is more at certain speeds. ■

Button in the front passenger door and in the rear doors



Fig. 34 Position of button in front passenger door

A button for the relevant window is provided in these doors.

Opening a window

- Lightly press the appropriate button **down** and hold it until the window has moved into the desired position.
- Additionally you can open the window automatically (fully opened) by pressing the button **down** up to the stop. Renewed pressing of the button causes the window to stop immediately.

Closing a window

- Lightly press the appropriate button **up** and hold it until the window has moved into the desired position.
- Additionally you can close the window automatically (fully closed) by pressing the button **up** up to the stop. Renewed pressing of the button causes the window to stop immediately. ▶

⚠ WARNING

The system is fitted with a force limiter ⇒ page 45. If there is an obstacle, the closing process is stopped and the window goes down by several centimetres. You should then take particular care when closing the windows! You may otherwise suffer severe injuries as a result of getting an arm, for example, jammed in the window!

ℹ Note

- After switching the ignition off, it is still possible to open or close the windows for a further 10 minutes. During this time the automatic closing and opening functions of the window will operate. The power windows are switched off completely once you open the driver or front passenger door.
- If the child safety lock is switched on, the lighting of the switch for the window lifter in the rear doors is not activated. ■

Force limiter of the power windows

The electrically operated power windows are fitted with a force limiter. It reduces the risk of bruises or injuries when closing the windows.

If there is an obstacle, the closing process is stopped and the window goes down by several centimetres.

If the obstacle prevents the window from being closed during the next 10 seconds, the closing process is interrupted once again and the window goes down by several centimetres.

You must try to close the window once again within 10 seconds after the window has gone down twice, even if the obstacle was not yet removed, the closing process is stopped. During this time it is not possible to automatically close the window. The force limiter is still switched on.

The force limiter is only switched off, if you attempt to close the window within the next 10 seconds - **the window closes now with full strength!**

If you wait longer than 10 seconds, the force limiter is switched on again.

⚠ WARNING

You should take particular care when closing the windows! You may otherwise suffer severe injuries as a result of getting an arm, for example, jammed in the window! ■

Window convenience operation

You can open and close the electrically powered windows as follows when unlocking and locking the vehicle (only close the sliding/tilting roof):

Opening a window

- Hold the key in the locking cylinder of the driver's door in the unlock position or press the unlock button of the radio remote control until all the windows are opened.

Closing a window

- Hold the key in the locking cylinder of the driver's door in the lock position or press the lock button of the radio remote control until all the windows are closed.

You can interrupt the opening or closing operation of the windows immediately by releasing the key or the lock button.

⚠ WARNING

The system is fitted with a force limiter ⇒ page 45. If there is an obstacle, the closing process is stopped and the window goes down by several centimetres. You should then take particular care when closing the windows! You may otherwise suffer severe injuries as a result of getting an arm, for example, jammed in the window!

ℹ Note

On vehicles fitted with anti-theft alarm system the convenience window opening is possible by means of the key in the locking cylinder only 45 seconds after deactivating the warning system or after activating the anti-theft alarm system. ■

Operational faults**Electrically operated power windows do not operate**

If the battery of the car has been disconnected and then reconnected, the electrically operated power windows do not operate. The system must be activated. Proceed as follows in order to re-establish the function:

- Switch on the ignition, ▶

- slightly pull on the upper edge of the relevant button and hold it until the window is closed,
- release the switch,
- you must pull the respective switch again in upward direction for approx. 3 seconds.

Operation in winter

Ice accumulating on the surface of the windows during the winter may result in a greater resistance when closing the windows and the window may stop and move back several centimetres

It is necessary to put the force limiter out of operation in order to close the window ⇒ page 45, "Force limiter of the power windows".

WARNING

The system is fitted with a force limiter ⇒ page 45. If there is an obstacle, the closing process is stopped and the window goes down by several centimetres. You should then take particular care when closing the windows! You may otherwise suffer severe injuries as a result of getting an arm, for example, jammed in the window!

Caution

- Keep the window glass clean to ensure correct function of the electric windows.
- In the event of a freezing up of the windscreen, first of all eliminate the ice ⇒ page 179 and then operate the power windows otherwise the power window mechanism could be damaged. ■

Electric sliding/tilting roof

Description

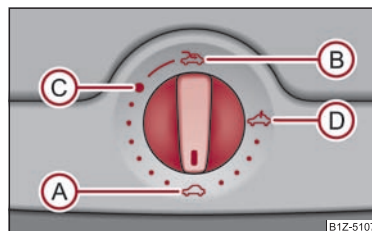

Fig. 35 Detail of the headliner: Control dial for the power sliding/tilting roof

The sliding/tilting roof is operated by means of the control dial ⇒ fig. 35 and only functions when the ignition is switched on. The control dial has several positions.

After switching the ignition off, it is still possible to open, close and tilt the sliding/tilting roof for approx. 10 minutes. It is no longer possible to operate the sliding/tilting roof after opening one of the front doors, however.

Note

If the battery has been disconnected and reconnected, it is possible that the sliding/tilting roof does not close fully. Here you have to set the control dial to the switch position **A** and press it forward for about 10 seconds. ■

Opening and tilting

Comfort position

- Turn the switch to position **C** ⇒ fig. 35.

Opening fully

- Turn the switch to position **B** and hold it in this position (spring-tensioned position).

Tilting roof

- Turn the switch to position **D**.



When the sliding/tilting roof is in the comfort position, the intensity of the wind noise is much less.

The sun screen is also opened automatically when the roof slides open. You can slide the sun screen into the opened or closed position by hand when the sliding/tilting roof is closed.

⚠ Caution

It may be necessary during winter to remove any ice and snow in the area of the sliding/tilting roof before opening it in order to prevent damaging the opening mechanism and the seal. ■

Closing

Sliding closed/closing the sliding/tilting roof

- Turn the switch to position **A** ⇒ page 46, fig. 35.

Safety closing

The sliding/tilting roof is fitted with a force limiter. If an obstacle (e.g. ice) prevents closing, the sliding/tilting roof stops and opens completely. You can close the sliding/tilting roof completely without force limiter by pressing the switch to the **A** position ⇒ page 46, fig. 35 at the front for as long as it takes for the sliding/tilting roof to close completely ⇒ ⚠.

⚠ WARNING

Close the sliding/tilting roof carefully - risk of injury! ■

Convenience operation

You can also close an open sliding/tilting roof from the outside.

- Hold the key in the locking cylinder of the driver's door in the lock position or press the lock button of the radio remote control until the sliding/tilting roof is closed ⇒ ⚠.

The closing operation stops when one releases the key or the lock button.

⚠ WARNING

Close the sliding/tilting roof carefully - risk of injury! The force limiter does not operate with the convenience closing. ■

Emergency operation

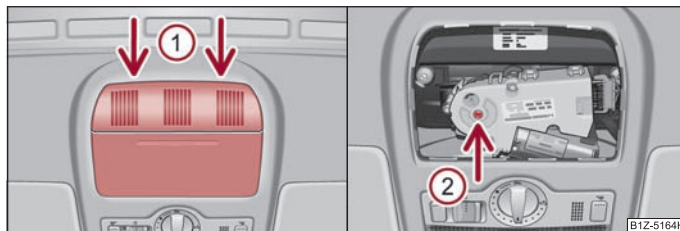

Fig. 36 Detail of the headliner: Points for positioning screwdriver/opening for positioning the key

You can close and/or open the sliding/tilting roof by hand if the system is defect.

- Position the flat blade of a screwdriver carefully against the rear edge of the cover for the electrical drive at the points of the arrows **1** ⇒ fig. 36 on the left.
- Pull the cover down.
- Insert an Allen key, Group 4, up to the stop into the opening at the point of the arrow **2** and close and/or open the sliding/tilting roof ⇒ fig. 36 on the right.
- Press on the cover again by first of all inserting the plastic lugs and then pushing the cover up.
- Have the fault rectified by a specialist workshop.

i Note

It is necessary after each emergency operation (using Allen key) to move the sliding/tilting roof into the basic position. Here you have to set the control dial to the switch position **A** ⇒ page 46, fig. 35 and press it forward for about 10 seconds. ■

Lights and Visibility

Lights

Switching Switching lights on and off



Fig. 37 Dash panel: Light switch

Switching on side lights

- Turn the light switch \Rightarrow fig. 37 into position \Rightarrow .

Switching on the low beam and main beam

- Turn the light switch into position \Rightarrow .
- Push the main beam lever slightly forward in the spring-tensioned position in order to switch on the main beam \Rightarrow page 54, fig. 43.

Switching off lights (except daylight driving lights)

- Turn the light switch into position.

The dipped beam continues to shine while the ignition is switched on and the light switch is in the position \Rightarrow or **AUTO**. After switching off the ignition, the low beam is switched off automatically and only the side lights come on. The parking light also goes out after the ignition is removed.

On vehicles with separate lights for daylight driving lights in the fog lights or in the front bumper, the low beam does not light up when the light switch is in position 0 even if the ignition is switched on.

On models fitted with **right-hand steering** the position of certain switches differs from that shown in \Rightarrow fig. 37. The symbols which mark the switch positions are identical, however.

WARNING

Never drive with only the side lights on - risk of accident! The side lights are not bright enough to light up the road sufficiently in front of you or to be seen by other oncoming traffic. In this case, always switch on the low beam when it is dark or if visibility is poor.

Note

- If the light switch is in the position \Rightarrow , the ignition key is removed and the driver's door is open, an acoustic warning signal will sound. The acoustic warning signal is switched off over the door contact when the driver's door is closed (ignition off). The vehicle can be parked with the side lights on.
- If the light switch is in the position \Rightarrow and the ignition key is removed, the lights will go out.
- If the car is parked for a lengthy period, we recommend switching off all lights, or leaving only the parking lights switched on.
- The switching on of the described lights should only be undertaken in accordance with the legal requirements.
- If a fault occurs in the light switch, the low beam comes on automatically
- In the event of cool or humid weather conditions, the headlights can be misted up from the inside.
 - The temperature difference between interior and external area of the headlight lenses is decisive.
 - When the driving lights are switched on, the light outlet surfaces are free from mist after a short period. The headlight lenses can possibly mist up at the border areas.
 - It also concerns reverse light and turn signal lights.
 - This mist has no influence on the life of the lighting system. ■

"DAY LIGHT"

Switching on daylight driving lights

- Switch on the ignition without turning the light switch out of the position 0 or **AUTO**. 

Deactivating the function daylight driving lights

- Pull the turn signal light lever towards the steering wheel up to 3 seconds after switching on the ignition and at the same time, slide it to the bottom and hold it in this position for at least 3 seconds.

Activating the function daylight driving lights

- Pull the turn signal light lever towards the steering wheel up to 3 seconds after switching on the ignition and at the same time, slide it to the top and hold it in this position for at least 3 seconds.

On vehicles fitted with an information display, you can also activate or deactivate in the menu the function daylight driving lights:

- Settings
- Lights & Vision

On vehicles with separate lights for daylight driving lights in the fog lights or in the front bumper, the parking lights and the licence plate light do not come on when activating the function daylight driving lights (neither front nor rear).

If the vehicle is not equipped with separate lights for daylight driving lights, the combination of the low beam, the parking lights (front and rear) including the licence plate light is used as daylight driving lights.

In some countries, the national legal provisions require that the rear parking lights also come on together with the separate lights for daylight driving lights when activating the function daylight driving lights.

When the daylight driving lights are switched on, the illumination of the instrument cluster is switched off, however, it is switched on in the position **AUTO** when it is dark and the low beam shines with full brightness (100 % of the performance). ■

Automatic driving lamp control



Fig. 38 Dash panel: Light switch

Switching on automatic driving lamp control

- Turn the light switch ⇒ fig. 38 into position **AUTO**.

Switching off automatic driving lamp control

- Turn the light switch to the position 0, ☞ or ☜.

If the light switch is in the position **AUTO**, the symbol illuminates when the ignition is switched on **AUTO** next to the light switch. If the low beam is activated with the light sensor, the symbol ☞☜ illuminates additionally next to the light switch.

If the light comes on automatically, the side lights and low beam as well as licence plate light light up at the same time.

If the automatic light control is switched on, the light is regulated with the light sensor in the rear mirror holder. If the light intensity drops below the set value, e.g. when driving during the day into a tunnel, the low beam and the side lights as well as the licence plate light come on automatically. If the light intensity increases again, the lights switch off automatically.

Motorway lights

If the automatic light control has been switched on and the vehicle speed is over 140 km/h for at least 10 seconds, the side lights and low beam are switched on automatically.

If the vehicle speed is below 65 km/h for at least 2 minutes, the lights are switched off.

Rain lights

If you switch on the windscreen wipe in the operation rain sensor for longer than 10 seconds or in the operation permanent wipe (position 2 or 3) ⇒ page 58 switching on for longer than 15 seconds, the side lights and low beam are switched on automatically. The light switches off if the windscreen wipe is in operation rain sensor for more than around 4 minutes or is not switched on in the operation permanent wipe.



WARNING

The automatic light control only operates as a support. The driver is not released from his responsibility to inspect the light and if necessary to switch on the light depending on the light conditions. The light sensor cannot detect for example rain or snow. For these conditions we recommend to switch on the low beam ☜☞!

**Note**

- Do not affix any stickers in front of the light sensor, so that you do not impair its function or put it out of operation.
- The same principles as for using the automatic light control also apply to the light which is switched on manually ⇒ page 48. ■

Cornering lights

The cornering lights are used to illuminate the curves by means of the cone of light swiveling together with the front headlight with Xenon lights. This function is active when the speed of the car increases to more than 10km/h.

The swiveling function of the headlights can be switched off/on via the menu point **Assistants** in the main menu of the information display ⇒ page 23.

**WARNING**

If the cornering lights are defective, the headlights are automatically lowered to the emergency position, which prevents a possible dazzling of oncoming traffic. Thus the illuminated length of the road is shortened. Drive carefully and have the car inspected immediately by a specialist garage. ■

Parking light

Parking light P<

- Switch off the ignition.
- Pull the turn signal light lever ⇒ page 54, fig. 43 upwards or downwards - the parking light on the right and left side of the vehicle will be switched on respectively.

The parking light only operates if the ignition is switched off.

If you have switched on the right or left turn signal light and you switch off the ignition, the parking light is not automatically switched on.

Parking light on both sides

- Turn the light switch into the position and lock the vehicle. ■

Coming Home Function

The function makes it possible to switch on the lights in the darkness for a short time after leaving the vehicle.

Switching on Coming Home Function

- The light switch is in the position automatic driving lamp control **AUTO** and the low beam illuminates.
- Switch off the Ignition.
- After opening the driver's door, the function Coming Home is switched on.
- Close all the doors and the boot lid and lock the vehicle. After a short time, switch all lights off.

Depending on equipment fitted the function Coming Home switches on the following lights:

- Parking lights,
- Low beam,
- Entry lighting in the exterior mirrors,
- Licence plate light.

Coming Home Function

The lights go out 10 seconds after closing all the doors and the boot lid.

If a door or the boot lid remains open, the lights go out 60 seconds after switching off the ignition.

The function Coming Home is controlled with the light sensor in the mount of the interior rear mirror. If the light intensity is higher than the set value of the light sensor, the Coming Home Function is not switched on after switching off the ignition.

**Note**

- If the Coming Home Function is switched on constantly, the battery will be heavily discharged particularly in short-haul traffic.
- The switching on of the described lights should only be undertaken in accordance with the legal requirements.
- You can change the illumination period for the Leaving Home Function by means of the Information display. ■

Leaving Home Function

This function makes it possible to switch on the lights when approaching the vehicle.

Switching on Leaving Home Function

- The light switch is in the position automatic driving lamp control **AUTO**.
- Unlock the vehicle with the radio remote control - the lights come on.

Depending on equipment fitted the function Leaving Home switches on the following lights:

- Parking lights,
- Low beam,
- Entry lighting in the exterior mirrors,
- Licence plate light.

Leaving Home Function

The function Leaving Home is controlled with the light sensor in the mount of the interior rear mirror. If the light intensity is higher than the set value of the light sensor, the Leaving Home Function is not switched on after unlocking the vehicle with the radio remote control.

After unlocking the vehicle with the radio remote control, the lights come on for 10 seconds. The Leaving Home Function is also switched off after the ignition is switched on and after locking the vehicle.

If no door is opened within 30 seconds, the lights go out and the vehicle is locked automatically.

Note

- If the Leaving Home Function is switched on constantly, the battery will be heavily discharged particularly in short-haul traffic.
- The switching on of the described lights should only be undertaken in accordance with the legal requirements.
- You can change the illumination period for the Leaving Home Function by means of the Information display. ■

Tourist light

This mode makes it possible to drive in countries with opposing traffic system, driving on the left/right, without dazzling the oncoming vehicles. When the mode "tourist light" is active, the side to side swivel of the headlights is deactivated.

The mode "tourist light" is activated/deactivated via the Information display in the menu:



- **Settings**
- **Lights & Vision**
 - **Travel mode**
 - Off
 - Switched on ■

Fog lights



Fig. 39 Dash panel: Light switch

Switch on the front fog lamp

- First of all turn the light switch into position  or  => fig. 39.
- Pull the light switch into position .

The warning light  lights up in the instrument cluster when the fog lights are switched on => page 26. ■

Fog lights with the function "CORNER"

The fog lights with the function "CORNER" are designed for a better illumination of the surrounding area near the vehicle when cornering, parking etc.

The fog lights with the function "CORNER" are adjusted according to the steering angle or after switching on the turn signal light⁷⁾ in the following circumstances:

- the vehicle is stationary and the engine is running or it moves with a speed of maximum 40 km/h;
- the daylight driving lights are not switched on;
- the low beam is switched on or the light switch is in the position **AUTO** and the intensity of the ambient light causes the low beam to be switched on;
- the fog lights are not switched on;
- no reverse gear is engaged.







Note

If you engage the reverse gear during the active function "CORNER", both fog lights illuminate. ■

Rear fog light

Switching on the rear fog light

- First of all turn the light switch into position  or  ⇒ page 51, fig. 39.
- Pull the switch into position .

The warning light  lights up in the instrument cluster when the rear fog light is switched on ⇒ page 26.

Only the rear fog light of the trailer lights up if the vehicle has a **factory-fitted towing device** or a **towing device from Škoda original accessories** and when you are towing a trailer which is fitted with the rear fog light.

The rear fog light is located in the rear light array on the driver's side.



Caution

The rear fog light should only be switched on if visibility is particularly poor (conform with any varying legal provisions) to avoid dazzling vehicles behind your vehicle. ■

Instrument lighting

You can adjust the brightness of the instrument lighting.



Fig. 40 Dash panel: Instrument lighting

Instrument lighting

- Switch on the light.
- Turn the control dial ⇒ fig. 40 to the desired intensity of the instrument lighting.

The illumination intensity of the Information display ⇒ page 22 is set automatically. It is only possible to adjust the instrument lighting with the control dial if the light intensity drops below the set value of the light sensor. ■

⁷⁾ If both switch on versions are conflicting, for example if the steering wheel is turned to the left and the right turn signal light is switched on, the turn signal light has the higher priority.

Headlamp range adjustment

Once the low beam is switched on you can then adapt the range of the headlights to the load of the vehicle.







Fig. 41 Dash panel: Lights and Visibility

- Turn the control dial \Rightarrow fig. 41 until you have adjusted the low beam so that oncoming traffic is not dazzled.

Settings

The positions correspond approximately to the following vehicle loads:

-  Front seats occupied, luggage compartment empty.
-  All seats occupied, luggage compartment empty.
-  All seats occupied, luggage compartment laden.
-  Driver seat occupied, luggage compartment laden.

Caution

Headlamp range adjustment should always be adjusted in a way that:

- it does not dazzle other road users, especially oncoming traffic,
- and the range is sufficient for safe driving.

Note

Headlights fitted with Xenon bulbs adapt automatically to the load and driving state of the vehicle (e.g. accelerating, braking) when the ignition is switched on and when driving. Vehicles which are equipped with Xenon bulbs do not have a manual headlight range adjustment control. ■

Switch for hazard warning lights



Fig. 42 Dash panel: Switch for hazard warning lights

- Press switch  \Rightarrow fig. 42 to switch the hazard warning light system on or off.

All the turn signal lights on the vehicle flash at the same time when the hazard warning light system is switched on. The indicator light for the turn signals and the indicator light in the switch also flash at the same time. You can also switch on the hazard warning light system if the ignition is switched off.

The hazard warning light system is switched on automatically if an airbag is deployed in the event of an accident.

Please comply with any legal requirements when using the hazard warning light system.

Note

Switch on the hazard warning light system if, for example:

- you encounter traffic congestion;
- your vehicle breaks down or an emergency situation occurs. ■

The turn signal and main beam lever

The parking lights and headlight flasher are also switched on and off using the turn signal and main beam lever.

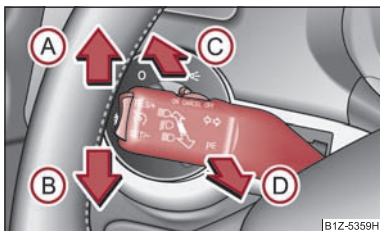







Fig. 43 Turn signal and main beam lever

The turn signal and main beam lever perform the following functions:



Right and left turn signal light

- Push the lever upwards  or downwards  ⇒ fig. 43 .
- If you only wish to flash three times (the so-called convenience turn signal), push the lever briefly up to the upper or lower pressure point and release it. This function can be activated/deactivated in the Information display ⇒ page 22.
- Turn signal for changing lanes - in order to only flash briefly, move the lever up or down to the pressure point and hold it in this position.

Main beam

- Switch on the low beam.
- Push the lever forwards in direction of arrow  (spring-tensioned position).
- If you push the lever towards the steering wheel in direction of arrow  (spring-tensioned position) the main beam is switched off.



Headlight flasher

- Pull the lever towards the steering wheel (spring-tensioned position) in direction of arrow  - the main beam and warning light  in the instrument cluster come on.

Parking light

For a description of the operation, see ⇒ page 50, "Parking light".

Information concerning the function of the lights.

- The **turn signal system** only operates when the ignition is switched on. The corresponding warning light  or  in the instrument cluster also flashes.
- The turn signal is automatically cancelled after negotiating a curve.
- The indicator light flashes at twice its normal rate if a bulb of the turn signal light fails.

Caution

Use main beam or the headlight flasher only if this does not risk dazzling other road users.

Note

Use only in accordance with the legal requirements the described lighting and signal systems. ■

Interior lighting

Interior vehicle lighting - Variant 1

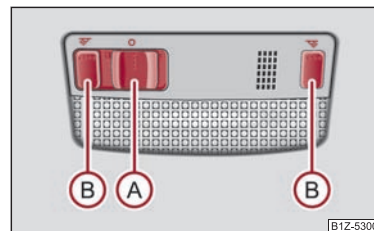



Fig. 44 Interior vehicle lighting - Variant 1

Switching on the interior lighting

- Press switch  towards the edge of the light, the symbol  ⇒ fig. 44 appears. ▶

Switching off the interior lighting

- Press the switch **A** into the middle position **O**.

Operating the lights with the door contact switch

- Press switch **A** towards the centre of the light, the symbol  appears.

Reading lights

- Press switch **B** to switch the reading light on/off.

If operating lights with the door contact switch is enabled (switch **A** is in position ) , the light will come on when:

- the vehicle is unlocked,
- one of the doors is opened,
- or the ignition key is removed.

If operating lights with the door contact switch is enabled (switch **A** is in position ) , the light will turn off when:

- the vehicle is locked,
- the ignition is switched on,
- about 30 seconds after all the doors have been closed.

If a door remains open, or if switch **A** is in position  the interior lighting goes out after 10 minutes to prevent the battery from discharging



Note

We recommend having these bulbs replaced by a specialist garage. ■

Interior vehicle lighting - Variant 2



Fig. 45 Interior vehicle lighting - Variant 2

Switching on the interior lighting

- Turn the switch to the position  ⇒ fig. 45.

Switching off the interior lighting

- Turn the switch to the position **O** .

Operating the lights with the door contact switch

- Turn the switch to the position .

The same principles apply for interior lighting version 2 as for ⇒ page 55. ■

Lighting of the storage compartment on front passenger side

- When opening the flap of the storage compartment on the front passenger side the lighting in the storage compartment comes on.
- The light switches on automatically when the parking light is switched on and goes out when the flap is closed. ■

Front door warning light



Fig. 46 Front door: Warning light

The warning light is located in the door trim panel below ⇒ fig. 46.

The warning light goes on every time the door is opened. The light goes out about 10 minutes after opening the door in order to avoid discharging the battery of the vehicle.

There is a reflector installed on some vehicles instead of the warning light. ■

Entry lighting

The lighting is positioned on the bottom edge of the exterior mirror.

The light beam is directed towards the entry area of the front door.

The light comes on after the doors have been locked or on opening the boot lid. The light goes out after switching on the ignition or up to 30 seconds after closing all the doors and the boot lid.

If a door or the boot lid remains open, the light goes out within 2 minutes if the ignition is switched off.



WARNING

If the entry light comes on, do not touch its cover - risk of burns! ■

Luggage compartment light

The lighting comes on automatically when the boot lid is opened. If the lid remains open for more than about 10 minutes, the luggage compartment lighting switches off automatically. ■

Visibility

Rear window heater



Fig. 47 Switch for rear window heater

- You can switch the rear window heater on or off by pressing the switch  ⇒ fig. 47 - the indicator light in the switch comes on or goes out.

The rear window heater only operates when the engine is running.

The rear window heater **switches off** automatically after 10 minutes.



For the sake of the environment

As soon as the window is de-iced or free from mist, the heating should be switched off. The reduced current consumption will have a favourable effect on fuel economy ⇒ page 172, "Saving electricity".



Note

- If the on-board voltage drops, the rear window heater switches off automatically, in order to provide sufficient electrical energy for the engine control.
- The position and the shape of the switch can differ depending on equipment installed in the vehicle. ■

Sun visors

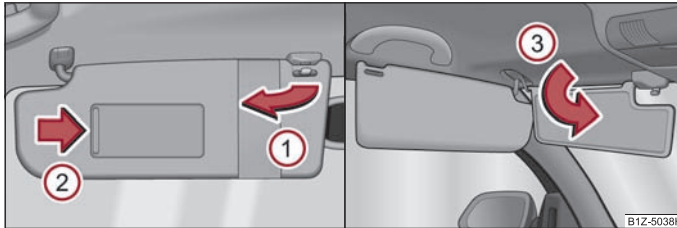

Fig. 48 Sun visor: Swivelling out/double sun visor

You can pull the sun visor for the driver or front passenger out of the fixture and swivel it toward the door in the direction of the arrow (1) ⇒ fig. 48.

The vanity mirrors in the sun visors are provided with covers. Push the cover in direction of arrow (2).

On vehicles which are equipped with double sun visor, you can also unfold the auxiliary visor in direction of arrow (3) after swivelling the sun visor.

WARNING

The sun visors must not be swivelled to the side windows into the deployment area of the head airbags if any objects, such as ball-point pens etc. are attached to them. This might result in injuries to the occupants if the head airbag is deployed. ■

Sun screen

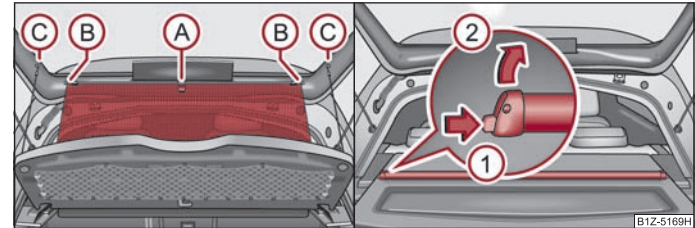

Fig. 49 Unroll/remove the sun screen

The sun screen is located in a housing on the luggage compartment cover. If required, you can remove the housing with the sun screen from the luggage compartment cover.

Pulling out

- Pull the sun screen at the loop (A) and hang it in the brackets (B) ⇒ fig. 49.

Folding

- Take the sun screen out of the brackets (B) and hold it at the loop (A) so that it can roll up slowly and without damage into the housing on the luggage compartment cover.

Removing

- Unhook the fastening elements from the luggage compartment cover (C).
- Roll up the sun screen again into the housing on the luggage compartment cover.
- Press the locking button in the direction of arrow (1) and take out the sun screen in the direction of arrow (2). ■

Windshield wiper and wash system

Windshield wiper

You can operate the windshield wipers and automatic wipe/wash using the windshield wiper lever.



Fig. 50 Windscreen wiper lever

The windshield wiper lever ⇒ fig. 50 has the following positions:

Finger-operated wiping

- If you wish to wipe the windshield only **briefly**, push the lever into the sprung position ④. If you hold the lever in the lower position for more than 1 second, the wiper wipes faster.

Intermittent wiping

- Position the lever up into position ①.
- Set with the switch (A) the desired break between the individual wiper strokes.

Slow wipe

- Position the lever up into position ②.

Fast wipe

- Position the lever up into position ③.

Automatic wipe/wash for windshield

- Pull the lever towards the steering wheel into sprung position ⑤, the wash system sprays immediately, the windshield wiper starts wiping a little later. The wash system and the windshield wiper operate simultaneously at a speed of more than 120 km/h.
- Release the lever. The windshield wash system stops and the wiper continues for another 3 - 4 wiper strokes (depending on the period of spraying of the windshield). At a speed of more than 2 km/h, the wiper wipes once again 5 seconds after the last wiper stroke in order to wipe the last drops from the windshield. This function can be activated/deactivated by a specialist garage.

Rain sensor

- Move the lever into position ①.
- You can set the sensitivity of the sensor individually with switch (A).

Wiping the rear window pane

- Push the lever away from the steering wheel into position ⑥- the windshield wiper will operate every 6 seconds.

Automatic wipe/wash for the rear window pane

- Press the lever from the steering wheel forward into the sprung position ⑦, the wash system sprays immediately, the windshield wiper starts wiping a little later. As long as you hold the lever in this position, the wiper operates as well as the wash system.
- Letting go of the lever will cause the windshield wash system to stop and the wiper to continue for another 2 - 3 wiper strokes (depending on the period of spraying of the windshield). **The lever will stay in position after releasing it ⑥.**

Switching windshield wipers off

- Move the lever back into its home position ①.

After the windshield wiper switches off each time or the ignition switches off for the third time, the position of the windshield wiper changes, this counteracts an early fatigue of the wiper rubbers.

The windshield wipers and the wash system only operate if the ignition is switched on and the bonnet is closed^{B)}.

^{B)} On vehicles which do not have a contact switch for the bonnet, the windshield wiper and wash system operates also when the bonnet is opened.

If the intermittent wipe is switched on, the intervals are also controlled depending on speed.

The rain sensor automatically regulates the break between the individual wiper strokes depending on the intensity of the rain.

The rear window will be wiped again if the front window wipers are on when reverse gear is selected.

Top up with wash liquid ⇒ page 197.

Winter position

If the windscreen wipers are in rest position, they cannot be folded out from the windscreen. For this reason we recommend adjusting the windscreen wipers in winter so that they can be folded out from the windscreen easily. You can set this rest position as follows:

- Switch on the windscreen wipers.
- Switch off the ignition. The windscreen wipers remain in the position in which they were when switching off the ignition.

You can also use the service position ⇒ page 60 as a winter position.



WARNING

- Properly maintained windscreen wiper blades are essential for clear visibility and safe driving ⇒ page 60.
- Do not use the windscreen washer system at low temperatures, without heating the windscreen beforehand. Otherwise the window cleaner could freeze on the windscreen and restrict the view to the front.
- The rain sensor only operates as a support. The driver is not released from the responsibility to set the function of the windscreen wipers manually depending on the visibility conditions.

Caution

In frosty weather, please first of all check whether the windscreen wiper blades are not frozen to the windscreen before switching them on. Switching on windscreen wipers when the blades are frozen to the windscreen may result in damage both to the blades and the motor of the windscreen wipers!



Note

• If the slower  or the faster  wiper setting is switched on ⇒ page 58, fig. 50 and the vehicle speed decreases to below 4 km/h, the lower wiper step is switched

on automatically. At a speed increase of more than 8 km/h the previous wiper setting is established again.

- If there is an obstacle on the windscreen, the wiper will try to push away the obstacle. If the obstacle continues to block the wiper, the wiper stops automatically after 5 attempts to eliminate the obstacle, in order to avoid a damage to the wiper. Remove the obstacle and and switch on the wiper again.
- The windscreen washer nozzles for the windscreen are heated when the engine is running and the outside temperature is less than +10 °C.
- The content of the windscreen wiper reservoir is 3 litres. On vehicles which are equipped with a headlight cleaning system, the content of the reservoir is 5.5 litres. On vehicles fitted with auxiliary heating, the content of the windscreen wiper reservoir is 4.5 litres. ■

Automatic rear window wiper (Estate car)

If the windshield wiper is in positions  ⇒ page 58, fig. 50 or  the rear view window is wiped every 30/10 seconds if the vehicle's speed exceeds 5 km/h.

When the rain sensor is active (the lever is in the position ) the function is only active if the front window wipers continue to operate (no break between each wiping process).

Activation/deactivation

The function of the automatic rear window wiper is activated/deactivated in the information display in the menu:

- Settings
 - Lights & Vision
 - Rear wiper

Note

The function of the automatic rear window wiper is only valid for Estate car vehicles which are equipped with an information display. The function is activated in the factory. ■

Headlight cleaning system

The headlights are being cleaned after the windscreen has been sprayed for the first time and fifth time, the low beam or main beam are switched on and the windscreen wiper lever was held in the position  ⇒ page 58, fig. 50 for about 1 second. ▶

The headlight washer nozzles are moved forward out of the bumper by the water pressure for cleaning the headlights.

You should remove stubborn dirt (such as insect residues) from the headlight lenses at regular intervals, for example when refuelling. Please refer to the following guidelines ⇒ page 179, "The headlight lenses".

You should remove any snow from the fixtures of the washer nozzles and clear ice in winter with a de-icing spray in order to ensure proper operation of the cleaning system.

! Caution

Never remove the nozzles from the headlamp cleaning system by hand - risk of damage! ■

Replacing wiper blades for the windscreen wipers

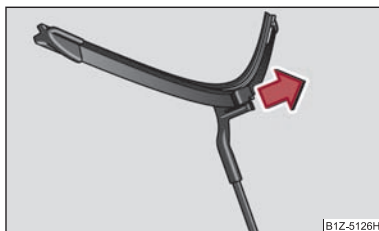

Fig. 51 Wiper blade for the windscreen wiper

One cannot fold out the wiper arms in the rest position from the windscreen. Before replacing the wiper arms you must put them into the service position.

Service position for changing wiper blades

- Close the bonnet.
- Switch the ignition on and then again off.
- Then press the windscreen wiper lever in the position ④ ⇒ page 58, fig. 50 within 20 seconds - the wiper arms move into the service position.

Removing the wiper blade

- Fold windscreen wiper arm out from the windscreen and position the wiper blade at right angles to the wiper arm ⇒ ⚠.

- Take off the wiper blade in direction of arrow ⇒ fig. 51 ⇒ ⚠.

Attaching the wiper blade

- Push the new wiper blade over the wiper arm and turn the wiper blade into the vertical position.
- Check whether the wiper blade is correctly attached.
- Fold the windscreen wiper arms onto the window and switch on the ignition. By pressing the window wiper lever into the sprung position ④ ⇒ fig. 51 or when driving at a speed greater than 4 km/h, the windscreen wiper arms move back into the rest position.

Windscreen wiper blades in proper condition are essential to obtain good visibility. Wiper blades should not be allowed to become dirtied by dust, insect remains and preserving wax.

Juddering or smearing of the wiper blades could then be due to wax residues left on the windscreen by vehicle washing in automatic vehicle wash systems. It is therefore important to **degrease** the lips of the windscreen wiper blades after every pass through an **automatic vehicle wash system**.



WARNING

- The ignition must not be switched on if the front windscreen wiper arms are folded out. The wiper blades would move back into their rest position and while doing so damage the paintwork of the bonnet.
- If the windscreen wipers are handled carelessly, there is a risk of damage to the windscreen.
- You should clean the wiper blades regularly with a windscreen cleaner in order to avoid any smears. Clean a wiper blade with a sponge or cloth if it is very dirty, for example from insect residues.
- Replace the windscreen wiper blades once or twice a year for safety reasons. These can be bought from an authorised Skoda Service Partner. ■

Replacing the wiper blade on the rear window wiper

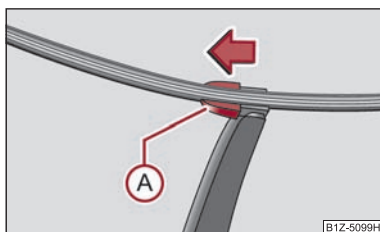

Fig. 52 Wiper blade for the rear window

Removing the wiper blade

- Fold windscreen wiper arm out from the windscreen and position the wiper blade at right angles to the wiper arm ⇒ fig. 52.
- Hold the window wiper arm at the top end with one hand.
- With the other hand unlock the locking button (A) in the direction of arrow and remove the wiper blade.

Attaching the wiper blade

- Position the wiper blade onto the wiper arm and lock the locking button (A).
- Check whether the wiper blade is correctly attached.
- Fold the windscreen wiper arm back onto the windscreen.

The same remarks apply here as for ⇒ page 60. ■

Rear-view mirror

Manual dimming interior rear-view mirror

Basic setting

- Pull the lever on the bottom edge of the mirror forward.

Dimming mirror

- Pull the lever on the bottom edge of the mirror back. ■

Automatic dimming interior mirror

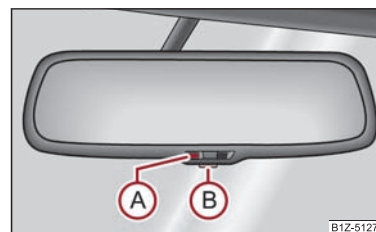

Fig. 53 Automatic dimming interior mirror

Switching on the automatic dimming

- Press the button (B) ⇒ fig. 53, the warning light (A) lights up.

Switching off the automatic dimming

- Press again the button (B) - the warning light goes out (A).

If the automatic dimming is switched on, the mirror dims **automatically** depending on the light striking the mirror from the rear. The mirror has no lever on the bottom edge of the mirror. After the reverse gear is engaged, the mirror always moves back into the normal position.

Note

- Automatic mirror dimming operates only properly if the sun screen for the rear window in the housing on the luggage compartment cover is not in use or the light striking the interior rear-view mirror is not affected by other objects.
- Do not affix any stickers in front of the light sensor, so that you do not impair the automatic dimming function or put it out of operation.
- If you switch off the automatic dimming interior rear-view mirror, also the exterior mirror dimming is switched off. ■

Exterior mirror

You can adjust the exterior mirrors electrically.

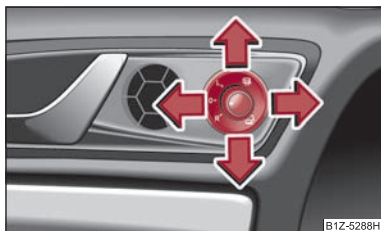

Fig. 54 Inner part of door: Rotary knob

Adjust the rear mirror before commencing to drive so that there is a clear view to the rear.

Heating of the external mirror

- Turn the rotary knob to position ⇒ fig. 54.

The exterior mirror heater only operates when the engine is running and up to an outside temperature of +20 °C.

Adjusting left and right exterior mirrors simultaneously

- Turn the rotary knob to position **L**. The movement of the mirror surface is identical to the movement of the rotary knob.

The adjustment of both mirrors simultaneously or each individual mirror is possible in the Information display ⇒ page 24 in the menu point **Mirror adjust**.

Adjusting the right-hand exterior mirror

- Turn the rotary knob to position **R**. The movement of the mirror surface is identical to the movement of the rotary knob.

Switching off operating control

- Turn the rotary knob to position **0**.

Folding in both exterior mirrors

- Turn the rotary knob to position .

Folding exterior mirrors using the key with radio remote control

- If all the windows are closed, press the unlock button on the radio remote control ⇒ page 41, fig. 31 for approx. 2 seconds.

Tilting surface of front passenger exterior mirror

On vehicles fitted with a memory for the driver seat, the surface of the mirror tilts down slightly when the rear gear is engaged and the rotary knob is in the position **R** ⇒ fig. 54. This provides an aid in seeing the kerb of the pavement when parking the car.

The mirror returns into its initial position, after the rotary knob is moved out of the position **R** and put into another position or if the speed is more than 15 km/h.

Memory for exterior mirrors

On vehicles fitted with a memory for the driver seat, the relevant setting of the exterior mirror is also stored automatically when the seat position is stored ⇒ page 65.

WARNING

- Convex (curved outward) or a spherical exterior mirrors increase the vision field. They do, however, make objects appear smaller in the mirror. These mirrors are only of limited use, therefore, for estimating distances to the following vehicles.**
- Use whenever possible the interior rear mirror, for estimating the distances to the following vehicles.**

Note

- If the exterior mirrors are folded in using the remote control of the vehicle key, these are folded back into the driving position after opening the door or switching on the ignition.
- If the exterior mirrors are folded in using the rotary knob ⇒ fig. 54, they can only be folded back into the driving position using the rotary knob.
- If the exterior mirrors were folded in using the remote control of the vehicle key and if the rotary knob was in the fold-in position before switching on the ignition, the mirrors remain in the fold-in position the next time the ignition is switched on. Folding back into the driving position is performed by actuating the rotary knob in a different position from the fold-in position.
- Do not touch the surfaces of the exterior mirrors if the exterior mirror heater is switched on.

- You can set the exterior mirrors by hand, if the power setting function fails at any time, by pressing on the edge of the mirror surface.
- Contact your specialist garage if a fault exists with the power setting of the exterior mirrors. ■

Automatic dimming exterior mirror on the driver's side

The exterior mirror on the driver's side is dimmed together with the interior mirror. If the automatic dimming is switched on, the mirror dims **automatically** depending on the light striking the mirror from the rear.

After the reverse gear is engaged, the mirror always moves back into the normal (not dimmed) position.



Note

- Automatic mirror dimming operates only properly if the sun screen for the rear window is not in use or the light striking the rear of the interior rear-view mirror is not affected by other objects.
- Do not affix any stickers in front of the light sensor, so that you do not impair the automatic dimming function or put it out of operation.
- If you switch off the automatic dimming interior rear-view mirror, also the exterior mirror dimming is switched off. ■

Seats and Stowage

Front seats

Basic information

The front seats have a wide range of different settings and can thus be matched to the physical characteristics of the driver and front passenger. Correct adjustment of the seats is particularly important for:

- safely and quickly reaching the controls,
- a relaxed, fatigue-free body position,
- achieving the maximum protection offered by the seat belts and the airbag system.

! WARNING

- Never transport more occupants than the maximum seating in the vehicle.
- Each occupant must correctly fasten the seat belt belonging to the seat. Children must be fastened ⇒ page 153, "Transporting children safely" with a suitable restraint system.
- The front seats and the head restraints must always be adjusted to match the body size of the seat occupant as well as the seat belts must always be correctly fastened in order to provide an optimal protection for you and your occupants.
- Always keep your feet in the footwell when the car is being driven - never place your feet on the instrument panel, out of the window or on the surfaces of the seats. This is particularly important for the front seat passenger. You will be exposed to increased risk of injury if it becomes necessary to apply the brake or in the event of an accident. If an airbag is deployed, you may suffer fatal injuries when adopting an incorrect seated position!
- It is important for the driver and front passenger to maintain a distance of at least 25 cm from the steering wheel or dash panel. Not maintaining this minimum distance will mean that the airbag system will not be able to properly protect you - hazard! The front seats and the head restraints must always also be correctly adjusted to match the body size of the occupant.
- Ensure that there are no objects in the footwell as any objects may get behind the pedals during a driving or braking manoeuvre. You would then no longer be able to operate the clutch, to brake or accelerate.

! WARNING (continued)

- Do not transport any objects on the front passenger seat except those provided for this purpose (e.g. child safety seat) - risk of accident! ■

Adjusting the front seats



Fig. 55 Controls at seat

Adjusting a seat in a forward/back direction

- Pull the lever ① ⇒ fig. 55 up and push the seat into the desired position.
- Release the lever ① and push the seat further until the lock is heard to engage.

Adjusting height of seat

- Lift the seat if required by pulling or pumping lever ② upwards.
- Lower the seat if required by pushing or pumping lever ② downwards.

Adjust the angle of the seat backrest

- Relieve any pressure on the seat backrest (do not lean on it) and turn the hand-wheel ③ to adjust the angle of the backrest.

Adjusting lumbar support

- Turn the wheel ④ until you have set the most comfortable curvature of the seat upholstery in the area of your spine. ▶

The driver's seat should be adjusted in such a way that the pedals can be fully pressed to the floor with slightly bent legs.

The seat backrest on the driver's seat should be adjusted in such a way that the upper point of the steering wheel can be easily reached with slightly bent arms.

⚠ WARNING

- Only adjust the driver seat when the vehicle is stationary - risk of injury!
- Take care when adjusting the seat! Adjusting the seat without care can lead to bruises or injuries.
- The seat backrests must not be angled too far back when driving otherwise this will affect proper operation of the seat belts and of the airbag system - risk of injury! ■

Adjusting front seats electrically

Adjusting seats

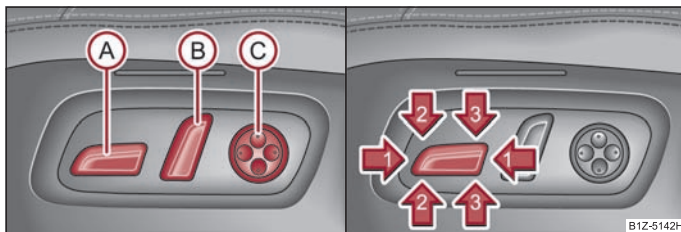

Fig. 56 Side view: Controls for adjusting the seat/seat setting switch

Adopt the correct seated position before setting ⇒ page 64.

Adjusting a seat in a forward/back direction

- Press the switch **(A)** ⇒ fig. 56 forwards or backwards **(1)**.

Set the height of the seat cushion

- Press the switch **(A)** upwards or downwards.

Adjust the angle of the seat cushion

- Press the switch **(A)** at the front in the direction of arrow **(2)** or at the back in the direction of arrow **(3)**.

Adjusting the seat backrest

- Press the switch **(B)** in the direction of the desired setting.

Adjusting lumbar support

- Press the switch **(C)** at the front in order to enlarge the curvature of the lumbar support.
- Press the switch **(C)** rear in order to reduce the curvature of the lumbar support.
- Press the switch **(C)** top in order to adjust the curvature of the lumbar support higher.
- Press the switch **(C)** bottom in order to adjust the curvature of the lumbar support lower.

Switch **(A)** is operated in order to move the seat up/down and forward/back, while switch **(B)** is operated in order to move the seat backrest forward or back.

⚠ WARNING

- Only adjust the driver seat when the vehicle is stationary - risk of injury!
- Caution when adjusting the seat! You may suffer injuries or bruises as a result of adjusting the seat without paying proper attention.
- In view of the fact that the seats can also be adjusted when the ignition is switched off (even when ignition key withdrawn), you should never leave children unattended in the car.
- The seat backrests must not be angled too far back when driving otherwise this will affect proper operation of the seat belts and of the airbag system - risk of injury!

i Note

If the movement of the seat is inadvertently interrupted during an adjustment, once again press the switch in the appropriate direction and continue with the adjustment of the seat to the end. ■

Storing setting

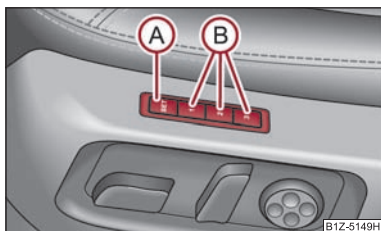

Fig. 57 Driver seat: Memory buttons and SET button

Storing seat and exterior mirror settings for driving forward

- Switch on the ignition.
- Adjust the seat ⇒ page 65.
- Adjust both exterior mirrors ⇒ page 62.
- Press button **SET** (A) ⇒ fig. 57.
- Press one of the memory buttons (B) within 10 seconds after pressing the button **SET** - an acknowledgement signal confirms that the seat setting is stored.

Storing exterior mirror setting for reversing

- Switch on the ignition.
- Turn the exterior mirror control to position **R** ⇒ page 62.
- Engage reverse gear.
- Move the right exterior mirror into the desired position ⇒ page 62.
- Take the vehicle out of gear. The set position of the exterior mirror is stored.

Memory buttons

Memory for the seat offers the possibility to store the individual driver seat and external mirror position. An individual position can be allocated to each of the three memory buttons (B) ⇒ fig. 57, that is three in total. After pressing the corresponding memory button (B), the seat and the exterior mirror are automatically moved into the positions which have been allocated to this button ⇒ page 66.

Emergency Off

You can interrupt the setting operation at any time, if you operate any button of the driver seat.

i Note

- When storing settings with the memory buttons, we recommend that you begin with the front button and assign a memory button to each additional driver.
- Each new setting stored with the same button erases the previous setting.
- Each time you store the seat and exterior mirror settings for driving forward you also have to re-store the individual setting of the exterior mirror on the passenger side for reversing. ■

Assigning the remote control key to the memory buttons

After storing the settings of the seat and exterior mirrors, you have 10 seconds in order to assign the remote control to the appropriate memory button.

- Withdraw the ignition key.
- Press the unlock button ⇒ page 41, after the successful assignment an audible signal will sound. The setting is stored with the memory button which you have selected.

If you wish to be able to retrieve the settings which are stored in the memory by also using the remote control, you have to assign the remote control to a memory button in each case.

If you wish, you can obtain an additional remote control key from an authorised Škoda Service partner and then assign the remote control key to another memory button.

i Note

- If the remote control had previously been assigned to another memory button, this setting is then erased by the new assignment.
- If you assign the remote control to a memory button which has already been assigned to a remote control, the old assignment is also replaced by a new assignment in this case.
- The assignment of the radio remote control to a memory button is retained, however, after reassigning the seats and exterior mirrors. ▶

- After the successful assignment, the turn signal lights flash and an audible signal will sound as a confirmation. The setting is stored with the memory button which you have selected. ■

Retrieving settings of the seat and mirrors

You can retrieve the stored settings either with the memory buttons or with the remote control.

Retrieving settings with memory buttons

- In order to retrieve the stored setting, you have two possibilities:
- **One-touch automatic memory:** briefly press the desired memory button (B) ⇒ page 66, fig. 57. The seat and exterior mirror are moved automatically into the stored positions (this applies only if the ignition is switched on and the speed is less than 5 km/h).
- **Memory keying:** Press and hold the desired memory button (B) pressed long enough until the seat and the exterior mirror are moved into the stored positions.

Retrieving settings with remote control

- If the driver door is closed and the ignition is switched off, briefly press the unlock button of the remote control ⇒ page 41 and then open the driver door.
- The seat and exterior mirrors now move automatically into the stored positions.

Retrieving setting of exterior mirror for reversing

- Turn the rotary knob for the exterior mirror setting into the position R ⇒ page 62 before engaging the reverse gear.

The mirror returns into its initial position, after the rotary knob is moved out of the position R and put into another position or if the speed is more than 15 km/h.

Emergency Off

You can interrupt the setting operation at any time, if you operate any button of the driver seat.

Note

If the inclination angle of the seat backrest is more than 102° in relation to the seat cushion, the backrest remains in this position, after reaching this angle, when retrieving the setting by briefly pressing the memory button. Once the stored angle

is reached, it is necessary to press the memory button and hold it pressed until the seat is in the stored position. ■

Head restraints

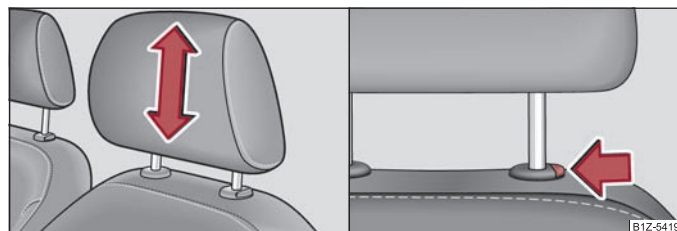

Fig. 58 Head restraint: Adjusting/pulling out

Best protection is achieved if the top edge of the head restraint is at the same level as the upper part of your head.

Adjusting the height of a head restraint

- Grasp the side of the head restraint with both hands and push it in upward direction as desired ⇒ fig. 58 - left.
- Move the head restraint downwards if required by pressing and holding the safety button with one hand ⇒ fig. 58 - right and by pressing with the other hand the head restraint downwards.

Removing and installing a head restraint

- Pull the head restraint up out of the seat backrest as far as the stop (on the rear head restraints fold forward the seat backrest).
- Press the locking button in the direction of arrow ⇒ fig. 58 - right and pull the head restraint out.
- To re-insert the head restraint, push it down into the seat backrest far enough until you hear the locking button engage.

The position of the front and rear outer head restraints is adjustable in height. The middle rear head restraint is adjustable in two positions. ►

The head restraints must be adjusted to match the size of the seat occupant. Correctly adjusted head restraints together with the seat belts offer effective protection for the occupants ⇒ page 138, "Correct seated position".

⚠ WARNING

- The head restraints must be correctly adjusted in order to offer effective protection for the occupants in the event of an accident.
- Do not drive under any circumstance with removed head restraints - risk of injury!
- If the rear seats are occupied, the rear head restraint must not be in the lower position. ■

Middle rear head restraint

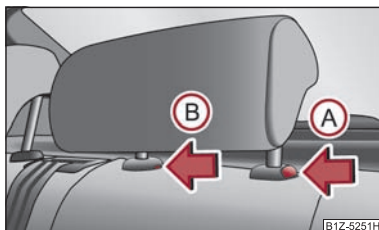

Fig. 59 Rear seats: middle head restraint

In certain countries national legal provisions also require the equipment of the rear seat with fixing eyes for child seat using the "Top Tether" system ⇒ page 158, "Attaching child seat using the "Top Tether" system". For vehicles, which are equipped with such fixing eyes, a deviating sequence for removing the middle head restraint must be observed.

Removing and installing the rear middle head restraint

- Pull the head restraint out of the seat backrest as far as the stop.
- Press the locking button in the direction of arrow (A), press simultaneously the locking button into the opening (B) using a flat screwdriver with a width of maximum 5 mm and pull out the head restraint.
- To re-insert the head restraint, push it down into the seat backrest far enough until you hear the locking button engage.

⚠ WARNING

- The head restraints must be correctly adjusted in order to offer effective protection for the occupants in the event of an accident.
- Do not drive under any circumstance with removed head restraints - risk of injury!
- If the rear seats are occupied, the rear head restraint must not be in the lower position. ■

Rear seats

Folding the rear seats forwards

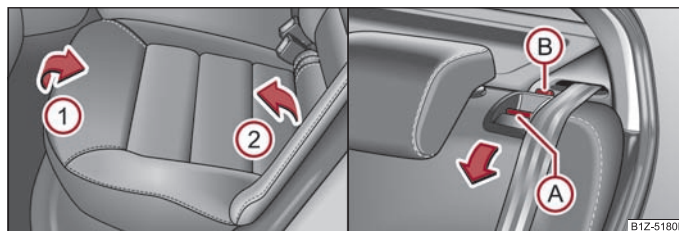

Fig. 60 Fold the seat cushion forwards/unlock the seat backrest

To enlarge the luggage compartment, the rear seats can be folded forwards, if necessary remove the seat cushions. The rear seats can be folded forward individually on vehicles with divided rear seats.

Folding seats forwards

- Before folding the rear seats forwards, you must adapt the position of the front seats in such a way that they are not damaged when the rear seats are folded forwards.
- Pull up the seat cushion in direction of arrow (1) and fold forwards in direction of arrow (2) ⇒ fig. 60.
- Press the unlocking knob (A) and fold the seat backrest forwards. ▶

If the front seats are too far back, we recommend that you have the rear head restraints removed before the seat backrests are folded forward. Store the removed head restraints in such a way that they cannot be damaged or soiled. Please refer to the guidelines ⇒ page 71. ■

Move seats into the initial position

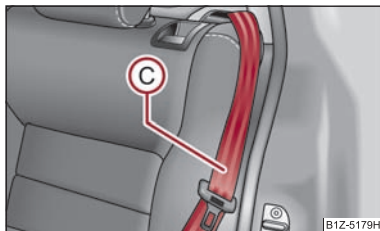

Fig. 61 Lock the seat backrest

Move seats into the initial position

- Install the head restraint in the slightly lifted seat backrest.
- Place the rear lateral seat belt (C) ⇒ fig. 61 behind the edge of the side trim panel.
- Then push the seat backrest back into the upright position until the securing knob clicks into place - check by pulling on the seat backrest.
- Make sure that the red pin (B) is covered ⇒ page 68, fig. 60.
- Move the seat cushion into its original position.

⚠ WARNING

- The belts and the belt locks must be in their original position after folding back the seat cushions and the seat backrests - they must be ready to use.
- The seat backrests must be securely interlocked in position so that no objects in the luggage compartment can slide forwards if there is sudden braking - risk of injury!
- Pay attention that the seat backrests are correctly interlocked. It is only then that the three-point seat belt for the middle seat can reliably fulfil its function.
- Before folding the seat backrest back into the secure position, place the rear lateral seat belt behind the edge of the side trim panel. Take suitable measures

⚠ WARNING (continued)

to prevent that the seat belt is jammed between the seat backrest and the side trim panel and is thus damaged. ■

Removing the seats

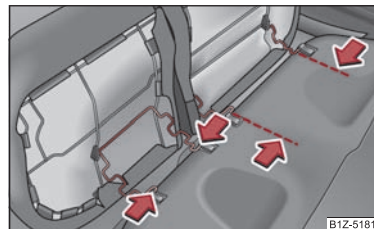

Fig. 62 Removing the seats

You can enlarge the luggage compartment on vehicles with divided rear seats by removing the rear seat.

Removing

- Fold the seat cushion forwards completely.
- Press the wire clamps in the direction of the arrow ⇒ fig. 62 and remove the seat cushion from its holder.

Installing

- Press the wire clamps in the direction of the arrow and place it in its holder.
- Fold the seat cushion back into its original position.

⚠ Caution

For vehicles with heated rear seats it is necessary to disconnect the plug connection for the power supply before removing the seat cushion. For reinstalling the seat cushion it is necessary to re-connect the plug connection. ■

Rear seat armrest

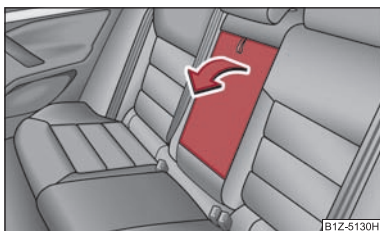

Fig. 63 Rear seats: Armrest

- You can fold down the armrest at the loop to enhance occupant comfort
⇒ fig. 63. ■

Seat heaters

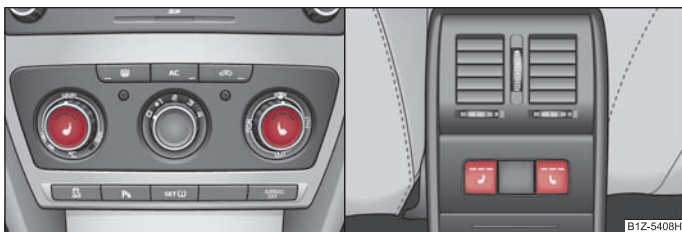

Fig. 64 Regulator for heating the front seats/rear seats

You can electrically heat the seat backrests and the surfaces of the front seats and the two outer rear seats.

- You can switch on and regulate the seat heating of the driver or front passenger seat by pressing the surface of the regulator at the point at which the symbol is located ➡ ⇒ fig. 64 - left.
- You can switch on and adjust the heaters of the left or right rear seats by pressing the regulator ➡ ⇒ fig. 64 - right.
- With one press, you can switch the heating to highest intensity - 3rd stage, which is indicated by the lighting up of the three warning lights in the switch.

- With repeated pressing of the switch, the intensity of the heating is down-regulated up to the switch-off. The intensity of the heating is indicated by the number of illuminated warning lights in the switch.
- If you set the heating of the rear seats to the highest intensity - 3rd stage, it is automatically switched over to the 2nd stage after 10 minutes (two warning lights light up in the switch).

⚠ WARNING

If, as an occupant, you have a subdued pain and/or temperature sensitivity, e.g. through medication, paralysis or because of chronic illness (e.g. diabetes), we recommend not to use the seat heating. This can lead to burns on the back, the posterior and the legs which are difficult to heal. If the seat heating is used, we recommend to make regular breaks in your journey when driving long distances, so that in specific cases as mentioned above the body can recuperate from the stress of the journey. Please consult your doctor, who can evaluate your specific condition.

⚠ Caution

- You should not kneel on the seats or otherwise apply pressure at specific points in order to avoid damaging the heating elements of the seat heaters.
- Do not use the seat heating if the seats are not occupied by persons or if objects are fastened or stored on them, for example a child seat, a bag etc. A fault of the heating elements in the seat heating can occur.
- Do not clean the seats moist ⇒ page 181.

ℹ Note

- The seat heating should only be switched on when the engine is running. This has a significant effect of saving on the battery capacity.
- If the on-board voltage drops, the seat heating is switched off automatically, in order to provide sufficient electrical energy for the engine control. ■

Pedals

Concerning a secure depressing of the pedal, you should use only footmats from the Skoda genuine accessories.

Operation of the pedals must not be hindered! ▶

 **WARNING**

- Greater pedal distances may be needed when there is a fault in the brake system.
- Do not place any footmats or other additional floor coverings in the area of the pedals in order to ensure that all the pedals can be fully depressed and are able to return unobstructed to their initial position - risk of accident!
- There must be no objects on the floor which could roll under the pedals. You would then no longer be able to apply the brakes, operate the clutch or accelerator - risk of accident! ■

Luggage compartment

Loading the luggage compartment

Please observe the following in the interest of having good handling characteristics of your vehicle:

- Distribute the items of luggage as evenly as possible.
- Place heavy objects as far forward as possible.
- Attach the items of luggage to the lashing eyes or the fixing net ⇒ page 72.

In the event of an accident, there is such a high kinetic energy which is produced by small and light objects that they can cause severe injuries. The magnitude of the kinetic energy depends on the speed at which the vehicle is travelling and on the weight of the object. The speed at which the vehicle is travelling is in this case the more significant factor.

Example: In the event of a frontal collision at a speed of 50 km/h, an unsecured object with a weight of 4.5 kg produces an energy, which corresponds to 20 times its own weight. This means that it results in a weight of approx. 90 kg. You can imagine the injuries that can occur, if this "bullet" is flying through the interior compartment and hits an occupant.

 **WARNING**

- Store the objects in the luggage compartment and attach them to the lashing eyes.
- Loose objects in the passenger compartment can be thrown forward during a sudden manoeuvre or in case of an accident and can injure the occupants or other oncoming traffic. This risk is still increased, if the objects which are flying

 **WARNING (continued)**

around are hit by a deployed airbag. In this case, the objects which are thrown back can injure the occupants - hazard.

- Please note that the handling properties of your vehicle may be affected when transporting heavy objects as a result of the displacement of the centre of gravity. The speed and style of driving must be adjusted accordingly.
- The items carried in the luggage compartment should be stored in such a way that no objects are able to slip forward if there are any sudden driving or braking manoeuvres undertaken - risk of injury!
- Never drive with the boot lid fully opened or slightly ajar otherwise exhaust gases may get into the interior of the vehicle - risk of poisoning!
- On no account exceed the permissible axle loads and the permissible gross weight of the vehicle - risk of accident!
- Never transport occupants in the luggage compartment!

 **Caution**

Make sure that transported objects with sharp edges do not damage the following:

- heating elements in the rear window,
- elements of the aerial integrated in the rear window (Octavia),
- elements of the aerial integrated in the rear side windows (Estate car).

 **Note**

Tyre pressure must be adjusted to the load ⇒ page 199. ■

Vehicles of category N1

On vehicles of the category N1, which are not fitted with a protective grille, a lashing set which complies with the standard EN 12195 (1 - 4) must be used for fastening the load. ■

Lashing eyes

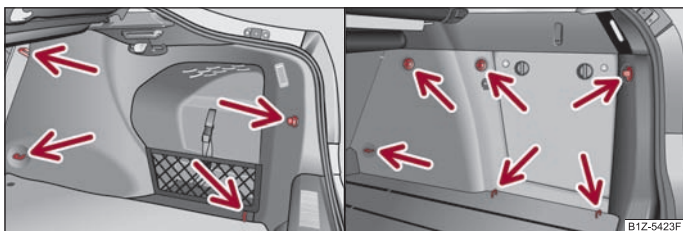

Fig. 65 Luggage compartment: Lashing eyes Octavia/Estate

Eyes are located on the sides of the luggage compartment for lashing the goods to be loaded.

You can also attach a floor fixing net to these eyes for holding small objects.

The floor fixing net and the installation instruction are located in a container under the floor covering of the luggage compartment behind the spare wheel.

WARNING

- The load to be transported must be fixed in place in such a way that it cannot move during the journey and when braking.
- If the items of luggage or objects are attached to the lashing eyes with unsuitable or damaged lashing straps, injuries can occur in the event of braking manoeuvres or accidents. In order to prevent the items of luggage being thrown forward, always use suitable lashing straps which are firmly attached to the lashing eyes.

Note

The upper front lashing eyes are located underneath the folding rear seat backrest ⇒ fig. 65. ■

Fixing nets - Net programme Octavia

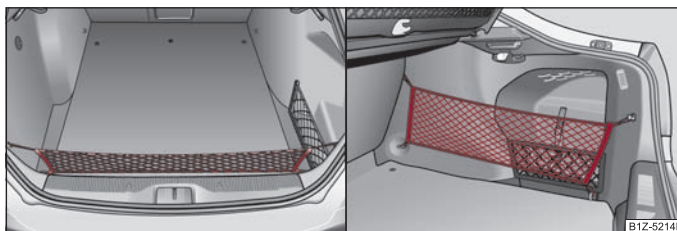

Fig. 66 Fixing net: Horizontal pocket/vertical pocket

Fixing examples of the fixing net as a horizontal pocket ⇒ fig. 66 - left and a vertical pocket ⇒ fig. 66 - right.

The fixing net is stowed in a storage compartment behind the spare wheel under the floor covering of the luggage compartment.

WARNING

- The whole strength of the net makes it possible to load the pocket with objects of up to 1.5 kg in weight. Heavy objects are not secured sufficiently - risk of injury and net damage!
- The load to be transported must be fixed in place in such a way that it cannot move during the journey and when braking.

Caution

Do not place any objects with sharp edges in the nets - risk of net damage. ■

Fixing nets - Net programme Estate

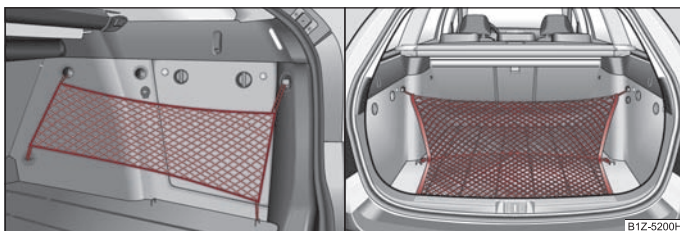

Fig. 67 Fixing net: Vertical pocket/division of the luggage compartment

Fixing examples of the fixing net as a horizontal pocket ⇒ fig. 67 - left and as a division of the luggage compartment with the aid of the net ⇒ fig. 67 - right.

The fixing net is stowed in a storage compartment behind the spare wheel under the floor covering of the luggage compartment.

WARNING

- The whole strength of the net makes it possible to load the pocket with objects of up to 1.5 kg in weight. Heavy objects are not secured sufficiently - risk of injury and net damage!
- The load to be transported must be fixed in place in such a way that it cannot move during the journey and when braking.

Caution

Do not place any objects with sharp edges in the nets - risk of net damage. ■

Folding double hooks (Octavia)

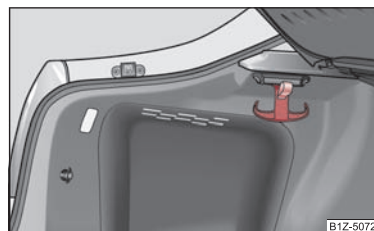

Fig. 68 Luggage compartment: Folding double hooks

Folding double hooks for attaching small items of luggage, such as bags etc. are provided on one or both sides of the luggage compartment depending on the equipment installed in the vehicle ⇒ fig. 68.

Caution

An item of luggage weighing up to 5 kg can be attached to each side of the double hook. ■

Folding hooks (Estate car)

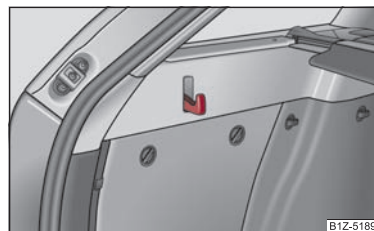

Fig. 69 Luggage compartment: folding hooks

Folding hooks for attaching small items of luggage, such as bags etc., are provided on both sides of the luggage compartment ⇒ fig. 69. ▶

⚠ Caution

An item of luggage weighing up to 7.5 kg can be attached to the hook. ■

Fixing floor covering of the luggage compartment

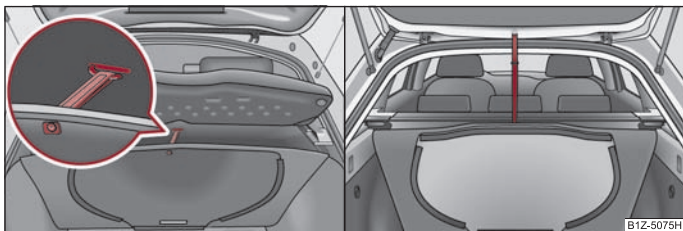

Fig. 70 Luggage compartment: Fixing of the floor covering Octavia/Estate car

There is a loop (Octavia) or there are hooks (Estate car) located on the floor covering of the luggage compartment. You can fix the raised floor cover with a hook to the luggage compartment cover (Octavia) ⇒ fig. 70 - left, as if one needs to reach the spare wheel or to the frame of the boot lid (Estate car) ⇒ fig. 70 - right. ■

Luggage net (Octavia)

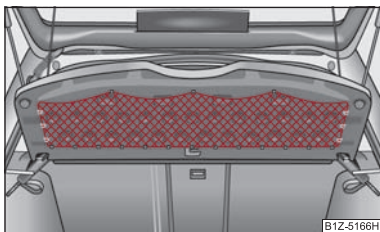

Fig. 71 Luggage compartment: Luggage net

The luggage net is designed for the transportation of lighter objects.

⚠ WARNING

- In the storage net you must only stow objects (up to a total weight of 1.5 kg). Heavy objects are not secured sufficiently - risk of injury!
- No objects with sharp edges should be stored in the luggage net, because they can damage the luggage net. ■

Luggage compartment cover (Octavia)

You can use the luggage compartment cover behind the head restraints for storing light and soft items.

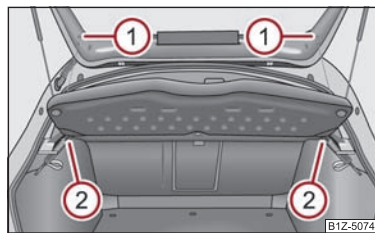

Fig. 72 Removing the luggage compartment cover

The luggage compartment cover can be removed as required if one must transport bulky goods.

- Unhook the support straps ① ⇒ fig. 72.
- Place the cover in the horizontal position.
- Pull the cover out of the holder ② horizontally to the rear.
- Install again by pushing the luggage compartment cover forwards into the holder ② and hanging the support straps ① on the boot lid.

You can stow the removed luggage compartment cover behind the rear seat backrest.

⚠ WARNING

No objects should be placed on the luggage compartment cover, the vehicle occupants could be endangered if there is sudden braking or the vehicle collides with something. ▶

⚠ Caution

Please ensure that the heating elements of the rear window heater are not damaged as a result of objects placed in this area.

i Note

Opening the tailgate also lifts up the luggage compartment cover. ■

Foldable luggage compartment cover (Estate car)

Fig. 73 Luggage compartment: foldable luggage compartment cover/removing foldable luggage compartment cover

Pulling out

- Pull the foldable luggage compartment cover in direction of arrow ① as far as the stop into the secured position ⇒ fig. 73.

Folding

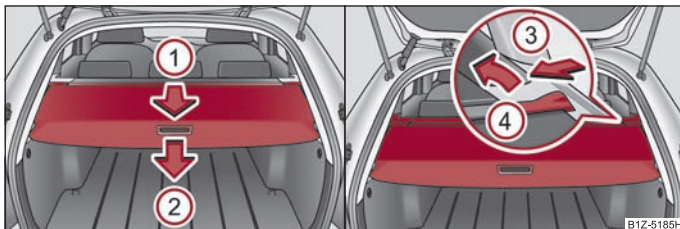
- Press the cover in the handle area in direction of arrow ②, the cover rolls up automatically.

Removing

- Have the completely rolled up luggage compartment cover removed to transport bulky goods by pressing on the side of the cross rod in direction of arrow ③ and taking it out by moving it in direction of arrow ④.

⚠ WARNING

No objects should be placed on the luggage compartment cover. ■

Division of the variable loading floor in the boot

Fig. 74 Luggage compartment: Dividing the luggage compartment with variable loading floor

The boot can be divided with the variable loading floor.

- Lift up the part with the holder and secure it by sliding it into the grooves ⇒ fig. 74. ■

Removing variable loading floor in the luggage compartment

Fig. 75 Luggage compartment: Remove variable loading floor/remove carrier rails

The variable loading floor makes handling of bulky items of luggage easier. You can remove the variable loading floor if necessary.

- Unlock the variable loading floor by turning the safety eyes A ⇒ fig. 75 to the left by around 90°.
- Fold together the loading floor and take it out by moving in direction of arrow.
- Unlock the carrier rails B by turning the arbor-mounted fixing eyes C to the right by approx. 90°.

⚠ WARNING

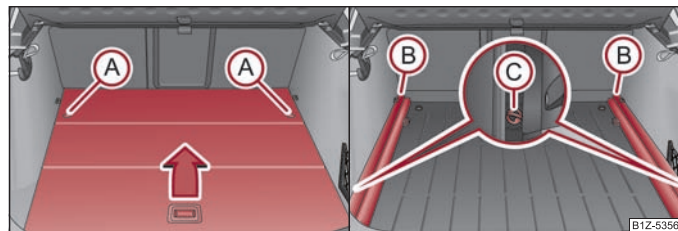
Pay attention when installing the variable loading floor that the carrier rails and the variable loading floor are correctly attached. If this is not the case, there is a risk of injury for the occupants.

⚠ Caution

The maximum load of the variable loading floor is 75 kg. ■

Net partition (Estate)**Use the luggage net partition behind the rear seats**

Fig. 76 Folding down the storage compartment cover/pulling out the luggage net partition

Pulling out

- Fold down the storage compartment cover behind the rear seats ⇒ fig. 76 - left.
- Pull the luggage net partition at the bracket (A) out of the housing (B) in direction of the holders (C).
- Insert the cross rod into one of the mounts (C) and push the cross rod forward.
- In the same way, fix the cross rod to the other side of the vehicle, mount (C).
- Fold the stowage compartment cover downwards.

Folding

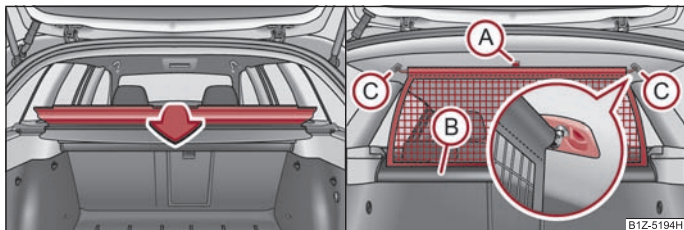
- Fold down the stowage compartment cover behind the rear seats ⇒ fig. 76.

- Pull the cross rod back slightly, first on the one side then on the other side and take the cross rod out of the mounts (C).
- Hold the cross rod in such a way that the luggage net partition can roll up slowly and without damage into the housing (B).
- Fold the stowage compartment cover downwards.

If you wish to use the entire luggage compartment, you can remove the foldable luggage compartment cover ⇒ page 75, fig. 73.

⚠ WARNING

- First check for yourself that the cross rod is inserted into the mounts (C) in the front position!
- Pay attention that the rear seat backrest is correctly interlocked. It is only then that the three-point seat belt for the middle seat can reliably fulfil its function. ■

Use the luggage net partition behind the front seats

Fig. 77 Pull out the luggage net partition

Pulling out

- Fold the rear seats forwards ⇒ page 68
- Pull the net partition at the bracket (A) ⇒ fig. 77 out of the housing (B)
- Insert the cross rod into the mount (C) first on the one side and push the cross rod forward.
- In the same way, fix the cross rod to the other side of the vehicle, mount (C). ▶

Folding

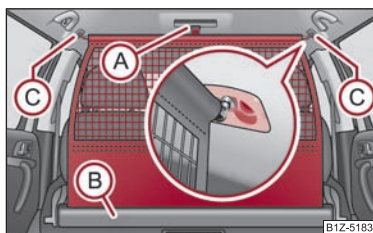
- Pull the cross rod back slightly, first on the one side then on the other side and take the cross rod out of the mounts (C).
- Hold the cross rod in such a way that the luggage net partition can roll up slowly and without damage into the housing (B).
- Fold the rear seats back into its original position.

⚠ WARNING

- The belt locks and the belts must be in their original position after folding back the seat cushions and the seat backrests - they must be ready to use.
- The seat backrests must be securely interlocked in position so that no objects in the luggage compartment can slide forwards if there is sudden braking - risk of injury!
- Pay attention that the rear seat backrest is correctly interlocked. It is only then that the three-point seat belt for the middle seat can reliably fulfil its function.
- First check for yourself that the cross road is inserted into the mounts (C) in the front position! ■

Removing and installing the luggage net partition housing

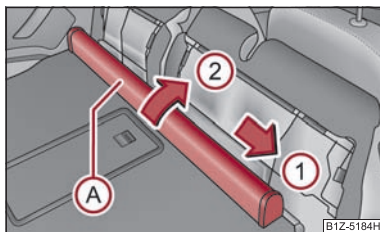

Fig. 78 Rear seats: Luggage net partition housing

Removing

- Fold the rear seats forwards ⇒ page 68
- Open the right rear door.
- Push the luggage net partition housing (A) ⇒ fig. 78 in the direction of arrow ① and take it out of the mount of the rear seats in the direction of arrow ②.

Installing

- Position the luggage net partition housing into the mounts in the rear seat backrests.
- Push the luggage net partition housing in the opposite direction of arrow ① as far as the stop.
- Fold the rear seats back into its original position.

⚠ WARNING

Pay attention that the rear seat backrest is correctly interlocked. It is only then that the three-point seat belt for the middle seat can reliably fulfil its function. ■

The roof rack

Description

⚠ Caution

- Only use roof racks approved by Škoda.
- If you use other roof rack systems or if the roof bars are not properly fitted, then any damage which may result to your car is not covered by the warranty agreements. It is therefore essential to pay attention to the fitting instructions supplied with the roof luggage rack system.
- On models fitted with a power sliding/tilting roof, ensure that the opened sliding/tilting roof does not strike any items of luggage transported on the roof.
- Ensure that the opened boot lid does not collide with the roof load.



For the sake of the environment

The increased aerodynamic drag results in a higher fuel consumption.



Note

If a roof rack has not been factory-fitted onto a vehicle, you can purchase one from Škoda original accessories. ■

Lashing points (Octavia)

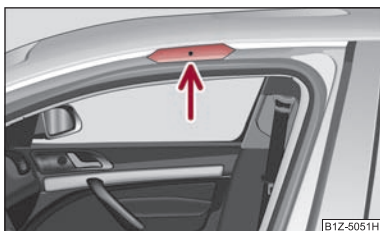

Fig. 79 Attachment points for base roof carrier

Perform the assembly and the disassembly according to the attached instructions.

Note

- If you have any questions, please contact a specialist garage.
- The figure is not valid for an estate car. ■

Roof load

Distribute weight evenly over the roof luggage rack system. The maximum permissible roof load (including roof rack system) of **75 kg** and the maximum permissible total weight of the vehicle should not be exceeded.

You cannot make full use of the permissible roof load if you use a roof luggage rack system with a lower load carrying capacity. The load transported on the roof luggage rack system must not exceed the weight limit which is stated in the fitting instructions.

WARNING

- **The items which you transport on the roof bar system must be reliably attached - risk of accident!**
- **You must on no account exceed the permissible roof load, the permissible axle loads and the permissible gross weight of your vehicle - risk of accident!**
- **Please note that the handling properties of your vehicle change when you transport heavy or bulky items on the roof bar system as a result of the displacement of the centre of gravity and the increased wind attack area - risk of acci-**

WARNING (continued)

dent! You must absolutely adapt your style of driving and the speed of the vehicle to the specific circumstances. ■

Cup holder

Cup holder in front centre console

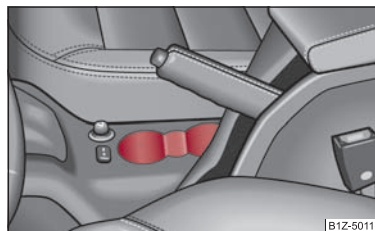

Fig. 80 Front centre console: Cup holder

You can place two cups or beverage cans into the recesses ⇒ fig. 80.

WARNING

- **Do not place any hot beverages into the cup holder. If the vehicle moves, they may spill - risk of scalding!**
- **Do not use any cups or beakers which are made of brittle material (e.g. glass, porcelain). You might be injured by them in the event of an accident.**

Caution

Do not open the beverages in the cup holder while driving. There is a risk of spilling e.g. when braking and therefore the electrical components or the seat upholstery can be damaged. ■

Cup holder in rear centre console

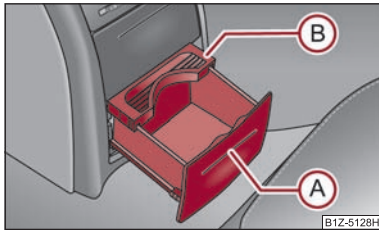

Fig. 81 Centre console at rear: Cup holder

- Press on the panel in the area (A) ⇒ fig. 81 - the cup holder comes out.
- Pull the cup holder out as far as the stop.
- Adjust the cup holder by moving the locking plate (B).

WARNING

- Do not place any hot beverages into the cup holder. If the vehicle moves, they may spill - risk of scalding!
- Do not use any cups or beakers which are made of brittle material (e.g. glass, porcelain). You might be injured by them in the event of an accident.

Caution

Do not open the beverages in the cup holder while driving. They may spill when braking and while doing so damage the vehicle. ■

Note holder

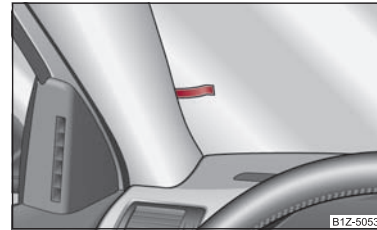

Fig. 82 Windscreen: Note holder

The parking ticket holder is designed e.g. for attaching a car park ticket in parking areas.

The attached note has to always be **removed** before starting off in order not to restrict the driver's vision. ■

Ashtray

Front ashtray

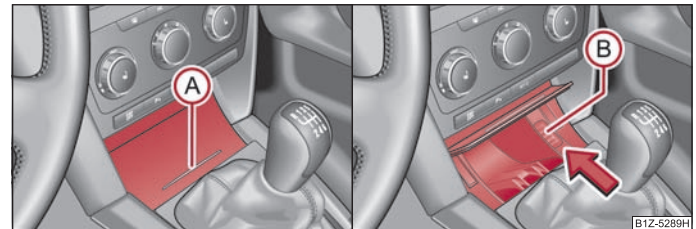

Fig. 83 Centre console: Front ashtray/remove front ashtray insert

Opening ashtray

- Press on the bottom part of the cover of the ashtray - refer to (A) ⇒ fig. 83. ►

Removing ashtray insert

- Press on the ashtray insert in the area (B) (the insert comes out) and you can take it out.

Insert ashtray insert

- Insert the ashtray insert into the mount and press it in.



WARNING

Never lay flammable objects in the ashtray basin - risk of fire! ■

Rear ashtray - low centre console

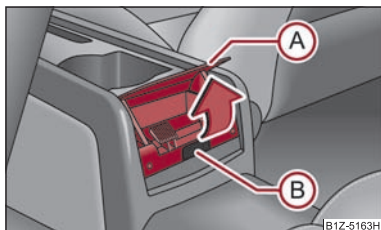

Fig. 84 Low centre console: Rear ashtray

Opening ashtray

- Grasp the ashtray cover at the lower edge (A) and fold it open in the direction of arrow ⇒ fig. 84.

Removing ashtray

- Grasp the ashtray at the handle (B) and pull it out in an upward direction.

Replacing ashtray

- Insert the ashtray into the console and press it in.



WARNING

Never lay flammable objects in the ashtray basin - risk of fire! ■

Rear ashtray - high centre console

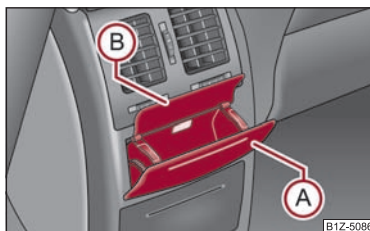

Fig. 85 High centre console: Rear ashtray

Opening ashtray

- Press on the top part of the cover of the ashtray in area (A) ⇒ fig. 85.

Removing ashtray insert

- Press the cover of the ashtray down slightly as far as the stop.
- Grasp the ashtray insert at the cover (B) and pull it out.

Insert ashtray insert

- Insert the ashtray insert into the mount and press it in.



WARNING

Never lay flammable objects in the ashtray basin - risk of fire! ■

Cigarette lighter, power sockets

Cigarette lighter

You can also use the socket on the cigarette lighter for other electrical appliances.



Fig. 86 Centre console: Cigarette lighter

Using the cigarette lighter

- Press in the button of the cigarette lighter ⇒ fig. 86.
- Wait until the button jumps forward.
- Remove the cigarette lighter immediately and use it.
- Insert the cigarette lighter again into the socket.

Using the socket

- Remove the cigarette lighter or the cover of the power socket.
- Connect the plug of the electrical appliance to the socket.

The 12 volt power socket can also be used to supply power to additional electrical accessories with a power uptake up to 120 watts.

WARNING

- Take care when using the cigarette lighter! Not paying proper attention or incorrect use the cigarette lighter in an uncontrolled manner may result in burns.
- The cigarette lighter and the power socket also operates when the ignition is switched off or the ignition key withdrawn. You should therefore never leave children unattended in the vehicle.

Caution

Always use matching plugs to avoid damaging the power socket.

Note

- Connecting electrical components when the engine is not running will drain the battery of the vehicle - risk of battery draining!
- Further information ⇒ page 204, "Accessories, changes and replacement of parts". ■

Power socket in the luggage compartment (Estate)

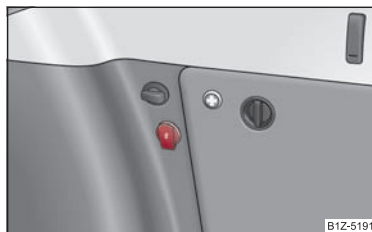

Fig. 87 Luggage compartment: Power socket

- Open the cover of the power socket ⇒ fig. 87.
- Connect the plug of the electrical appliance to the socket.

You can only use the power socket for the connection of approved electrical accessories with a power uptake up to 120 watts. The vehicle battery will be discharged in the process if the engine is stationary.

The same remarks apply here as for ⇒ page 81, "Cigarette lighter, power sockets". Further information ⇒ page 204, "Accessories, changes and replacement of parts". ■

Storage compartments

Overview

You will find the following storage facilities in your vehicle:

Storage compartment on the front passenger side	⇒ page 82
Storage compartment on the driver's side	⇒ page 83
Storage compartment on the dash panel	⇒ page 83
Stowage compartment in front centre console	⇒ page 84
Storage net on the front centre console	⇒ page 84
Stowage compartment for spectacles	⇒ page 84
Storage compartment in the front doors	⇒ page 85
Stowage compartment below front passenger seat	⇒ page 85
Front seat armrest with stowage compartment	⇒ page 85
Rear armrest with stowage compartment	⇒ page 86
Stowage compartment in rear centre console	⇒ page 86
Seat backrest with opening for skis	⇒ page 86
Removeable through-loading bag	⇒ page 87
Side compartment	⇒ page 88
Stowage compartment behind the rear seats (estate car)	⇒ page 88
Clothes hooks	⇒ page 88



WARNING

- Please do not place anything on top of the dash panel. Such objects might slide or fall down when driving (when accelerating or cornering) and may distract you from concentrating on the traffic situation - risk of accident!
- Ensure that when driving no objects from the centre console or from other storage possibilities may get into the footwell of the driver. You would then no longer be able to apply the brakes, operate the clutch or accelerator - risk of accident! ■

Storage compartment on the front passenger side



Fig. 88 Dash panel: Storage compartment on the front passenger side

Opening and closing the storage compartment on the front passenger side

- Press the handle of the lid ⇒ fig. 88 - the lid folds down.
- Raise the lid and press it until the catch is heard to engage.

There is a holder for a pen and note book on the inside of the lid.



WARNING

- The storage compartment must always be closed when driving for safety reasons.
- Do not place any beverages into the cup holder while driving. Spilled beverages can damage the electrical system and the upholstery. Hot beverages may result in burns. ■

Cooling of storage compartment on front passenger side

The storage compartment is for vehicles fitted with an air-conditioning system with a closable air supply.

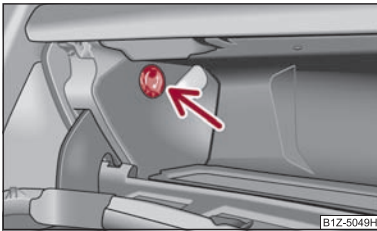

Fig. 89 Storage compartment: Using cooling system

- Open or close the air supply using the control dial ⇒ fig. 89.

Opening the air supply when the air conditioning system is switched on allows cooled air to flow into the storage compartment.

Opening the air inlet when the air conditioning system is on causes fresh or interior air to flow into the storage compartment.

We recommend that you close the air supply if it is operating in the heating mode or if you are not using the cooling system for the storage compartment. ■

Storage compartment on the driver's side

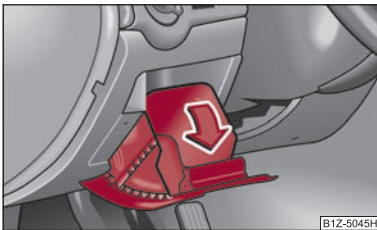

Fig. 90 Dash panel: Storage compartment on the driver's side

- The storage compartment is opened by lifting the handle and folding open in the direction of arrow ⇒ fig. 90.

WARNING

The storage compartment must always be closed when driving for safety reasons. ■

Storage compartment on the dash panel

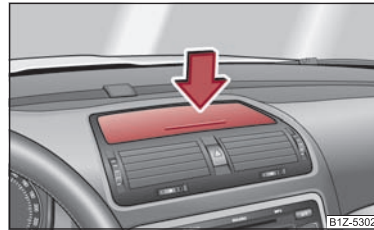

Fig. 91 Dash panel: Storage compartment

- Press in the middle of the storage compartment ⇒ fig. 91 - the lid folds open

Certain model versions are equipped without lid for the storage compartment.

WARNING

- The storage compartment is not a substitute for the ashtray and must also not be used for such purposes - risk of fire!
- The storage compartment must always be closed when driving for safety reasons.
- Do not put any highly inflammable objects or objects which are sensitive to heat (e.g. lighters, sprays, spectacles, carbonated drinks) in the storage compartment. ■

Stowage compartment in front centre console

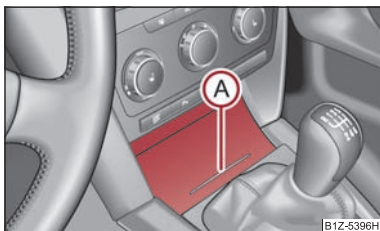

Fig. 92 Front centre console: Storage compartment

- Press on the bottom part of the storage compartment in the area (A) ⇒ fig. 92 - the lid opens.

⚠ WARNING

The storage compartment is not a substitute for the ashtray and must also not be used for such purposes - risk of fire! ■

Storage net on the front centre console

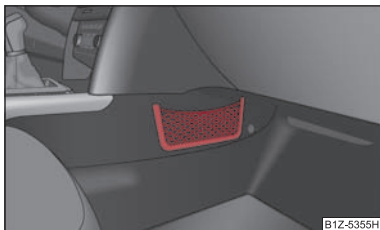

Fig. 93 Front centre console: Storage net

The storage net in the front center console ⇒ fig. 93 is designed for the transport of smaller objects.

⚠ WARNING

- In the storage net you must only stow objects (up to a total weight of 0.5 kg). Heavy objects are not secured sufficiently - risk of injury!
- No objects with sharp edges should be stored in the luggage net, because they can damage the luggage net. ■

Stowage compartment for spectacles

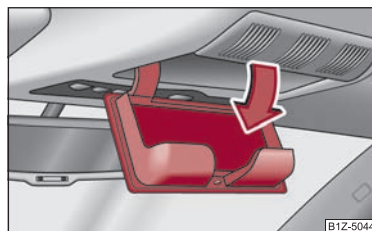

Fig. 94 Detail of the headliner: Stowage compartment for spectacles

- Press on the lid of the stowage compartment, the stowage compartment opens downwards ⇒ fig. 94.

⚠ Caution

- The compartment must only be opened when removing or inserting the spectacles and otherwise must be kept closed.
- Do not put any heat-sensitive objects in the stowage compartment - they may be damaged. ■

Storage compartment in the front doors

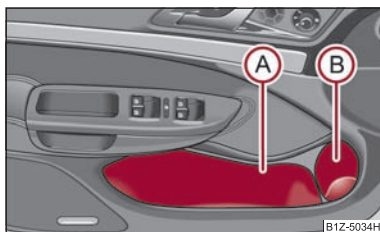

Fig. 95 Storage compartment in the front doors

A bottle holder is located in the area (B) of the storage compartment for the front doors.

⚠ WARNING

Use the area (A) ⇒ fig. 95 of the storage compartment only for storing objects which do not project so that the effectiveness of the side airbag is not impaired. ■

Stowage compartment below front passenger seat

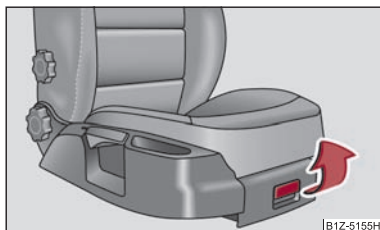

Fig. 96 Front passenger seat: Storage compartment

- Tilt the lock to open the flap and pull out the flap ⇒ fig. 96.
- Tilt the lock to close the flap and press flap close.

⚠ Caution

The storage compartment is foreseen for storing small objects of up to 1.5 kg. in weight. ■

Front seat armrest with storage compartment

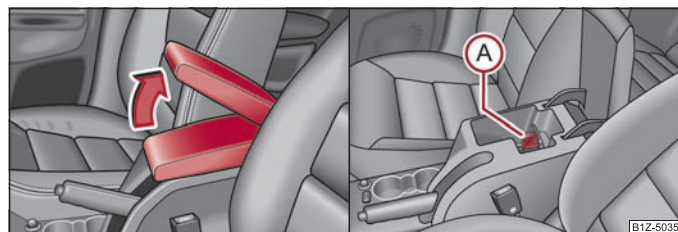

Fig. 97 Armrest: Storage compartment/cooling of storage compartment

The armrest is adjustable for height and length.

Opening stowage compartment

- Open the lid of the armrest in the direction of arrow ⇒ fig. 97 - left.

Closing stowage compartment

- Open the lid up to the stop, then you can fold it downwards.

Setting height

- First of all fold the lid to the bottom and lift it in the direction of arrow into one of the 4 fixed positions.

Adjusting in forward/back direction

- Push the lid into the desired position.

Opening air inlet

- Pull the lock (A) in upward direction. ▶

Closing air inlet

- Push the lock (A) as far as the stop downwards.

On vehicles fitted with air conditioning, the storage compartment is equipped with a lockable inlet for thermally treated (warmed-up) air.

At open air supply, air flows into the storage with a temperature which is as high as the one out of the air outlet nozzles, depending on temperature setting.

The air inlet in the storage compartment is connected to position 2 through adjustment of the control dial for air distribution. This position causes the maximum amount of air to flow into the storage compartment (depending on the rotary regulator position for the fan).

You can use the storage compartment, for example, to temper drinks cans, etc.

If you do not use the air inlet in the storage compartment, the end cover should always be kept closed.

Note

Push the lid of the armrest up to stop to the rear before operating the handbrake. ■

Rear seat armrest with storage compartment

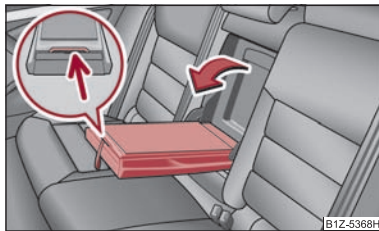

Fig. 98 Armrest of rear seats:

The armrest includes a stowage compartment. You open the compartment by pressing the button on the front side and raising the cover ⇒ fig. 98. ■

Stowage compartment in rear centre console

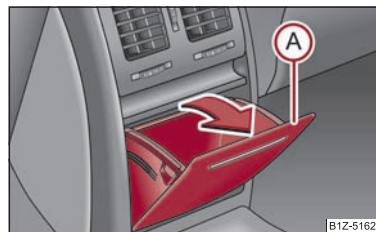

Fig. 99 Centre console at rear: Storage compartment

The storage compartment is equipped with a removeable insert.

- Open the storage compartment by pulling on the upper edge of the storage compartment (A) in the direction of arrow ⇒ fig. 99.

WARNING

The storage compartment is not a substitute for the ashtray and must also not be used for such purposes - risk of fire! ■

Seat backrest with opening for skis

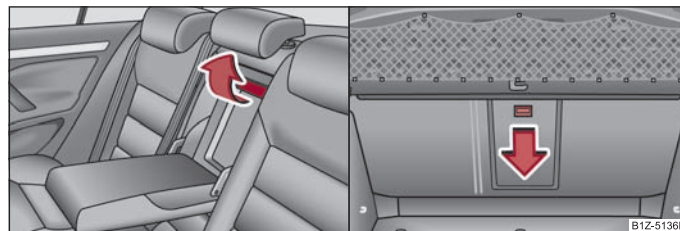

Fig. 100 Rear seats: Handle of lid/luggage compartment: Unlock button

After folding open the armrest and the lid, an opening in the seat backrest becomes visible through which you can push the removeable through-loading bag with skis. ►

You can fold open the armrest and the lid from the passenger or luggage compartment.

Opening from passenger compartment

- Fold down the armrest of the rear seat at the loop ⇒ page 70.
- Pull the handle up to the stop in upward direction and fold open the lid downwards ⇒ page 86, fig. 100 - left.

Opening from luggage compartment

- Push the unlock button downwards ⇒ page 86, fig. 100 - right and fold the lid (with armrest) to the front.

Closing

- Fold the lid and the armrest up to the stop in upward direction - the lid must click into place audibly.

Ensure that the armrest is always locked into place after closing. You can recognize this on the fact that the red field above the unlocking button (A) of the luggage compartment is not visible.

WARNING

The opening for the skis is solely used for transporting skis which are placed in a properly secured removable through-loading bag ⇒ page 87. ■

Through-loading bag

The removable through-loading bag is solely used for transporting skis.

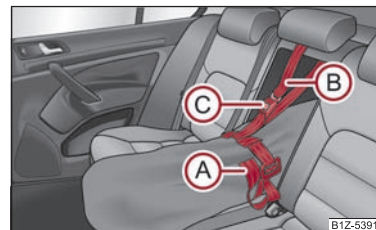



Fig. 101 Securing the removable through-loading bag

Loading

- Open the boot lid/luggage compartment door.
- Fold the rear armrest and the cover in the seat backrest downwards ⇒ page 86, "Seat backrest with opening for skis".
- Place the empty removable through-loading bag in such a way that the end of the bag with the zip lies in the boot.
- Push the skis into the removable through-loading bag from the luggage compartment ⇒ .

Securing

- Tighten the strap (A) on the free end around the skis in front of the bindings ⇒ fig. 101.
- Fold the seat backrest a little forward.
- Guide the securing strap (B) through the opening in the seat backrest around the upper part of the seat backrest.
- Then push the seat backrest back into the upright position until the locking button clicks into place - check by pulling on the seat backrest.
- Insert the securing strap (B) into the lock (C) until it is heard to lock in place.

On vehicles fitted with a luggage net partition, guide the securing strap (B) around the housing when the net partition is rolled up. After fixing the luggage net partition in place, it is not longer possible to unroll the luggage net partition. ►

WARNING

- After placing skis into the through-loading bag, you must secure the bag with the securing strap **(B)**.
- The strap **(A)** must hold the skis tight.
- Make sure that the strap **(A)** holds the skis in front of the binding (see also imprint on the removeable through-loading bag).

Note

- The through-loading bag is foreseen for four pairs of skis. The total weight of the skis which are transported must not exceed 17 kg.
- You must put the skis and the sticks in the removeable through-loading bag with the tips facing the rear.
- If there are several pairs of skis in the removeable through-loading bag, ensure that the bindings are positioned at the same height.
- Carefully fold the empty (dry) through-loading bag together, place it in the luggage compartment and secure it to prevent it slipping. The removeable through-loading bag must never be folded together or stowed when moist. ■

Side compartment

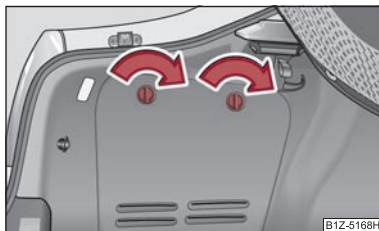

Fig. 102 Luggage compartment: Side compartment

- You can open the compartment by turning the locks in the direction of arrow.

The CD changer is housed in this compartment. ■

Stowage compartment behind the rear seats (estate car)

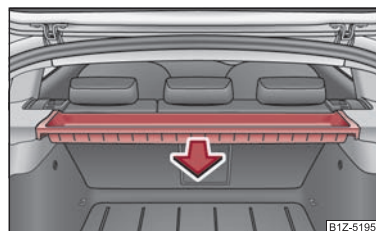

Fig. 103 Removing the stowage compartment

Removing

- First remove the foldable luggage compartment cover ⇒ page 75.
- Grasp the housing with both hands and remove it by pulling in direction of arrow ⇒ fig. 103.

Installing

- Push the housing up to the stop into the catch.
- Re-insert the foldable luggage compartment cover.

WARNING

Only place small and light objects up to a total weight of 3 kg into the stowage compartment. In the event of a vehicle collision heavy objects could be thrown out of the compartment - risk of injuries! For this reason, the front part of the luggage compartment cover must always cover over the stowage compartment. ■

Clothes hooks

The clothes hooks are located on the middle pillar and on the handle of the headliner above each of the rear doors. ►

**WARNING**

- Ensure that any clothes hanging from the hooks do not impair your vision to the rear.
- Use the hooks for hanging only light items of clothing and ensure that there are no heavy or sharp-edged objects in the pockets.
- The maximum permissible load of the hooks is 2 kg.
- Do not use clothes hangers for hanging up items of clothing otherwise this will interfere with the protection offered by the head airbag. ■

Heating and air conditioning system

Introduction

Description and information

The heating effect is dependent upon the coolant temperature, thus full heat output only occurs when the engine has reached its operating temperature.

If the cooling system is switched on, the temperature and air humidity drops in the vehicle. The wellbeing of the occupants of the car is enhanced as a result of this particularly at high outside temperatures and a high air humidity. The system prevents the windows misting up during the cold season of the year.

It is possible to briefly activate recirculated air mode in order to enhance the cooling effect - air-conditioning system ⇒ page 97, Climatronic ⇒ page 99.

The air inlet in front of the windscreen must be free of ice, snow or leaves in order to ensure that the heating and cooling systems operate properly.

After switching on the cooling **Condensation** from the evaporator of the air conditioning may drip down and form a puddle below the vehicle. This is quite normal and not an indication of a leak!



WARNING

- For your own safety and that of other road users, ensure that all the windows are free of ice, snow and misting. Please familiarize yourself about how to correctly operate the heating and ventilation systems, how to demist and defrost the windows, as well as with the cooling mode.
- You should not leave recirculated air mode on over a longer period of time, as "stale" air may result in fatigue in the driver and occupants, divert your attention and also cause the windows to mist up. The risk of having an accident increases. Switch recirculated air mode off as soon as the windows begin misting up.



Note

- The used air streams out through the air removal openings in the luggage compartment.
- We recommend that you do not smoke in the vehicle when the recirculating air mode is operating since the smoke which is drawn at the evaporator from the interior of the vehicle forms deposits in the evaporator of the air conditioning system.

This produces a permanent odour when the air conditioning system is operating which can only be eliminated through considerable effort and expense (replacement of compressor).

- Please refer to the information regarding the recirculated air mode for heating ⇒ page 94 and/or for air-conditioning system ⇒ page 97 or Climatronic ⇒ page 99.
- To ensure the heating system, air conditioning system or Climatronic work perfectly, the air outlet vents must not be covered by any objects. ■

Using the air conditioning system economically

The compressor on the air conditioning system uses power from the engine when in cooling mode which will effect the fuel consumption.

It recommended to open the windows or the doors of a vehicle for which the interior has been strongly heated through the effect of direct sunlight in order to allow the heated air to escape.

The cooling system should not be switched on while travelling when the window is open.

The desired interior temperature can also be achieved without switching in the cooling system just by switching to fresh air mode.



For the sake of the environment

When you economize on fuel, you also reduce pollutant emissions. ■

Operational problems

If the cooling system does not operate at outside temperatures higher than +5 °C, there is a problem in the system. The reasons for this may be:

- The fuse on the air conditioning system has blown. Check the fuse, replace it if necessary ⇒ page 217.
- The cooling system has switched off automatically for a short time because the coolant temperature of the engine is too hot ⇒ page 16.

If you are not able to rectify the operational problem yourself, or if the cooling capacity decreases, switch the cooling system off. Contact a specialist garage. ■

Air outlet vents

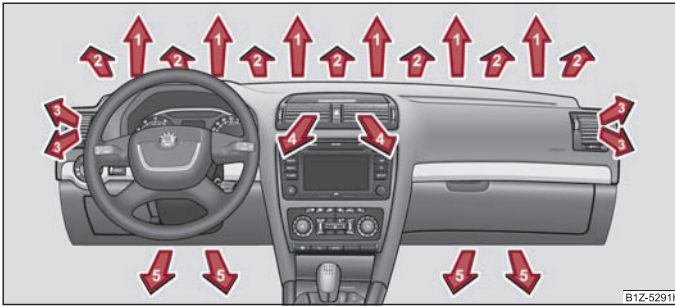

Fig. 104 Air vents at the front

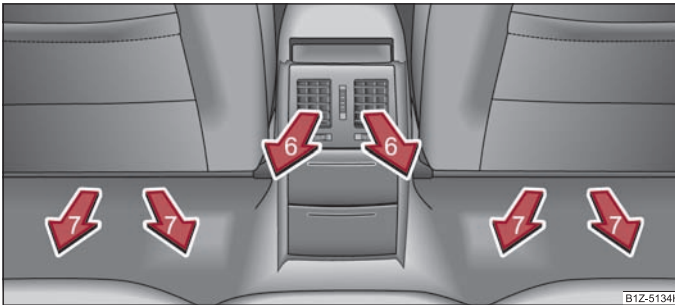

Fig. 105 Air vents at the rear

Open air outlet vents

- Turn the vertical thumbwheel (not when in the end position).

Close air outlet vents

- Turn the vertical wheel into the end position.

Redirecting air flow

- Swivel upward or downward the grille of the vents in order to change the direction of the air flow using the vertically arranged thumbwheel.
- Turn the horizontal thumbwheel on the vent to the right or left in order to change the air flow to the appropriate side.

The air outlet vents 3, 4 → fig. 104 and 6 → fig. 105 can be closed and opened individually.

The air outlet vents 6 are only fitted on vehicles with higher centre console.

Warmed, unwarmed or cooled air will flow out of the air outlet vents according to the setting of the regulator of the heating or the air conditioning system and the atmospheric conditions.

Note

The air outlet vents 2 ensure in the ventilation and cooling mode for a comfortable (no-draught) ventilation of the interior of the vehicle, also if the air outlet vents 4 are closed. ■

Heating

Using the system

The heating system delivers air into the interior of the vehicle and warms it as required.

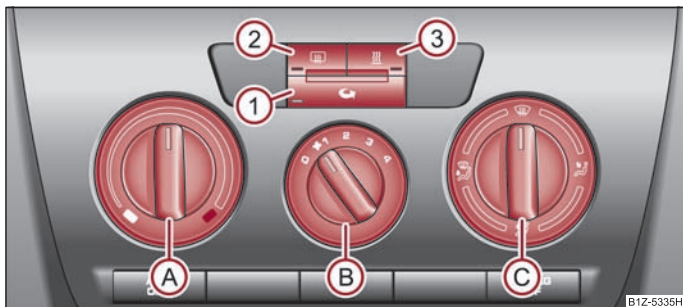

Fig. 106 Heating: Control elements

Setting temperature

- Turn the control dial (A) ⇒ fig. 106 to the right in order to increase the temperature.
- Turn the control dial (A) to the left in order to decrease the temperature.

Controlling blower

- Turn the blower switch (B) into one of the positions, 1 to 4, in order to switch the blower on.
- Turn the blower switch (B) into position 0 in order to switch the blower off.
- If you wish to shut off the fresh air supply, use the button (1) - recirculated air mode ⇒ page 94.

Control for air distribution

- You can adjust the direction of the air flow using the air distribution control (C) ⇒ page 91.

Rear window heater

- Press button (2). Further information ⇒ page 56, "Rear window heater".

Auxiliary heating (auxiliary heating)

- Press the button (3) in order to directly switch on/off the auxiliary heating (auxiliary heating and ventilation). Further information ⇒ page 100, "Auxiliary heating (auxiliary heating and ventilation)".

All controls apart from the control dial (B) can be set to any desired intermediate position.





The blower should always be on to prevent the windows from misting up.

Note

If the air distribution is positioned towards the windows, the total amount of air is used to defrost the windows and thus no air will be fed to the footwell. This can lead to restriction of the heating comfort. ■

Set heating

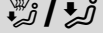
Recommended basic settings of heating controls for:

Set-up	Setting of the control dial			Button ①	Air outlet vents 3
	Ⓐ	Ⓑ	Ⓒ		
Defrosting the windscreen and side windows	To the right up to the stop	3		Do not switch on	Open and align with the side window
Free windscreen and side windows from mist	Desired temperature	2 or 3		Do not switch on	Open and align with the side window
The fastest heating	To the right up to the stop	3		briefly switched on	Opening
Comfortable heating	Desired temperature	2 or 3		Do not switch on	Opening
Fresh air mode - ventilation	To the left up to the stop	Desired position		Do not switch on	Opening

Note

- Controls Ⓐ, Ⓑ, Ⓒ and the button ① ⇒ page 92, fig. 106.
- Air outlet vents 3 ⇒ page 91, fig. 104.
- We recommend that you leave the air outlet vents 4 ⇒ page 91, fig. 104 in the opened position. ■

Recirculated air mode

In recirculated air mode air is sucked out of the interior of the vehicle and then fed back into the interior.



Recirculated air mode prevents polluted air outside the vehicle from getting into the vehicle, for example when driving through a tunnel or when standing in a traffic jam.

Switching recirculated air mode on

- Press the button  - the warning light lights up in the button \Rightarrow page 92, fig. 106.

Switching recirculated air mode off

- Press again the button  - the warning light in the button goes out.

The recirculated air mode is switched off automatically if the air distribution control  is in position  \Rightarrow page 92, fig. 106. You can also switch recirculated air mode on again from this setting by repeatedly pressing pushbutton .

WARNING

You should not leave recirculated air mode on over a longer period of time, as "stale" air may result in fatigue in the driver and occupants, divert your attention and also cause the windows to mist up. The risk of having an accident increases. Switch recirculated air mode off as soon as the windows begin misting up. ■

Air conditioning system (manual air conditioning system)

Description

The air conditioning system is a combined cooling and heating system. It makes it possible to optimally control the air temperature at any season of the year.

Description of the air conditioning system

It is important for your safety and for your driving comfort that the air conditioning system is operating properly.

The cooling only operates if button  \Rightarrow fig. 107  is pressed, and the following conditions are met:

- engine running,
- outside temperature above approx. +2 °C and
- blower switch switched on (positions 1 to 4).

Air at a temperature of about 5 °C may flow out of the vents under certain circumstances when the cooling system is operating. Lengthy and uneven distribution of the air flow out of the vents and large differences in temperature, for example when getting out of the vehicle, can result in chills in sensitive persons.

Note

- We recommend that you have the air conditioning system cleaned by a specialist garage once every year.
- In countries with high humidity, we recommend you do not use this setting. ■

Using the system

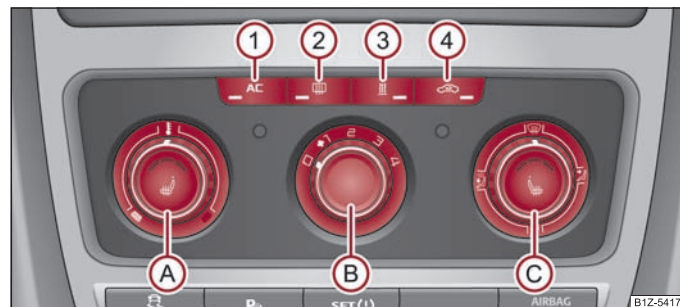







Fig. 107 The air conditioning system: Control elements

Setting temperature

- Turn the control dial  \Rightarrow fig. 107 to the right in order to increase the temperature.
- Turn the control dial  to the left in order to increase the temperature. ▶



Controlling blower

- Turn the blower switch  into one of the positions, 1 to 4, in order to switch the blower on.
- Turn the blower switch  into position 0 in order to switch the blower off.
- If you wish to shut off the fresh air supply, use the button   - recirculated air mode ⇒ page 97.



Control for air distribution

- You can adjust the direction of the air flow using the air distribution control  ⇒ page 91.



switching cooling on and off

- Press the button   ⇒ fig. 107. The warning light lights up in the button.
- When you again press the switch , the cooling system is switched off. The warning light in the button goes out.

Rear window heater

- Press button  . Further information ⇒ page 56, "Rear window heater".

Auxiliary heating (auxiliary heating)

- Press the button   in order to directly switch on/off the auxiliary heating (auxiliary heating and ventilation. Further information ⇒ page 100, "Auxiliary heating (auxiliary heating and ventilation)".









Note

- The whole heat output will be needed to unfrost the windscreen and side windows. No warm air will be fed to the footwell. This can lead to restriction of the heating comfort.
- The warning light  lights after activation, even if not all of the conditions for the function of the cooling system have been met. As a result, the readiness for cooling is signalled when all conditions are satisfied ⇒ page 94, "Description of the air conditioning system". ■

Setting air conditioning system

Recommended basic settings of the control elements of the air conditioning system for the respective operating modes:

Set-up	Setting of the control dial			Button		Air outlet vents 3
	(A)	(B)	(C)	(1)	(4)	
Defrost windscreen and side windows - remove mist ^{a)}	Desired temperature	3 or 4		Activated automatically ^{b)}	Do not switch on	Open and align with the side window
The fastest heating	To the right up to the stop	3		Switched off	briefly switched on	Opening
Comfortable heating	Desired temperature	2 or 3		Switched off	Do not switch on	Opening
The fastest cooling	To the left up to the stop	briefly 4, then 2 or 3		Activated	briefly switched on	Opening
optimal cooling	Desired temperature	1, 2 or 3		Activated	Do not switch on	Open and align to the roof
Fresh air mode - ventilation	To the left up to the stop	Desired position		Switched off	Do not switch on	Opening

^{a)} In countries with high humidity, we recommend you do not use this setting. This can result in heavy cooling of the window glass and the following fogging from outside.

^{b)} The warning light in the (1) button lights after activation, even if not all of the conditions for the function of the cooling system have been met. As a result, the readiness for cooling is signalled when all conditions are satisfied ⇒ page 94, "Description of the air conditioning system".



Note

- Controls (A), (B), (C) and the (1) button and (4) ⇒ page 94, fig. 107.
- Air outlet vents 3 ⇒ page 91, fig. 104.
- We recommend that you leave the air outlet vents 4 ⇒ page 91, fig. 104 in the opened position. ■

Recirculated air mode

In recirculated air mode air is sucked out of the interior of the vehicle and then fed back into the interior.



Recirculated air mode prevents polluted air outside the vehicle from getting into the vehicle, for example when driving through a tunnel or when standing in a traffic jam.

Switching recirculated air mode on

- Press the button  (4) ⇒ page 94, fig. 107 the warning light lights up in the button.

Switching recirculated air mode off

- Press again the button  - the warning light in the button goes out.

The recirculated air mode is switched off automatically if the air distribution control  is in position  ⇒ page 94, fig. 107. You can also switch recirculated air mode on again from this setting by repeatedly pressing pushbutton .

WARNING

You should not leave recirculated air mode on over a longer period of time, as "stale" air may result in fatigue in the driver and occupants, divert your attention and also cause the windows to mist up. The risk of having an accident increases. Switch recirculated air mode off as soon as the windows begin misting up. ■

Climatronic (automatic air conditioning)

Description

The Climatronic system is an automatic heating, fresh air and cooling system which provides optimal comfort for the occupants of the car.

The Climatronic maintains fully automatically a convenience temperature. This is achieved by automatically varying the temperature of the outflowing air, the blower stages and the air distribution. The system also takes into account sunlight which eliminates the need to alter the settings manually. The **automatic mode** ⇒ page 98 ensures maximum wellbeing of the occupants at all times of the year.

Description of Climatronic system

The cooling operates only if the following conditions are met:

- engine running,
- outside temperature above approx. +2 °C,
-  switched on.

The AC compressor is switched off at a high coolant temperature in order to provide cooling at a high load of the engine.

Recommended setting for all periods of the year:

- Set the desired temperature, we recommend 22 °C.
- Press the button  ⇒ page 98, fig. 108.
- Move the air outlet vents **3** and **4** so that the air flow is directed slightly upwards.

Note

- We recommend that you have Climatronic cleaned by a specialist garage once every year.
- On vehicles equipped with a factory-fitted radio or radio navigation system, the information of the Climatronic is also shown on the display. This function can be switched off, see operating instructions of the radio or the radio navigation system. ■

Overview of the control elements

The controls enable a separate setting of the temperature for the left and right side.

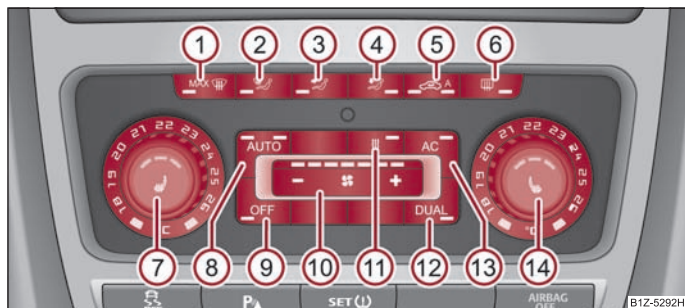

Fig. 108 Climatronic: Control elements

The buttons

- ① Defrost windscreen intensively (MAX)
- ② Air flow to the windows
- ③ Air flow to head
- ④ Air flow in the footwell
- ⑤ Recirculated air mode with air quality sensor
- ⑥ Rear window heater

Buttons/control dial

- ⑦ Setting of the temperature for the left side, operation of the seat heating of the left front seat
- ⑧ Automatic mode (AUTO)
- ⑨ Switching off Climatronic (OFF)
- ⑩ Setting the blower speed
- ⑪ Button for direct switching on/off of auxiliary heating (auxiliary heating) ⇒ page 100
- ⑫ Switching on/off of the temperature setting in dual mode (DUAL)
- ⑬ Switching cooling on and off (AC)
- ⑭ Setting of the temperature for the right side, operation of the seat heating of the right front seat

Note

Below the top row of buttons is located the interior temperature sensor. Do not glue or cover over the sensor, otherwise it could have an unfavourable effect on the Climatronic. ■

Automatic mode

The automatic mode is used in order to maintain a constant temperature and to demist the windows in the interior of the car.

Switching automatic mode on

- Set a temperature between +18 °C and +26 °C.
- Move the air outlet vents 3 and 4 ⇒ page 91, fig. 104, so that the air flow is directed slightly upwards.
- Press the button (AUTO). In the right or left top corner a warning light lights up, depending on which unit was last selected.

If the warning light in the top right corner of the button (AUTO) lights up, the Climatronic operates in "HIGH" mode. The "HIGH" mode is the standard setting of the Climatronic.

When pressing again the button (AUTO), the Climatronic changes into the "LOW" mode and the warning light in the top left corner lights up. The Climatronic uses only in this mode the lower blower speed. However taking into account the noise level, this is more comfortable, yet be aware that the effectiveness of the air conditioning system is reduced particularly if the vehicle is fully occupied.

By pressing again the button (AUTO), you change into the "HIGH" mode.

The automatic mode is switched off by pressing the button for the air distribution or increasing or decreasing the blower speed. The temperature is nevertheless regulated. ■

switching cooling on and off

switching cooling on and off

- Press the button (AC) ⇒ fig. 108. The warning light lights up in the button.
- When you again press the switch (AC), the cooling system is switched off. The warning light in the button goes out. Only the function of the ventilation remains active when no lower temperature than the outside temperature can be reached. ■

Setting temperature

You can separate the interior temperature for the left and right side separately.

- You can set the temperature for both sides after switching on the ignition with the control dial (7) → page 98, fig. 108.
- If you wish to set the temperature for the right side, turn the control dial (14). The warning light in the button (DUAL) lights up, this indicates that differing temperatures for the left and right side can be set.

If the warning light in the button (DUAL) lights up, the temperature for both sides cannot be set with the control dial (7). You can reinstate this function by pressing the button (DUAL). The warning light in the button which indicates the possibility to set differing temperatures for the left and right side, goes out.

You can set the interior temperature between +18 °C and +26 °C. The interior temperature is regulated automatically within this range. If you chose a temperature lower than +18 °C, a blue symbol lights up at the start of the numerical scale. If you chose a temperature higher than +26 °C, a red symbol lights up at the end of the numerical scale. In both limit positions the Climatronic operates at maximum cooling or heating capacity, respectively. The temperature is not controlled in this case.

Lengthy and uneven distribution of the air flow out of the vents (in particular at the leg area) and large differences in temperature, for example when getting out of the vehicle, can result in chills in sensitive persons. ■

Recirculated air mode

In recirculated air mode air is sucked out of the interior of the vehicle and then fed back into the interior. When the automatic air distribution control is switched on, an air quality sensor measures the concentration of pollutants in the drawn-in air.

Recirculated air mode prevents polluted air outside the vehicle from getting into the vehicle, for example when driving through a tunnel or when standing in a traffic jam. If a considerable increase in concentration of pollutants is recognized by the air quality sensor, when the automatic air distribution control is switched on, the air distribution control will temporarily be switched off. If the concentration of pollutants decreases to the normal level, the air distribution control is automatically switched off so that fresh air can be guided into the vehicle interior.

Switching recirculated air mode on

- Press the button repeatedly (AC) until the warning light on the left side of the button lights up.

Switch on automatic air distribution control

- Press the button repeatedly (AC) until the warning light on the right side of the button lights up.

Switch off automatic air distribution control temporarily

- If the air quality sensor does not switch on the air distribution control automatically when there is a nauseating smell, you can switch it on yourself by pressing the button (AC). The warning light lights up in the button on the left side.

Switching recirculated air mode off

- Press the button (AUTO) or press the button (AC) repetitively, until the warning lights in the button go out.

WARNING

You should not leave recirculated air mode on over a longer period of time, as "stale" air may result in fatigue in the driver and occupants, divert your attention and also cause the windows to mist up. The risk of having an accident increases. Switch recirculated air mode off as soon as the windows begin misting up.

Note

- If the windscreen mists up, press the button (MAX) (1) → page 98, fig. 108. After the windscreen has been demisted, press the button (AUTO).
- The automatic air distribution control operates only if the outside temperature is higher than approx. 2 °C. ■

Controlling blower

There are a total of seven blower stages available.

The Climatronic system controls the blower stages automatically in line with the interior temperature. You can also, however, adapt the blower stages manually to suit your particular needs.

- Press again the button (F) on the left side (reduce blower speed) or on the right side (increase blower speed). ▶

If you switch off the blower, the Climatronic is switched off.

The set blower speed is displayed above the button  when the respective number of warning lights come on.



WARNING

- "Stale air" may result in fatigue in the driver and occupants, reduce attention levels and also cause the windows to mist up. The risk of having an accident increases.
- Do not switch the Climatronic system off for longer than necessary.
- Switch the Climatronic system on as soon as the windows mist up. ■

Defrosting windscreen

Defrosting windscreen - switching on

- Press the button  ⇒ page 98, fig. 108.

Defrosting windscreen - switching off

- Once again press the button  or the button .

The temperature control is controlled automatically. More air flows out of the air outlet vents 1. ■

Auxiliary heating (auxiliary heating and ventilation)

Description and important information

The auxiliary heating (auxiliary heating and ventilation) heats or supplies the interior of the vehicle with fresh air independent of the engine.

Auxiliary heating (auxiliary heating)

The auxiliary heating (auxiliary heating) functions in connection with the heating system. Air-conditioning system or Climatronic.

It can be used when stationary, when engine is switched off for preheating of the vehicle as well as while driving (e.g. during the heating phase of the engine).

The engine is also preheated when the vehicle is stationary and the engine is switched off, if the auxiliary heating is switched on.

The auxiliary heating (auxiliary heating) warms up the coolant during the combustion of fuel from the vehicle tank. The coolant warms up the air, which (if the blower speed is not set to zero) flows into the occupant compartment.

Auxiliary ventilation

The auxiliary ventilation enables fresh air to flow into the vehicle interior by switching off the engine, whereby the interior temperature is effectively decreased (e.g. with the vehicle parked in the sun).



WARNING



- The auxiliary heating must never be operated in closed rooms - risk of poisoning!
- The auxiliary heating must not be running during refueling - risk of fire.
- The exhaust pipe of the auxiliary heating is located on the underside of the vehicle. Therefore do not place the vehicle, if you wish to operate the auxiliary heating, in such a way that the exhaust gases of the auxiliary heating can come easily into contact with inflammable materials (e.g. dry grass) or easily inflammable substances (e.g. fuel run out).



Note

If the auxiliary heating runs, the fuel consumption comes from the vehicle tank. The auxiliary heating automatically controls the filling level in the fuel tank. If only a low quantity of fuel is present in the fuel tank, the function of the auxiliary heating is blocked.

- The exhaust pipe of the auxiliary heating, which is located on the underside of the vehicle, must not be clogged and the exhaust flow must not be blocked.
- If the auxiliary heating and ventilation is running, the vehicle battery discharges. If the auxiliary heating and ventilation has been operated several times over a longer period, the vehicle must be driven a few kilometers in order to recharge the vehicle battery.
- The auxiliary heating only switches the blower on, if it has achieved a coolant temperature of approx. 50 °C.
- At low outside temperatures, this can result in a formation of water vapour in the area of the engine compartment. This is quite normal and is not an operating problem.
- After switching off the auxiliary heating, the coolant pump runs for a short period. ▶

- The auxiliary heating and ventilation does not switch on or comes on, if the vehicle battery indicates a low loading state.
- The auxiliary heating (auxiliary heating) does not switch on, if the following was shown in the information display or before switching off the ignition: **Please refuel!**
- The air inlet in front of the windscreen must be free of ice, snow or leaves in order to ensure that the auxiliary heating operates properly.
- So that warm air can flow into the vehicle interior after switching on the auxiliary heating, you must maintain the comfort temperature normally selected by you and leave the air outlet vents in an open position. It is recommended to put the air flow in the position  or . ■

Direct switching on/off



Fig. 109 Button for direct switching on/off of the auxiliary heating (auxiliary heating and ventilation) on the operating part of the air conditioning system

The auxiliary heating (auxiliary heating and ventilation) can be switched on or off **directly** with the  button on the air conditioning system, Climatronic- or heating ⇒ [fig. 109](#).

If the auxiliary heating and ventilation is not switched off earlier, it switches off automatically after the expiration of the set operating period, in the menu **Running time**. ■

Using the system

So that the auxiliary heating (auxiliary heating and ventilation) functions according to your expectations, it is necessary to carry out the basic setting before its programming.

Basic setting

- On the information display, select in the **Main menu** the menu point **Aux. heating**.
- In the menu **Aux. heating** select the menu point **Day of the wk.** and set today's date.
- By selecting the menu point **Back**, you will reach one level higher in the menu **Aux. Heating**.
- In the menu **Aux. Heating** choose the menu point **Running time** and set the required lifetime in steps of 5 minutes. The running time can be 10 to 60 minutes.
- By selecting the menu point **Back**, you will reach in the menu **Aux. heating**.
- In the menu **Aux. heating** select the menu point **Mode**.
- In the menu **Mode** select the desired mode **Heating** or **Ventilation**. ■

Programming

For the programming of the auxiliary heating (auxiliary heating and ventilation) in the menu **Aux. heating** there are three pre-set times:

- **Starting time 1**
- **Starting time 2**
- **Starting time 3**

In each pre-set time, the day and the time (hour and minute) can be set for switching on the auxiliary heating and/or ventilation.

An empty position can be found between Sunday and Monday when selecting the day. If this empty position is selected, the activation is performed without taking into account the day.

If you leave the pre-set menu by selecting the menu **Back** or do not make changes on the display for longer than 10 seconds, the set values are stored, but the pre-set time is not active.

Both other pre-set times can be programmed and stored in the same way. ▶

Only one programmed pre-set time can be active.

The last programmed pre-set time remains active.

After the auxiliary heating activates at the set time, it is necessary to pre-set a time again.

Changing the active pre-set time is carried out after selecting the menu point **Activate** in the menu **Aux. heating** by selecting a pre-set time.

The prerequisite for the correct switching on of the auxiliary heating (auxiliary heating and ventilation) according to the programmed pre-set time is the correct setting of the current time and the weekday ⇒ page 101.

If the system is running, a warning light in the button for direct switching on/off of the auxiliary heating (A) lights up.

The running system deactivates after expiration of the operating period or is deactivated earlier by pressing the button for direct switching on/off of the auxiliary heating (A) ⇒ page 101.

A random pre-set time can be deactivated by selecting the menu point **Deactivate** in the menu **Activate**.

After selecting the menu **Factory setting** in the menu **Aux. heating**, it is possible to return to the factory setting. ■

Radio remote control

The auxiliary heating (auxiliary heating and ventilation) can be switched on or off with the remote control.

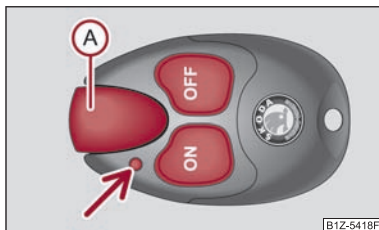

Fig. 110 Auxiliary heating: Radio remote control

- For switching on, press the button (ON).
- For switching off, press the button (OFF).

The transmitter and the battery are housed in the housing of the remote control. The receiver is located in the interior of the car.

If the battery is properly charged, the effective range is up to 600 m. For switching on or off the auxiliary heating, hold the remote control vertically with the antenna (A) ⇒ fig. 110 towards the top. You must not cover over the antenna with the fingers or the palm of the hand. Obstacles between the radio remote control and the vehicle, bad weather conditions and a weaker battery can clearly reduce the range.

The auxiliary heating can only be switched on or off with the radio remote control, if the distance between the radio remote control and the vehicle is at least 2 m.

Warning light in the radio remote control

The warning light in the radio remote control ⇒ fig. 110 indicates after a keystroke if the remote control signal was received by the auxiliary heating and if the battery is adequately charged.

Display warning light	Importance
Lights up green for 2 seconds.	The auxiliary heating was switched on.
Lights up red for 2 seconds.	The auxiliary heating was switched off.
Slowly flashes green for 2 seconds.	The ignition signal was not received.
Quickly flashes green for 2 seconds.	The auxiliary heating is blocked, e. g. because the tank is nearly empty or there is a fault in the auxiliary heating.
Flashes red for 2 seconds.	The switch off signal was not received.
Lights up orange for 2 seconds, then green or red.	The battery is weak, however the switching on or off signal was received.
Lights up orange for 2 seconds, then flashes green or red.	The battery is weak, however the switching on or off signal was not received.
Flashes orange for 5 seconds.	The battery is discharged, however the switching on or off signal was not received.

⚠ Caution

There are electronic components in the radio remote control, protect the remote control against water, severe shocks and direct sun rays. ■

Changing the battery of the radio remote control

If the warning light of the radio remote control indicates a weak or discharged battery, ⇒ page 102, fig. 110, it must be replaced. The battery is located under a cover on the back of the radio remote control.

- Place a coin into the gap of the battery cover and by turning to the left, unlock the cover.
- Change the battery, insert the cover and lock it by turning to the right.



For the sake of the environment

Dispose of a used battery in accordance with environmental regulations.



Note

- Pay attention to the correct polarity when changing the battery.
- The replacement battery must have the same specification as the original battery. ■

Starting-off and Driving

Setting steering wheel position

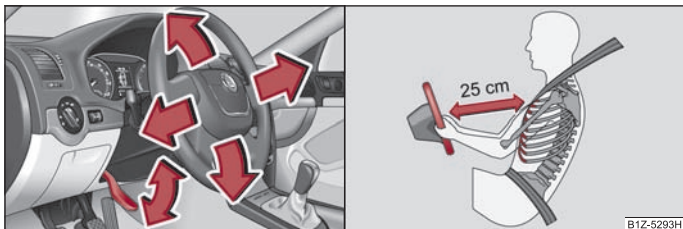

Fig. 111 Adjustable steering wheel: Lever below the steering wheel/safe distance to the steering wheel

You can set the height and the forward/back position of the steering wheel to the desired position.

- Adjust the driver seat ⇒ page 11.
- Pull the lever below the steering wheel down ⇒ fig. 111 - left ⇒ ⚠.
- Set the steering wheel to the desired position (concerning height and forward/back position).
- Push the lever upwards as far as the stop.

⚠ WARNING

- You must not adjust the steering wheel when the vehicle is moving!
- The driver must maintain a distance of at least 25 cm to the steering wheel ⇒ fig. 111 - right. Not maintaining this minimum distance will mean that the airbag system will not be able to properly protect you - hazard!
- For safety reasons the lever must always be firmly pushed up to avoid the steering wheel altering its position unintentionally when driving - risk of accident!
- If you adjust the steering wheel further towards the head, you will reduce the protection offered by the driver airbag in the event of an accident. Check that the steering wheel is aligned to the chest.

⚠ WARNING (continued)

- When driving, hold the steering wheel with both hands firmly on the outer edge in the 9 o'clock and 3 o'clock position. Never hold the steering wheel firmly in the 12 o'clock position or in another way (e.g. in the middle of the steering wheel or at the inner steering wheel edge). In such cases, injuries to the arms, the hands and the head can occur when the driver airbag is deployed. ■

Ignition lock

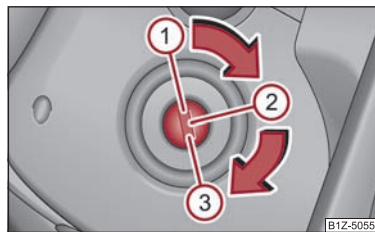

Fig. 112 Ignition lock positions

Petrol engines

- ① - ignition switched off, engine off, the steering can be locked.
- ② - ignition switched on
- ③ - start engine

Diesel engines

- ① - interruption of fuel supply, ignition switched off, engine off, the steering can be locked
 - ② - heating glow plugs on, ignition switched on
- You should not switch on any major electrical components during the heating period otherwise the vehicle battery will be drained unnecessarily.
- ③ - start engine

Applies to all models:

Position ①

To **lock the steering**, with the ignition key withdrawn, turn the steering wheel until the steering locking pin is heard to engage. You should always lock the steering as a general rule if you leave your vehicle. This acts as a deterrent against possible theft of your vehicle ⇒ .

Position ②

Move the steering wheel back and forward a little if the ignition key cannot, or cannot easily be turned into this position, in order to release the steering lock.

Position ③

The engine is started in this position. At the same time switched on low beam or main beam or other electrical components with major power consumption are briefly switched off. The ignition key moves back into position ② when one releases the key.

The ignition key must be turned back into position ① each time before starting the engine again. The starter repeat lock in the ignition lock prevents the starter being engaged when the engine is running and thus getting damaged.

Ignition key withdrawal lock (automatic gearbox)

You can only withdraw the ignition key after switching off the ignition if the selector lever is in position P.

WARNING

- When driving, the ignition key must always be in the position ② (ignition switched on) without the engine running. This position is indicated by the warning lights coming on. If this is not the case, it could result in unexpected locking of the steering wheel - risk of accident!
- Only remove the ignition key from the ignition lock when the vehicle has come to a standstill (by applying the handbrake or moving the selector lever into the position P). The steering lock can engage immediately - risk of accident!
- Always withdraw the ignition key if you are going to leave the vehicle, even for a short time. This is particularly important if children are left in the vehicle. The children might otherwise start the engine or switch on electrical equipment (e.g. power windows) - risk of accident or injury! ■

Starting the engine

General

You can only start the engine only using an original ignition key.

Manual gearbox

- Place the gearshift lever into neutral and put on the handbrake firmly before starting the engine.
- Engage the clutch pedal and keep it depressed until the engine starts.

If you start the engine without depressing the clutch pedal, the engine does not start and the following message appears in the Information display **Depress clutch!** or **CLUTCH** in the display of the instrument cluster.

- Let go of the key as soon as the engine starts otherwise there may be damage to the starter.

Automatic gearbox

- Place the gearshift lever into **P** or **N** before starting the engine, and apply the handbrake firmly.
- Let go of the key as soon as the engine starts otherwise there may be damage to the starter.

The engine running noises may louder at first be louder for a short time after starting the cold engine until oil pressure can be built up in the hydraulic valve clearance compensation. This is quite normal and is not an operating problem.

If the engine does not start ...

You can use the battery of another vehicle as a jump-start aid ⇒ page 213.

WARNING

- Never run the engine in non ventilated or enclosed areas. The exhaust gases of the engine contain besides the odorless and colourless carbon monoxide a poisonous gas - hazard! Carbon monoxide can cause unconsciousness and death.
- Never leave your vehicle unattended with the engine running. ▶

⚠ Caution

- The starter may only be operated (ignition key position ③), if the engine is not running. If the starter is immediately operated after switching off the engine, the starter or the engine can be damaged.
- Avoid high engine revolutions, full throttle and high engine loads as long as the engine has not yet reached its normal operating temperature - risk of damaging the engine!
- Do not tow start the engine - danger of damaging the engine. On vehicles with a catalytic converter, unburnt fuel may get into the catalytic converter where it may ignite. This in turn may damage or destroy the catalytic converter. You can use the battery of another vehicle as a jump-start aid ⇒ page 213, "Jump-starting".



For the sake of the environment

Never warm up the engine when the vehicle is standing. Drive off right away. Through this the engine reaches its operating temperature more rapidly and the pollutant emissions are lower. ■

Petrol engines

These engines are fitted with a starter system which selects the correct fuel-air mixture for every external air temperature.

- Do not operate accelerator before and when starting engine.
- Interrupt the attempt at starting after 10 seconds if the engine does not start right away and wait for about 30 seconds before repeating the attempt.
- It is possible that the fuse on the electrical fuel pump is defect if the engine still does not start. Check the fuse and replace it if necessary ⇒ page 217.
- Contact the nearest specialist garage to obtain professional assistance.

It may be necessary, if the engine is **very hot**, to slightly depress the accelerator after the engine has started. ■

Diesel engines

Glow plug system

Diesel engines are equipped with a glow plug system, the preglow period being controlled automatically in line with the coolant temperature and outside temperature.

The preglow indicator light  comes on after the ignition has been switched on.

You should not switch on any major electrical components during the heating period otherwise the vehicle battery will be drained unnecessarily.

- You should start the engine immediately after the glow plug warning light  has gone out.
- The glow plug warning light will come on for about one second if the engine is at a normal operating temperature or if the outside temperature is above +5 °C. This means that you can start the engine **right away**.
- Interrupt the attempt at starting after 10 seconds if the engine does not start right away and wait for about 30 seconds before repeating the attempt.
- It is possible that the fuse on the diesel preglow system is defect if the engine still does not start. Check the fuse and replace it if necessary ⇒ page 217.
- Contact the nearest specialist garage to obtain professional assistance.

Starting the engine after the fuel tank has run dry

It may take longer than normal to start the engine after refuelling if the fuel tank has run completely dry - up to one minute. This is because the fuel system must first of all be filled while the attempting to start the engine. ■

Switching off the engine

- The engine can be switched off by turning the ignition key into position ① ⇒ page 104, fig. 112.



WARNING

- **Never switch off the engine before the vehicle is stationary - risk of accident!**
- **The brake booster only operates when the engine is running. Greater physical effort for braking is required when engine is switched off. Because if you do not stop as normal, this can cause an accident and severe injuries.**

⚠ Caution

you should not switch the engine off right away at the end of your journey after the engine has been operated for a lengthy period at high loads but should be allowed it to run at idling speed for about 2 minutes. This prevents any accumulation of heat when the engine is switched off.



Note

- The radiator fan may continue running for a further 10 minutes or so after the engine and the ignition have been switched off. The coolant fan may, however, also ▶

switch on again after some time if the coolant temperature rises because of an accumulation of heat in the engine or if the engine is warm and the engine compartment is additionally heated by strong sunlight.

- This is why particular care is required when carrying out any work in the engine compartment ⇒ page 188, "Working in the engine compartment". ■

Shifting (manual gearbox)



Fig. 113 The shift pattern: 5-speed or 6-speed manual gearbox

Shift into reverse only when the car is stationary. Depress the clutch pedal and hold it fully depressed. Wait a moment before engaging reverse gear in order to avoid any shift noises.

The reversing lights will come on once reverse gear is engaged, provided the ignition is on.

WARNING

Never engage the reverse gear when driving - risk of accident!

Note

- One should not lay the hand on the shift lever while driving the vehicle. The pressure of the hand will be transferred to the gearshift forks in the gearbox. This can, over a period of time, lead to early wear of the gearshift forks.
- Depress the clutch pedal fully when changing gears, in order to avoid unnecessary wear and damage. ■

Handbrake

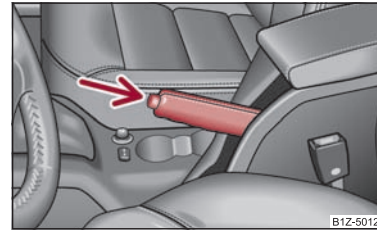



Fig. 114 Centre console: Handbrake

Applying the handbrake

- Pull the handbrake lever up fully.

Releasing the handbrake

- Pull the handbrake lever up slightly and **at the same time** press in the locking button ⇒ fig. 114.
- Hold the button pressed and push the handbrake lever down fully ⇒ .

The handbrake warning light  lights up when the handbrake is applied, provided the ignition is on.

A warning signal sounds and the following text appears in the Information display if you have inadvertently driven off with the handbrake applied:

Release parking brake!

The handbrake warning is activated if you drive at a speed of more than 6 km/h for more than 3 seconds.

WARNING

- Please note that the handbrake must be fully released. A handbrake which is only partially released can result in the rear brakes overheating which will have a negative effect on the operation of the brake system - risk of accident! In addition this can result in premature wear of the rear brake pads.
- Never leave children unattended in the vehicle. The children might, for example, release the handbrake or take the vehicle out of gear. The vehicle might then move off - risk of accident!

⚠ Caution

After the car has come to a stop, always first of all apply the handbrake firmly before then additionally engaging a gear (manual gearbox) or moving the selector lever into position **P** (automatic gearbox). ■

Rear parking aid

The parking aid provides a warning of obstacles behind the vehicle.

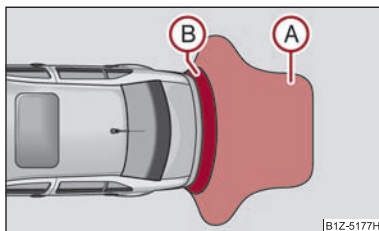

Fig. 115 Parking aid: Detection range of rear sensors

The audible parking aid determines the distance from the rear bumper to an obstacle behind the car with the aid of ultrasound sensors. The tones of the parking aid can be adapted in the menu of the Information display ⇒ page 24. The sensors are integrated in the rear bumper.

Range of sensors

The clearance warning begins at a distance of about 160 cm from the obstacle (area **A** ⇒ fig. 115). The interval between the warning signals becomes shorter as the clearance is reduced.

A continuous tone sounds from a distance of approx. 30 cm (area **B**) - danger area. **You should not reverse any further after this signal sounds!** If the vehicle is equipped with a factory-fitted towing device, the border of the danger area starts - continuous tone - 5 cm further behind the vehicle. The vehicle can be extended through an installed detachable towing device.

On factory-fitted radio navigation systems and car stereos, the distance to the obstruction can also be shown graphically in the display. On vehicles with a factory-fitted towing device, the rear sensors are deactivated when towing a trailer. The driver is informed about this by a graphic display (vehicle towing a trailer) in the radio or the radio navigation display. The factory-fitted radio or navigation system can be set so that the play function volume decreases when activating the parking

aid, see Owner's Manual radio or radio navigation system. This improves the audibility of the parking aid.

Activating

The parking aid is activated automatically when **reverse gear** is engaged and the ignition is turned on. This is confirmed by a brief audible signal.

Deactivating

The parking aid is deactivated by removing the reverse gear.

⚠ WARNING

- The parking aid is not a substitute for the driver paying proper attention and it is always the driver's responsibility to take care when parking the vehicle or carrying out similar manoeuvres.
- You should therefore satisfy yourself, before reversing, that there is no small obstacle, such as a rock, thin post, trailer drawbar etc., behind your vehicle. Such an obstacle might not be within the range detected by the sensors.
- Under certain circumstances, surfaces of certain objects and types of clothing cannot reflect the signal of the parking aid. Thus, these objects or people who wear such clothing are not recognised by the sensors of the parking aid.

i Note

- The parking aid does not operate if you are towing a trailer (applies to models which feature a factory-fitted towing device).
- If a warning signal sounds for about 3 seconds after switching the ignition on and engaging reverse gear, and there is no obstacle close to your car, this indicates a system fault. Have the fault rectified by a specialist workshop.
- The sensors must be kept clean and free of ice to enable the parking aid to operate properly. ■

Front and rear parking aid

The parking aid provides a warning of obstacles in front and behind the vehicle.

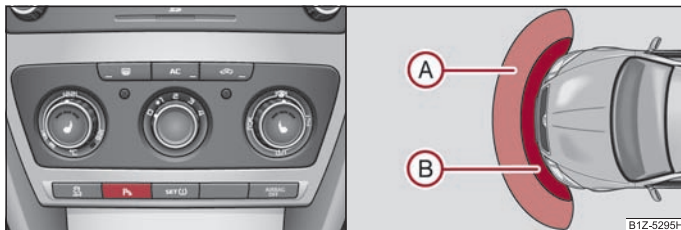

Fig. 116 Activating the parking aid/detection range of the front sensors

The audible parking aid determines the distance between the front or rear bumper and an obstacle with the aid of ultrasound sensors. The sensors are integrated in the front and rear bumper. The signal tones for the front parking aid sound higher as standard than for the rear parking aid. The tones of the parking aid can be adapted in the menu of the Information display ⇒ page 24.

Range of sensors

The distance warning begins at a distance of about 120 cm from the obstacle in front of the vehicle (area A ⇒ fig. 116) and about 160 cm from the obstacle behind the vehicle (area B ⇒ page 108, fig. 115). The interval between the warning signals becomes shorter as the clearance is reduced.

A continuous tone sounds from a distance of approx. 30 cm (area B) - danger area. **From this moment on do not continue driving!** If the vehicle is equipped with a factory-fitted towing device, the border of the danger area starts - continuous tone - 5 cm further away from the vehicle. The vehicle can be extended through an installed detachable towing device.

On factory-fitted radio navigation systems and car stereos, the distance to the obstruction can also be shown graphically in the display. On vehicles with a factory-fitted towing device, the rear sensors are deactivated when towing a trailer. The driver is informed about this by a graphic display (vehicle towing a trailer) in the radio or the radio navigation display. The factory-fitted radio or navigation system can be set so that the play function volume decreases when activating the parking aid, see Owner's Manual radio or radio navigation system. This improves the audibility of the parking aid.

Activating

The parking aid is activated when the **reverse gear** is engaged and the ignition is switched on or by pressing the button ⇒ fig. 116 - left, the symbol P with a car icon lights up in the button. The activation is confirmed by a brief acknowledgement signal.

Deactivating

The parking aid is deactivated after pressing the button (P with a car icon) ⇒ fig. 116 - left, or at a speed of more than 10 km/h - the symbol P with a car icon in the button is no longer illuminated.

! WARNING

- The parking aid is not a substitute for the driver paying proper attention and it is always the driver's responsibility to take care when reversing the vehicle or carrying out similar manoeuvres.
- You should therefore satisfy yourself, before reversing, that there is no small obstacle, such as a rock, thin post, trailer drawbar etc., in front or behind your vehicle. Such an obstacle might not be within the range detected by the sensors.
- Under certain circumstances, surfaces of certain objects and types of clothing cannot reflect the signal of the parking aid. Thus, these objects or people who wear such clothing are not recognised by the sensors of the parking aid.

i Note

- Only the front parking aid operates if you are towing a trailer (applies only to models which feature a factory-fitted towing device).
- If a warning signal sounds for about 3 seconds after activating the system and there is no obstacle close to your car, this indicates a system fault. The fault is confirmed additionally when the symbol P with a car icon flashes in the button ⇒ fig. 116 - left. Have the fault rectified by a specialist workshop.
- The sensors must be kept clean and free of ice to enable the parking aid to operate properly.
- If the parking aid is activated and the selector lever of the automatic gearbox is in the position P, warning signal indicates interruption (vehicle can no longer move). ■

Cruise control system (CCS)

Introduction

The cruise control system (CCS) maintains a constant speed, more than 30 km/h (20 mph), once it has been set, without you having to depress the accelerator pedal. This is only possible within the range which is permitted by the power output and braking power of the engine. The cruise control system makes it possible - particularly on long journeys - for you to rest your "accelerator foot".

WARNING

- For safety reasons, the cruise control system must not be used in dense traffic or on unfavourable road surfaces (such as icy roads, slippery roads, loose gravel) - risk of accident!
- In order to prevent unintentional use of the cruise control system, always switch off the system after use.

Note

- Models fitted with a manual gearbox: Always depress the clutch pedal if you switch on the cruise control system when the gearbox is in Neutral! Otherwise the engine can rev up unintentionally.
- The cruise control system is not able to maintain a constant speed when driving on steep downhill sections. The weight of the vehicle increases the speed at which it travels. One should shift down in good time to a lower gear or slow the vehicle down by applying the foot brake.
- It is not possible on vehicles fitted with an automatic gearbox to switch on the cruise control system if the selector lever is in the position **P**, **N** or **R**. ■

Storing a speed

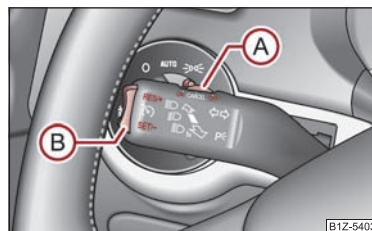

Fig. 117 Operating lever: Rocker button and switch of the cruise control system

The cruise control system is operated by means of the switch **(A)** ⇒ fig. 117 and the rocker button **(B)** in the left lever of the multi-functional switch.

- Press the switch **(A)** into the position **ON**.
- After the desired speed has been reached, press the rocker button **(B)** into the **SET** position.

After you have released the rocker button **(B)** out of the position **SET**, the speed you have just stored is maintained at a constant speed without having to depress the accelerator.

You can **increase** the speed by depressing the accelerator. Releasing the accelerator will cause the speed to **drop** again to the set speed.

This does not apply, however, if you drive at a speed which is more than 10 km/h higher than the saved speed for a period of more than 5 minutes. The stored speed will be cancelled in the memory. You then have to re-store the desired speed.

One can **reduce** the speed in the usual manner. The system is switched off temporarily by actuating the brake or clutch pedal ⇒ page 111.

WARNING

First ensure that it is not too high for the traffic conditions which exist at that moment before resuming the stored speed. ■

Changing a stored speed

You can also change the speed of the vehicle without depressing the accelerator.

Faster

- You can **increase** the stored speed without depressing the accelerator, by pressing the rocker button (B) ⇒ page 110, fig. 117 in the **RES** position.
- The speed of the car will increase continuously if you hold the rocker button pressed in the **RES** position. Once the car has reached the desired speed, release the rocker button. The set speed is then stored in the memory.

Slower

- You can **decrease** the stored speed by pressing the rocker button (B) in the **SET** position.
- Holding down the rocker button pressed in the **SET** position will cause the speed of the vehicle to reduce continuously. Once the car has reached the desired speed, release the rocker button. The set speed is then stored in the memory.
- If you release the rocker button when the car is travelling at a speed of less than 30 km/h, the speed is not stored, the memory is erased. It is then necessary to again store the speed with the rocker button (B) in the position **SET** after an increase in speed of the vehicle to more than 30 km/hour. ■

Switching off the cruise control system temporarily

- You can **switch off** the cruise control system **temporarily** by depressing the brake pedal or clutch pedal, on vehicles fitted with an automatic gearbox only with the brake pedal.
- You can switch off temporarily the cruise control system, if you press the switch (A) in the middle position.

The set speed remains stored in the memory.

The **Resumption** of the stored speed is achieved by releasing the brake or clutch pedal, on vehicles fitted with automatic gearbox only after releasing the brake pedal and after shortly pressing the rocker button (B) ⇒ page 110, fig. 117 into the position **RES**.

WARNING

First ensure that it is not too high for the traffic conditions which exist at that moment before resuming the stored speed. ■

Switching off the cruise control system completely

- Press the switch (A) ⇒ page 110, fig. 117 to the right into position **OFF**. ■

"(START-STOP)"



Fig. 118 Dash panel: START-STOP System button

The "START-STOP" system helps you to save fuel while at the same time reducing harmful exhaust emissions and CO₂ emissions.

The function is automatically activated each time the ignition is switched on.

In the start-stop mode, the engine automatically switches to the vehicle's idle phase, e.g. when stopped at traffic lights.

Information regarding the current state of the "START-STOP" system is indicated in the display of the instrument cluster.

Automatic engine shut down (stop phase)

- Stop the vehicle (where necessary, apply the handbrake).
- Take the vehicle out of gear.
- Take your foot off the clutch.

Automatic engine restart (start phase).

- Push down on the clutch. ▶

Switching the "START-STOP" system on and off

You can switch the "START STOP" system on/off by pressing the button → page 111, fig. 118.

When start-stop mode is deactivated, the warning light in the button lights up.

If the vehicle is in the stop phase when manually switching off the system, the engine starts immediately.

The "START-STOP" system is very complex. Some of the procedures are hard to check without servicing. The general conditions for the proper functioning of the "START-STOP" system are listed in the following overview.

Conditions for the automatic engine shut down (stop phase)

The gearshift lever is in Neutral.

The clutch pedal is not pressed!

The driver has fastened the seat belt.

The driver's door is closed.

The bonnet is closed.

The vehicle is at a standstill.

The factory-fitted towing device is not electrically connected to a trailer.

The engine has reached its operating temperature.

The charge state of the vehicle battery is sufficient.

The stationary vehicle is not on a steep slope or a steep downhill section.

The engine speed is less than 1200 1/min.

The temperature of the vehicle battery is not too low or too high.

The pressure in the brake system is sufficient.

The difference between the outdoor- and the set temperature in the interior is not too great.

The vehicle speed since the last time the engine was switched off was greater than 3 km/h.

No cleaning of the diesel particle filter takes place. → page 28

The front wheels are not turned excessively (the steering angle is less than 3/4 of a steering wheel revolution).

Conditions for an automatic restart (start phase)

The clutch is pressed.

The max./min. temperature is set.

The Defrost function for the windscreen is switched on.

A high blower stage has been selected.

The "START STOP" button is pressed.

Conditions for an automatic restart without driver intervention

The vehicle moves at a speed of more than 3 km/h.

The difference between the outdoor- and the set temperature in the interior is too great.

The charge state of the vehicle battery is not sufficient.

The pressure in the brake system is not sufficient.

Messages in the instrument cluster display (valid for vehicles without Information display)

ERROR: START STOP	Error in the START-STOP system
START STOP NOT POSSIBLE	Automatic engine shut down is not possible
START STOP ACTIVE	Automatic engine shut down (stop phase)
SWITCH OFF IGNITION	Switch off the ignition
START MANUALLY	Start the engine manually



WARNING

- The brake servo unit and power steering only operate if the engine is running.
- Never let the vehicle roll with the engine switched off.

 **Caution**

If the "START-STOP" system is used at very high outside temperatures over a very long period of time, the vehicle battery can be damaged.

 **Note**

- Changes to the outdoor temperature can have an effect on the internal temperature of the vehicle battery even after several hours. If the vehicle remains outdoors for a long time in minus temperatures or in direct sunlight, it can take several hours until the internal temperature of the vehicle battery reaches a suitable temperature for proper operation of the "START STOP" system.
- In some instances it may be necessary to start the engine manually with the ignition key (e.g. when the seat belt is not inserted or the driver's door is opened for more than 30 seconds). Follow the messages in the instrument cluster display.
- If the air conditioning Climatronic is running in automatic mode, under certain conditions, the engine may not switch off automatically. ■

Automatic gearbox

Automatic gearbox

Information for driving with the 6-speed automatic gearbox

The maximum speed is reached in the 5th gear. The 6th gear serves as an economic driving programme, which is intended to reduce the fuel consumption. Shifting up and down through the gears is performed automatically. You can also, however, switch the gearbox over into the **Tiptronic mode**. This mode makes it possible for you to also shift gears manually ⇒ page 117.

Starting-off and Driving

- Depress the brake pedal fully and keep it depressed.
- Press the Shiftlock button (button in handle of the selector lever), move the selector lever into the desired position, e.g. **D** ⇒ page 115, and then release the Shiftlock button.
- Wait a moment until the gearbox has shifted (a slight engagement nudge can be felt).
- Release the brake pedal and depress the accelerator ⇒ .

Stop

- The selector lever position **N** does not have to be selected when stopping just for a short time, such as at a cross roads. It is absolutely sufficient to hold the stopped vehicle stationary by depressing the foot brake. The engine can, however, be allowed just to idle.

Parking

- Depress the brake pedal and hold it depressed.
- Apply the handbrake firmly.
- Press and Shiftlock button in the selector lever, move the selector lever to **P** and then release the Shiftlock button.

The engine can only be **started** when the selector lever is in position **P** or **N**. If the selector lever is not in the **P** or **N** positions when locking the steering, switching the ignition on or off or when leaving the engine on, the following message will appear in the Information display **Move selector lever to position P/N!** or, in the instrument cluster display → **P/N**.

It is sufficient to engage selector lever position **P** when parking on a flat surface. When parking on a slope you should first apply the handbrake firmly and then move the selector lever into position **P**. This is to ensure that there is no excessive pressure acting on the lock mechanism and that it is easier to subsequently move the selector lever out of position **P**. If the selector lever is not in the **P** position when the driver's door is open and the ignition is switched off, or if it is not in the **P** position when the ignition is switched off and the driver's door is opened, the following message will appear in the Information display **Move selector lever to position P!** or, in the instrument cluster display → **P**. The message disappears after a few seconds by switching on the ignition or by moving the selector lever into the position **P**.

If the selector lever position **N** is selected by accident while driving it is first necessary to release pressure on the accelerator pedal and wait for idling speed of the engine to be reached before engaging a drive position in the selector lever.



WARNING

- Do not depress the accelerator when changing the position of the selector lever if the car is stationary and the engine is running - risk of accident!
- Never move the selector lever into position **R** or **P** when driving - risk of an accident!
- When the engine is running and the vehicle is stationary, it is necessary to hold the car with the brake pedal in all the positions of the selector lever (except **P** and **N**) since the power transmission is never completely interrupted, also not when the engine is idling - the vehicle creeps. ■

Information for driving with the automatic gearbox DSG

The abbreviation DSG means Direct shift gearbox (Direct shift gearbox).

Two independent clutches are needed for the power transmission between the engine and the gearbox. These replace the torque converter of the conventional automatic gearbox. Their shifting is matched in such a way that there are no jerks when shifting the gear and the power transmission of the engine to the front wheels is not interrupted. Shifting up and down through the gears is performed automatically. You can also, however, switch the gearbox over into the **Tiptronic mode**. This mode makes it possible for you to also shift gears manually ⇒ page 117. ►

Starting-off and Driving

- Depress the brake pedal fully and keep it depressed.
- Press the Shiftlock button (button in handle of the selector lever), move the selector lever into the desired position, e.g. **D** → page 115, and then release the Shiftlock button.
- Release the brake pedal and depress the accelerator → ⚠️.

Stop

- The selector lever position **N** does not have to be selected when stopping just for a short time, such as at a cross roads. It is absolutely sufficient to hold the stopped vehicle stationary by depressing the foot brake. The engine can, however, be allowed just to idle.

Parking

- Depress the brake pedal and hold it depressed.
- Apply the handbrake firmly.
- Press and Shiftlock button in the selector lever, move the selector lever to **P** and then release the Shiftlock button.

The engine can only be **started** when the selector lever is in position **P** or **N**. If the selector lever is not in the **P** or **N** positions when locking the steering, switching the ignition on or off or when leaving the engine on, the following message will appear in the Information display **Move selector lever to position P/N!** or, in the instrument cluster display → **P/N**. At temperatures below -10 °C the engine can only be started in the selector lever position **P**.

It is sufficient to engage selector lever position **P** when parking on a flat surface. When parking on a slope you should first apply the handbrake firmly and then move the selector lever into position **P**. This is to ensure that there is no excessive pressure acting on the lock mechanism and that it is easier to subsequently move the selector lever out of position **P**. If the selector lever is not in the **P** position when the driver's door is open and the ignition is switched off, or if it is not in the **P** position when the ignition is switched off and the driver's door is opened, the following message will appear in the Information display **Move selector lever to position P!** or, in the instrument cluster display → **P**. The message disappears after a few seconds by switching on the ignition or by moving the selector lever into the position **P**.

If the selector lever position **N** is selected by accident while driving it is first necessary to release pressure on the accelerator pedal and wait for idling speed of the engine to be reached before engaging a drive position in the selector lever.

⚠️ WARNING

- Do not depress the accelerator when changing the position of the selector lever if the car is stationary and the engine is running - risk of accident!
- Never move the selector lever into position **R** or **P** when driving - risk of an accident!
- If you are stopping at a hill (downhill section), never try to hold the car stationary with the gear engaged by means of the "accelerator", this means by letting the clutch slip. This can lead to overheating of the clutch. If there is a risk of overheating of the clutch due to overload, the clutch is opened automatically and the vehicle rolls backward - risk of accident!
- If you must stop at a slope, depress and hold the brake pedal, so that you can prevent the vehicle from rolling back.

⚠️ Caution

- The double clutch on the automatic gearbox DSG is equipped with an overload protection. If you make use of the uphill function on a vehicle which is stationary or driving slowly uphill, it will result in an increase of thermal stress of the clutches.
- In the event that they overheat, the symbol ⚠️ appears in the information display with the warning text → page 34. In such a case bring the vehicle to a stop, switch off the engine and wait until the warning light and the warning go out - risk of gearbox damage! You can continue the trip as soon as the symbol and the warning go out. ■

Selector lever positions

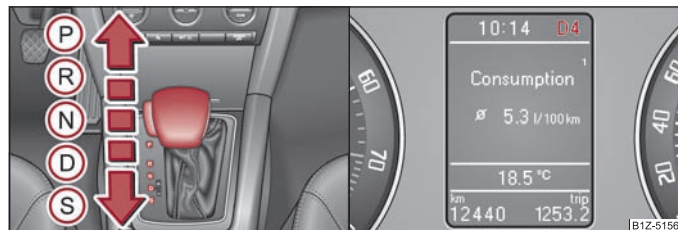



Fig. 119 Selector lever/information display: Selector lever positions

The current selector lever position is indicated in the information display of the instrument cluster ⇒ page 115, fig. 119 - right. In the positions **D** and **S** the gear you have already engaged will be additionally displayed on the display.

P - Parklock

The driven wheels are locked mechanically in this position.

The Parklock must only be engaged when the vehicle is stationary ⇒ .

If you wish to move the selector lever into or out of this position, you must press the Shiftlock button in the handle of the selector lever and at the same time depress the brake pedal.

If the battery is used, the selector lever cannot be moved out of the position **P**.

R - Reverse gear

Reverse gear must only be engaged when the vehicle is stationary and the engine idling ⇒ .

The brake pedal must be depressed and at the same time the Shiftlock must be pressed, if you wish to obtain the selector lever positions **R**, **P** or **N**.

When the ignition is switched on and the selector lever is in position **R**, the reverse lights will come on.

N - Neutral

The transmission is in Neutral in this position.

The brake pedal must be depressed (if the lever is in its position for longer than 2 seconds) in order to move the selector lever out of the position **N** into the position **D** or **R**, with the ignition switched on, on a vehicle travelling at less than 5 km/hour or on a stationary vehicle.

D - Position for driving forward

When the selector lever is in this position, the forward gears are shifted up and down automatically in line with engine load, vehicle speed and the dynamic shift programme.

You must depress the brake pedal if you wish to move into position **D** from **N** when the vehicle is travelling at less than 5 km/hour or is stationary ⇒ .

In certain circumstances (e.g. when driving in mountainous regions or when towing a trailer) it may be beneficial to select the manual shift programme ⇒ page 117 for a short time in order to adapt the gearbox ratios manually to the driving situations.

S - Position for sporty style of driving

Shifting up later into a higher gear makes it possible to fully exploit the power potential of the engine. The gearbox also then shifts down at higher engine speeds as in the position **D**.

The gearbox does not shift into the 6th gear in the position **S**, because the maximum speed is reached with the 5th gear⁹⁾.

The Shiftlock on the selector lever grip must be pressed when moving the selector lever out of the position **D** into the position **S**.



WARNING

- Never move the selector lever into position **R** or **P** when driving - risk of an accident!
- When the engine is running and the vehicle is stationary, it is necessary to hold the car with the brake pedal in all the positions of the selector lever (except **P** and **N**) since the power transmission is never completely interrupted, also not when the engine is idling - the vehicle creeps.
- You must on no account unintentionally operate the throttle (e.g. by hand from the engine compartment) if a drive position is engaged when the car is stationary. The vehicle would otherwise immediately start off - also when the handbrake is firmly applied - risk of an accident!
- You must move the selector lever into position **P** and firmly apply the handbrake first before you or any other person opens the bonnet and starts working on the engine when it is running - risk of accident! It is also essential to observe all warnings ⇒ page 188, "Working in the engine compartment". ■

Selector lever lock

Automatic selector lever lock

With the ignition on, the selector lever is locked when it is in the positions **P** and **N**. You must first of all depress the brake pedal in order to move the selector lever out of this position. The warning light  ⇒ page 31 lights up in the instrument cluster as a reminder for the driver when the selector lever is in the positions **P** and **N**.

A time delay element ensures that the selector lever is not blocked when rapidly switching over the position **N** (e.g. from **R** to **D**). This does, for example, allow one to see saw out a stuck vehicle. The selector lever lock will click into place if the lever is in the **N** position for more than 2 seconds without the brake pedal being pressed. ►

⁹⁾ Not valid for vehicles with automatic gearbox DSG.

The selector lever lock is only active if the vehicle is stationary or moving at speed of less than 5 km/hour. The lock is switched off automatically into position **N** when the car is travelling at a higher speed.

Shiftlock button

The Shiftlock button in the handle of selector lever prevents certain selector lever positions being engaged inadvertently. The selector lever lock is cancelled when you press the Shiftlock button.

Keylock - Ignition key withdrawal lock

You can only withdraw the ignition key after switching off the ignition if the selector lever is in position **P**. If the ignition key is withdrawn, the selector lever is blocked in position **P**. ■

Kickdown function

The kickdown function provides you with maximum acceleration power.

Fully depressing the accelerator pedal allows the kickdown function to be activated in the desired driving program. This function has precedence over the driving programme and serves for maximum acceleration of the vehicle when exploiting the maximum power potential of the engine without taking into account the current selector lever position (**D**, **S** or **Tiptronic**). The gearbox shifts down to one or several gears in line with the driving state and the vehicle accelerates. The gearbox does not shift up into the highest gear until the engine has reached its maximum revolutions for this gear range.

WARNING

Please note that using the kickdown function can result in the driven wheels spinning on a smooth or slippery road surface - risk of skidding! ■

Dynamic shift programme

The automatic gearbox of your vehicle is controlled electronically. Shifting up and down through the gears is performed automatically on the basis of pre-defined driving programmes.

Adopting a **moderate style of driving** will cause the gearbox to select the most economical driving programme. Shifting up into a higher gear as soon as possible and shifting down as late as possible will have a favourable effect on your fuel consumption.

Adopting a **sporty style of driving** with rapid movements of the accelerator pedal combined with sharp acceleration and frequent changes in speed, exploiting the top speed of the car or depressing the accelerator pedal (kickdown function), will cause the gearbox to switch over to this style of driving and shift down earlier with frequent changes in gears in comparison to the moderate style of driving.

Selecting the most appropriate driving programme for the particular style of driving is a continuous process. Irrespective of this it is, however, possible to switch or shift down into a dynamic shift programme by depressing the accelerator rapidly. The gearbox shifts down into a lower gear matching the speed of the car and this allows you to accelerate rapidly (e.g. when overtaking) without having to depress the accelerator pedal fully into the kickdown range. The original programme will be reactivated to match your particular style of driving once the gearbox has shifted up again.

When driving in hilly regions, the gears are selected to match uphill and downhill sections. This avoids the gearbox frequently shifting up and down when negotiating an uphill stretch. When driving downhill, it is possible to shift down into the Tiptronic position, in order to exploit the engine brake torque. ■

Tiptronic

The Tiptronic allows the driver to also shift gears manually.

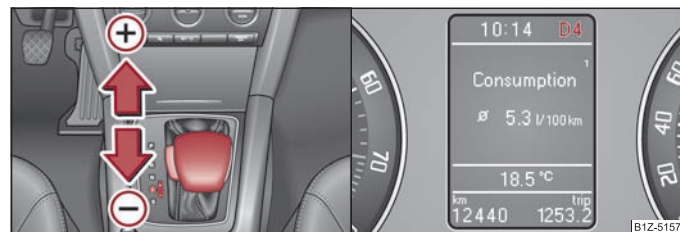

Fig. 120 Selector lever: manual shifting/information display: Manual shifting of gears

The selector lever position you have engaged is indicated in the information display of the instrument cluster together with the engaged gear ⇒ fig. 120 - right.

Switching over to manual shifting

- Push the selector lever to the right out of position **D**. After switching over, the current engaged gear is indicated in the display. ▶

Shifting up gears

- One-touch forward of the selector lever (in the Tiptronic position) ⇒ page 117, fig. 120 (+).

Shifting down gears

- One-touch back of the selector lever (in the Tiptronic position) (-).

It is possible to switch over to manual both when the car is stationary and also when driving.

When you accelerate, the gearbox shifts up automatically into the higher gear just before the maximum permissible engine speed is reached.

If you select a lower gear, the automatic gearbox does not shift down until there is no risk of the engine overrevving.

If you operate the kickdown function, the gearbox shifts into a lower gear in line with the vehicle speed and engine speed. ■

Manual shifting on the multifunction steering wheel



Fig. 121 Multifunction steering wheel: Manual shifting of gears

Switching over to manual shifting

- Push the selector lever to the right out of position D. After switching over, the current engaged gear is indicated in the display.

Shifting up gears

- Press the right rocker switch (+) ⇒ fig. 121 for the multifunction steering wheel.

Shifting down gears

- Press the left rocker switch (-) ⇒ fig. 121 for the multifunction steering wheel.

Temporarily switching over to manual shifting

- If the selector lever is in position D or S, press the left rocker switch (-) or the right rocker switch (+) for the multifunction steering wheel.
- If the rocker switches (-) or (+) are not pressed for some time, the manual shifting switches off. You can also switch off the temporary switch over to manual shifting by pressing the right rocker switch (+) for more than 1 second. ■

Emergency programme

An emergency programme exists in the event of a fault in the system.

The gearbox operates in a corresponding emergency programme if there are functional faults in the gearbox electronics. This is indicated by all of the segments in the display lighting up or going out.

A functional fault can have the following effect:

- The gearbox only shifts into certain gears.
- The reverse gear R cannot be used.
- The manual shift programme (Tiptronic) is switched off in the emergency mode.

If the gearbox has switched over to emergency mode, drive to the nearest specialist garage in order to have the fault rectified. ■

Selector lever-emergency unlocking

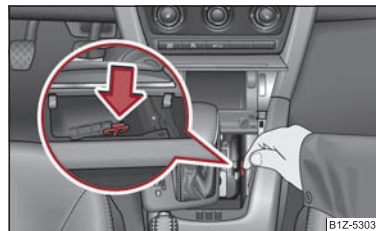

Fig. 122 Selector lever-emergency unlocking

In case of interruption of the power supply (e.g. flat vehicle battery, defective fuse) or defect of the selector lever lock, the selector lever can no longer be shifted from the position **P** in the normal way and the vehicle can no longer be moved. The selector lever must be unlocked in case of emergency.

- Apply the handbrake firmly.
- Open the stowage compartment in front centre console or the front ashtray.
- Carefully pull up the front left and right cover.
- Pull up rear cover.
- Use a finger to press the yellow plastic part in direction of arrow ⇒ page 118, fig. 122.
- Simultaneously press the shiftlock button in the handle of the selector lever and shift the lever into the position **N** (if the selector lever is shifted again into the position **P**, it is once again blocked). ■

Communication

Multifunction steering wheel

Operate radio and radio navigation system on the multifunction steering wheel

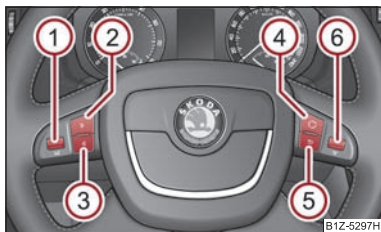

Fig. 123 Multifunction steering wheel:
control buttons

The buttons for setting the basic functions of the factory-fitted radio and radio navigation system are located on the multifunction steering wheel ⇒ fig. 123.

You can of course operate the radio and radio navigation system at the appliance. You will find a description in the relevant Owner's manual.

If the side lights are switched on, the buttons on the multifunction steering wheel are illuminated.

The buttons apply for the respective operating mode of the current radio or radio navigation system.

By pressing or turning the buttons, you can carry out the following functions. ►

Button	Action	Radio, traffic information	CD/CD changer/MP3	Navigation
①	press briefly	Switch off/on tone/activation and deactivation of the voice control ^{a)}		
①	press button for a long period of time	switch off/on		
①	⏮ turn upwards	Increase volume		
①	⏭ turn downwards	Decrease volume		
②	▶ press briefly	Changing to the next stored radio station Changing to the next stored traffic information Interrupting the traffic report	Changing to the next title	
②	▶ press button for a long time	Interruption of the traffic report	fast forward	
③	◀ press briefly	Changing to the previously stored radio station Changing to the previously stored traffic information Interrupting the traffic report	Changing to the previous title	
③	◀ press button for a long time	Interruption of the traffic report	fast rewind	
④	🔄 press briefly	Changing the audio source		
⑤	↶ press briefly	Calling up the main menu		
⑥	press briefly	Interruption of the traffic report	without function	
⑥	△ turn upwards	Display of the stored/accessible stations scroll upwards Interruption of the traffic report	Changing to the previous title	without function
⑥	▽ turn downwards	Display of the stored/accessible stations scroll downwards Interruption of the traffic report	Changing to the next title	

^{a)} Valid for the radio navigation system Columbus.

Note

- The loudspeakers in the vehicle are designed to match the power output of the radio and radio navigation system of 4x 20 W.
- For the equipment sound system, the loudspeakers are matched to a power output of the amplifier of 4x40 W + 6x20 W. ■

Mobile phones and two-way radio systems

The installation of a mobile phone and two-way radio system in a vehicle should be carried out by a specialist garage.

Škoda Auto permits the operation of mobile phones and two-way radio systems with a professionally installed external aerial and a maximum transmission power of up to 10 watts.

It is essential that you inform a specialist garage about the possibilities to assemble and operate mobile phones and two-way radio sets which have a power output of more than 10 W. They will inform you which technical possibilities exist for retrofitting mobile phones.

When using a mobile phone inside the vehicle, which is not inserted into the phone adapter, and thus has no connection to the external aerial, the electromagnetic radiation can exceed the current limit value. If a suitable adapter is available for your mobile phone, use your mobile phone exclusively in the adapter so that the radiation in the vehicle drops to a minimum. This also improves the quality of the connection.

Operation of mobile phones or two-way radio systems may interfere with functioning of the electronic systems of your vehicle. The reasons for this may be:

- no external aerial,
- external aerial incorrectly installed,
- transmission power greater than 10 watts.

WARNING

- **If a mobile phone or a two-way radio system is operated in the vehicle without using an external aerial or an external aerial which has been incorrectly installed, this can increase the strength of the electromagnetic field in the interior of the vehicle.**
- **Please concentrate fully at all times on your driving!**
- **You must not install two-way radio systems, mobile phones or mounts on the covers of the airbags or within the immediate deployment range of airbags. This might result in injuries to the occupants in the event of an accident.**
- **Never leave a mobile phone on a seat, on the dash panel or in another area, from which it can be thrown during a sudden braking manoeuvre, an accident or a collision. In this case, the occupants of the vehicle might be injured.**

Note

Observe the country-specific regulations for the use of mobile phones in vehicles. ■

Universal telephone preinstallation GSM II

Introduction

The universal telephone preinstallation GSM II is a built-in "hands-free system", it provides a voice operated convenience mode via the multifunction steering wheel or the radio navigation system.

All communication between a telephone and the hands-free system of your vehicle can only be established with the help of the Bluetooth® technology. The adapter serves only for charging the telephone and for transmitting the signal to the external aerial of the vehicle.

To ensure an optimum signal transmission, always leave the telephone with the adapter in the telephone mount.

Furthermore the volume can be changed individually during the call at any time with the button for setting the radio or radio navigation system or with the buttons on the multifunction steering wheel.

WARNING

Pay attention primarily to the traffic situation! As the driver you are fully responsible for road safety. Use the telephone system only to such an extent, so that you are in full control of your vehicle at any time.

Note

- Please refer to the following guidelines → page 122, "Mobile phones and two-way radio systems".
- Should you have any questions, please contact an authorised Škoda Service Partner. ■

Phone Phonebook

A phone phonebook is part of the mobile phone preinstallation with voice control. In the phone phonebook there are 2 500 free memory locations available. Each contact can contain up to 4 numbers. This phone phonebook can be used in line with the mobile telephone.

On vehicles fitted with the radio navigation system Columbus, a maximum of 1200 telephone contacts are shown in the display of this appliance.

After the first connection of the telephone, the system begins to load the phone book from the phone and the SIM card into the memory of the control unit. ►

Each time the telephone has established a new connection with the hands-free system, an update of the relevant phone book is performed. The updating can take a few minutes. During this time the phone book, which was stored after the last update was completed, is available. Newly stored telephone numbers are only shown after the updating has ended.

If the number of contacts loaded exceeds 2 500, the phone book is not complete.

If a telephone event (e.g. incoming or outgoing call, dialogue of the voice control) occurs during the updating procedure, the updating is interrupted. After the telephone event has ended, the updating starts anew. ■

Connection of the mobile phone with the hands-free system

In order to connect a mobile phone with the hands-free system, it is necessary to connect the telephone to the hands-free system. Detailed information on this is provided in the operating instructions of your mobile phone. The following steps must be carried out for the connection:

- Activate the Bluetooth® in your telephone and the visibility of the mobile phone.
- Switch on the ignition.
- Select the menu **Phone - Phone search** in the information display and wait until the control unit has ended the search.
- Select your mobile phone in the menu of the units found.
- Confirm the PIN (as standard **1234**).
- If the hands-free system announces (as standard **Skoda UHV**) on the display of the mobile phone, enter the PIN (as standard **1234**) within 30 seconds and wait until the connection is established¹⁰⁾.
- After ending the connection, confirm in the information display that a new user profile was created.

If no more free space is available for creating a new user profile, delete an existing user profile.

If you have not managed to connect your mobile phone with the hands-free system within 3 minutes after switching on the ignition, switch the ignition off and then again on. The visibility of the hands-free system is established again for 3 minutes. The visibility of the Bluetooth® device is automatically switched off if the vehicle starts off or if the mobile phone connects to the device.

¹⁰⁾ Some mobile phones have a menu, in which the authorization for establishing a Bluetooth® connection is performed via the input of a code. If the input for the authorization is necessary, it must always be performed when re-establishing the Bluetooth connection.

During the connecting procedure, no other mobile phone may be connected with the hands-free system.

Up to four mobile phones can be paired to the hands-free system, whereby only one mobile phone can communicate with the hands-free system.

Connection with an already paired mobile phone

After switching on the ignition, the connection is automatically established for the already paired mobile phone¹⁰⁾. Check on the mobile unit if the automatic connection was established.

Disconnecting the connection

- By withdrawing the ignition key.
- By disconnecting the device in the information display.
- By disconnecting the device in the mobile phone.

Solving connection problems

If the system announces **No paired phone found**, check the operating state of the telephone:

- Is the telephone switched on?
- Is the PIN code entered?
- Is Bluetooth® active?
- Is the visibility of the mobile phone active?
- Was the telephone already paired with the hands-free system?



WARNING

In the event of air transport, the Bluetooth® function of the hands-free system must be switched off by a specialist garage!



Note

- Not valid for all mobile phones which enable a communication via Bluetooth®. You can ask at an authorised Skoda Service Partner if your telephone is compatible with the universal telephone preinstallation GSM II.
- If a suitable adapter is available for your mobile phone, use your mobile phone exclusively in the adapter so that the radiation in the vehicle drops to a minimum.
- Inserting the mobile phone into the adapter ensures an optimal sending and receiving power and offers at the same time the advantage of the battery charging.
- The range of the Bluetooth® connection to the hands-free system is restricted to the vehicle interior. The range is dependent on local factors, e.g. obstacles

between the devices and mutual interferences with other devices. If your mobile phone is e.g. in a jacket pocket, this can lead to difficulties when establishing the Bluetooth™ connection with the hands-free system or the data transfer. ■

Inserting the mobile phone and adapter

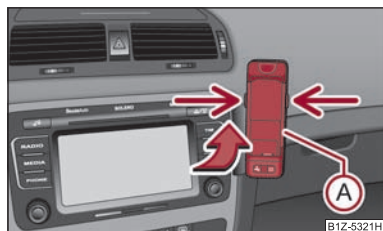

Fig. 124 Universal preparation for the mobile phone

Only one telephone mount is factory-fitted. An adapter for the telephone can be purchased from the range of the Škoda original accessories.

Inserting the mobile phone and adapter

- First of all push the adapter **A** in the direction of arrow ⇒ fig. 124 up to the stop into the mount. Press the adapter slightly downwards, until it locks securely into position.
- Insert the mobile phone into the adapter **A** (as specified in manufacturer's instructions).

Removing the mobile phone and adapter

- Press simultaneously the side locks of the mount ⇒ fig. 124 and remove the mobile phone and adapter.

! Caution

Taking the mobile phone out of the adapter during the call can lead to interruption of the connection. When taking out the mobile phone, the connection to the factory-fitted antenna is interrupted, this reduces the quality of the transmitting and receiving signal. The charging of the mobile phone battery is also interrupted. ■

Operating telephone calls with the aid of the adapter.

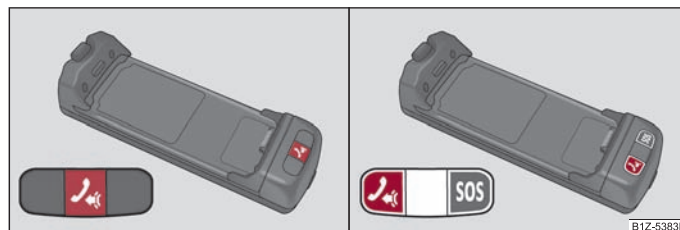

Fig. 125 Illustration image: Single-button adapter/two-button adapter

Function overview of the **PTT** ("push to talk") button on the adapter ⇒ fig. 125:

- Activating/deactivating voice control
- Reject/end a call

On some adapters, aside from the **PTT** button, the **SOS** ⇒ fig. 125 button also appears - on the right. After pressing the button for 2 seconds, the number 112 (Emergency call) is dialed.

i Note

- The adapters illustrated are only prime examples.
- On vehicles fitted with the radio navigation system Columbus, the **PTT** and **SOS** buttons do not operate. ■

Operation of the telephone on the multifunction steering wheel

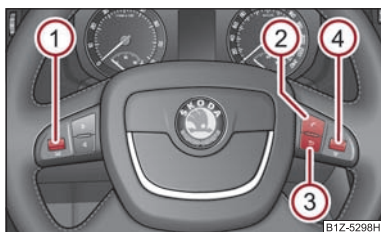

Fig. 126 Multifunction steering wheel: Control buttons for the telephone

The driver can set the basic functions of the telephone by simply operating the buttons located on the steering wheel so that he can concentrate on the traffic situation without being distracted as little as possible by operating the telephone ⇒ fig. 126.

This applies only if your vehicle has been equipped with the telephone preinstallation at the factory.

If the side lights are switched on, the buttons on the multifunction steering wheel are illuminated.

Overview of the different functions in contrast to the multifunction steering wheel without mobile phone operation ⇒ page 120.

Button	Action	Operation
①	press briefly	Activation and deactivation of the voice control (Button PTT - Push to talk) Cancellation of the replayed message
①	↗ turn upwards	Increase volume
①	↘ turn downwards	Decrease volume
②	☎ press briefly	Accept call, end call, entry in the main menu of the telephone, list of the dialed numbers, call the dialed contact
②	☎ press button for a long time	Reject call, private call
③	➡ press briefly	Reach one level higher in the menu (according to the current position in the menu)
③	➡ press button for a long time	Leave the phone menu
④	press briefly	Selection of menu point
④	press button for a long period of time	To the next initial letter in the telephone book
④	△ turn upwards	The last chosen menu selection, name
④	▽ turn downwards	The next menu selection, name
④	△ quickly turn upwards	To the previous initial letter in the telephone book
④	▽ quickly turn downwards	To the next initial letter in the telephone book

The buttons operate the functions for the operating mode of the current telephone. ■

Operate the telephone via the information display

In the menu **Phone** you can select the following menu points:

- **Phone book**
- **Dial number**¹¹⁾
- **Call register**
- **Voice mailbox**
- **Bluetooth**¹¹⁾
- **Settings**¹²⁾
- **Back**

Phone book

In the menu point **Phone book** is the list of the loaded contacts from the telephone memory and the SIM card of the mobile phone.

Dial number

In the menu point **Dial number**, you can write any telephone number. Select in sequence the desired digits with the aid of the handwheel and confirm it by pressing the handwheel. You can choose the numbers **0 - 9**, symbols **+**, *****, **#** and the functions **Cancel**, **Call**, **Delete**.

Call register

In the menu point **Call register**, you can select the following menu points:

- **Missed calls**
- **Dialled numbers**
- **Received calls**

¹¹⁾ On vehicles fitted with the radio navigation system Amundsen+, this function can be accessed via the menu of the radio navigation system, see the operating instructions for the Amundsen+.

¹²⁾ This function is not available in vehicles fitted with the radio navigation system Amundsen+.

Voice mailbox

In the menu **Voice mailbox**, it is possible to set the number of the voice mailbox¹³⁾ and then dial the number.

Bluetooth

In the menu **Bluetooth** you can select the following menu points:

- **User** - the overview of the stored users
- **New user** - Search for new telephones which are in the reception range
- **Visibility** - Switching on the visibility of the telephone unit for other devices
- **Media player**
 - **Active device**
 - **Paired devices**
 - **Search**
- **Phone name** - the possibility to change the name of the telephone unit (pre-set SKODA UHV)

Settings

In the menu **Settings** you can select the following menu points:

- **Phone book**
 - **Update**¹³⁾.
 - **List**
 - **Surname**
 - **First name**
- **Ring tone**

Back

Return in the basic menu of the telephone. ■

¹³⁾ On vehicles fitted with the radio navigation system Amundsen+, this function can be accessed via the menu of the radio navigation system, see the operating instructions for the Amundsen+.

Voice control

Dialogue

On vehicles which are factory-fitted with the navigation system Columbus, it is only possible to operate the voice control via this device, see the operating instructions for Columbus.



The period, in which the telephone system is ready to receive voice commands and carry out the voice commands, is called DIALOGUE. The system gives audible feedback and guides you if necessary through the relevant functions.

Optimum understanding of the voice commands depends on the following factors:

- Speak at a normal volume, without intonation and excessive voice pauses.
- Avoid insufficient articulation.
- Close the doors, windows and sliding roof, in order to reduce or stop disturbing exterior noise.
- It is recommended to speak louder at higher speeds, so that the tone of your voice is louder than the increased surrounding noise.
- During the dialogue avoid additional noise in the vehicle, e.g. simultaneously talking occupants.
- Do not speak, if the system makes an announcement.
- The microphone for voice control is inserted in the moulded headliner and directed to the driver and front passenger. Therefore the driver and the front passenger can operate the equipment.



If a voice command is not detected, the system answers with "Sorry?" and a new entry can be performed. After the 2nd error the system repeats the aid. After the 3rd error the answer "Procedure cancelled" is given and the dialogue is ended.

Switch on voice control (dialogue)



- by briefly pressing the  button on the adapter¹⁴⁾ ⇒ page 124, fig. 125;
- by pressing the  button on the multi-function steering wheel for a longer time ⇒ page 125, fig. 126.

Switching off voice control (dialogue)

If the system is currently playing a message, you will need to end the message currently being played:

- by briefly pressing the  button on the adapter¹⁴⁾;
- by pressing the  button on the multi-function steering wheel for a longer time.

If the system expects a voice command, you can end the dialogue yourself:

- Do some with the **CANCEL** voice command;
- by pressing the  button on the adapter¹⁴⁾;
- by pressing the  button on the multi-function steering wheel for a longer time.

Note

- The dialogue of an incoming call is immediately interrupted.
- The voice control is only possible in vehicles fitted with a multi-function steering wheel with telephone control or a phone holder and adapter. ■

Voice commands

Basic voice commands for operating the telephone control unit

Voice command	Action
HELP	After this command the system repeats all possible commands.
CALL XYZ	With this command you call up the contact from the phone book ⇒ page 128.
PHONE BOOK	After this command, for example the phone book can be repeated, a voice entry for the contact can be updated or deleted etc.
CALL LISTS	Lists of dialed numbers, missed calls etc.
DIAL NUMBER	After this command a phone number can be entered which establishes a connection to the requested party.
REDIAL	After this command the system selects the last selected number.
MUSIC ^{a)}	Play music from the mobile phone or another paired device. ▶

¹⁴⁾ Not valid for vehicles which are fitted with the radio navigation system Columbus.

Voice command	Action
OTHER OPTIONS	After this command the system offers additional context-dependent commands.
SETTINGS	Selection for setting Bluetooth®, dialogue etc.
CANCEL	The dialogue is ended.

a) On vehicles fitted with the radio navigation system Amundsen+, this function can be accessed via the menu of the radio navigation system, see the operating instructions for the Amundsen+.

After giving the command **DIAL NUMBER**, the system requests the entry of a telephone number. The telephone number can be entered as an interconnected spoken row of digits (complete number), in the form of order of digits (separation through a brief voice pause) or through individually spoken digits. After each order of digits (separation through brief voice pause) all of the digits detected up to now are repeated by the system.

The digits **0 - 9**, symbols **+**, *****, **#** are permitted. The system detects no continuous digit combinations such as twenty-three, but only individually spoken digits (two, three). ■

Call name

- Switch on the voice operation ⇒ page 127, "Voice control".
- Give the command **CALL XYZ** after the signal tone.

Example for calling the name from the phone book

Voice command	Announcement
CALL XYZ	"Say home, work, mobile"
e.g. WORK	"XYZ work is dialed."
CALL XYZ WORK	"XYZ work is dialed."

Store voice recording of a contact

If automatic name recognition does not work reliably for some contacts, you will can choose to save your own voice entry for the contact in the **Phone book - Voice Tag - Record** menu point.

You can also store your own voice entry using voice control in the menu **FURTHER OPTIONS**. ■

Music playback via Bluetooth®

The universal telephone preinstallation GSM III makes it possible to play back music via Bluetooth® from the devices such as MP3 player, mobile phone or notebook.

In order to enable the music playback via Bluetooth®, it is necessary to connect the terminal device with the hands-free system in the menu **Phone - Bluetooth - Media player**.

The operation of the music playback from the connected device can be performed via the hands-free system with the voice control ⇒ page 127, "Voice commands" or directly via the connected device.

Note

- The device to be connected must support the Bluetooth® profile A2DP, see Owner's manual of the device to be connected.
- This function is not available in vehicles fitted with the car radio Blues. ■

Universal telephone preinstallation GSM III

Introduction

The universal telephone preinstallation GSM III is a built-in "hands-free system", it provides a voice operated convenience mode via the multifunction steering wheel or the radio navigation system.

The following functions are included in the universal telephone preinstallation GSM III:

- Phone Phonebook ⇒ page 129.
- Convenience mode with the multifunction steering wheel ⇒ page 131 and display in the information display ⇒ page 132.
- Voice control of the telephone, including the language selection of the telephone contacts ⇒ page 134.
- Internet connection ⇒ page 135.
- Music playback from the telephone or other multimedia units ⇒ page 135.
- Display of SMS ⇒ page 132.

All communication between a telephone and the hands-free system of your vehicle can only be established with the help of the following profiles of Bluetooth® technology. ►

rSAP - Remote SIM access profile

After connecting the telephone with the hands-free system via the **rSAP** profile, the telephone deregisters from the GSM network, the control unit ensures the communication with the network via the internal antenna. In the telephone only the interface for Bluetooth® remains active. In this case, you can only separate from the control unit, switch off the Bluetooth® connection or select the number of the emergency call 112 (only valid for some countries).

HFP - Hands Free Profile

After connecting the telephone with the hands-free system via the **HFP** profile, the telephone continues to use its GSM module and internal antenna to communicate with the GSM network.

WARNING

Pay attention primarily to the traffic situation! As the driver you are fully responsible for road safety. Use the telephone system only to such an extent, so that you are in full control of your vehicle at any time.

Note

- The volume can be changed individually during the call at any time with the button for setting the radio or radio navigation system or with the buttons on the multifunction steering wheel.
- Please refer to the following guidelines ⇒ page 122, "Mobile phones and two-way radio systems".
- Should you have any questions, please contact an authorised Škoda Service Partner. ■

Phone Phonebook

A phone phonebook is part of the mobile phone preinstallation with voice control. In the phone phonebook there are 2 000 free memory locations available. Each contact can contain up to 5 numbers. This phone phonebook can be used in line with the mobile telephone.

On vehicles fitted with the radio navigation system Columbus, a maximum of 1000 telephone contacts are shown in the display of this appliance.

After the first connection of the telephone, the system begins to load the phone book from the phone and the SIM card into the memory of the control unit.

If the telephone book of the mobile phone contains more than 2 000 entries, the system announces **Phone book not fully loaded**.

Each time the telephone has established a new connection with the hands-free system, an update of the relevant phone book is performed. The updating can take a few minutes. During this time the phone book, which was stored after the last update was completed, is available. Newly stored telephone numbers are only shown after the updating has ended.

If a telephone event (e.g. incoming or outgoing call, dialogue of the voice control) occurs during the updating procedure, the updating is interrupted. After the telephone event has ended, the updating starts anew. ■

Connection of the telephone with the hands-free system

In order to connect a mobile phone with the hands-free system, it is necessary to connect the telephone to the hands-free system. Detailed information on this is provided in the operating instructions of your mobile phone. The following steps must be carried out for the connection.

Connecting the telephone with the hands-free system via the HFP profile

- Activate the Bluetooth® in your telephone and the visibility of the mobile phone.
- Switch on the ignition.
- Select the menu **Phone - Phone search** in the information display and wait until the control unit has ended the search.
- Select your mobile phone in the menu of the units found.
- Within 30 seconds enter the 16 digit PIN of your control unit as indicated in the information display and confirm it according to the instructions on the display of your telephone.
- To store a new user or to download the telephone book and the identification data of the SIM card into the control unit, follow the instructions in the information display and on the mobile phone.

Connecting the telephone with the hands-free system via the rSAP profile

- Activate the Bluetooth® in your telephone and the visibility of the mobile phone. For certain mobile phones it is necessary to switch on first the **rSAP** function.
- Switch on the ignition.
- Select the menu **Phone - Phone search** in the information display and wait until the control unit has ended the search. ▶

- Select your mobile phone in the menu of the units found.
- Within 30 seconds enter the 16 digit PIN of your control unit as indicated in the information display and confirm it according to the instructions on the display of your telephone.
- If your SIM card is blocked by a PIN code, enter the PIN of the SIM card of your telephone. The telephone connects to the control unit (during the first connection you can only enter it in the information display and when the vehicle is stationary, since you can only choose whether the PIN should be stored in this situation).
- For the first storage of a new user follow the instructions in the information display.
- To download the telephone book and the identification data of the SIM card into the new control unit, confirm again the command **rSAP** in your mobile phone.

The telephone connects preferentially via the **rSAP** profile.

If the PIN was stored, the telephone is automatically detected and connected with the hands-free system when the ignition is switched on the next time. Check on your mobile phone if it was automatically connected.

Disconnecting the connection

The connection to the hands-free system is disconnected:

- When removing the key from the ignition lock (during a telephone call, the connection is disconnected).
- After disconnecting the connection in the telephone.
- After disconnecting the connection in the information display in the **Bluetooth** - **User** - Select user - **Disconnect** menu.

On vehicles which are fitted out with radio or radio navigation system at the factory, it is possible to terminate the telephone call after removing the key from the ignition lock by pressing the icon on the touch-screen of the radio¹⁵⁾ or the radio navigation system, see operating instructions for radio or radio navigation system.



WARNING

- **Pay attention primarily to the traffic situation! As the driver you are fully responsible for road safety. Use the telephone system only to such an extent, so that you are in full control of your vehicle at any time - risk of accident!**



WARNING (continued)

- **In the event of air transport, the Bluetooth® function of the hands-free system must be switched off by a specialist garage!**



Note

- In the memory of the control unit, up to three users can be stored, whereby the hands-free system can only communicate actively with one user. In the case of mutual connection with a fourth mobile phone, you must erase one user.
- Not valid for all mobile phones which enable a communication via Bluetooth®. You can ask at an authorised Škoda Service Partner if your telephone is compatible with the universal telephone preinstallation GSM III.
- When connecting to the control unit, follow the instructions on your mobile phone.
- The range of the Bluetooth® connection to the hands-free system is intended for the vehicle interior. The range is dependent on local factors, e.g. obstacles between the devices and interferences with other devices. ■

¹⁵⁾ Does not apply for Radios Swing and Blues.

Operation of the telephone on the multifunction steering wheel

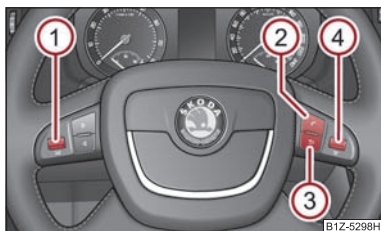

Fig. 127 Multifunction steering wheel: Control buttons for the telephone

The driver can set the basic functions of the telephone by simply operating the buttons located on the steering wheel so that he can concentrate on the traffic situation without being distracted as little as possible by operating the telephone ⇒ fig. 127.

This applies only if your vehicle has been equipped with the telephone preinstallation at the factory.

If the side lights are switched on, the buttons on the multifunction steering wheel are illuminated.

Overview of the different functions in contrast to the multifunction steering wheel without mobile phone operation ⇒ page 120.

Button	Action	Operation
①	press briefly	Activation and deactivation of the voice control (Button PTT - Push to talk) Cancellation of the replayed message
①	↗ turn upwards	Increase volume
①	↘ turn downwards	Decrease volume
②	☎ press briefly	Accept call, end call, entry in the main menu of the telephone, list of the dialed numbers, call the dialed contact
②	☎ press button for a long time	Reject call, list of the last calls, entry in the main menu of the telephone, list of dialed numbers
③	➡ press briefly	Reach one level higher in the menu (according to the current position in the menu)
③	➡ press button for a long time	Leave the phone menu
④	press briefly	Confirm menu selection
④	press button for a long period of time	To the next initial letter in the telephone book
④	△ turn upwards	The last chosen menu selection, name
④	▽ turn downwards	The next menu selection, name
④	△ quickly turn upwards	To the previous initial letter in the telephone book
④	▽ quickly turn downwards	To the next initial letter in the telephone book

The buttons operate the functions for the operating mode of the current telephone. ■

Operate the telephone via the information display

If no telephone is connected with the hands-free system, after you select the **Phone** menu, the **No paired phone found** message will appear and the following menu points:

- **Help** this menu point appears when no paired phone is stored in the memory of the control unit.
- **Connect** this menu point appears when one or more paired phones are stored in the memory of the control unit.
- **Phone search**
- **Media player**
 - **Active device**
 - **Paired devices**
 - **Search**
 - **Visibility**
- **SOS**

If a telephone is coupled with the hands-free system, you can choose the following menu points in the **Phone** menu:

- **Phone book**
- **Dial number**
- **Call register**
- **Voice mailbox**
- **Messages**¹⁶⁾
- **Bluetooth**
- **Settings**
- **Back**

Phone book

In the menu point **Phone book** is the list of the loaded contacts from the telephone memory and the SIM card of the mobile phone.

The following functions are available for each phone contact:

- Display telephone number
- **Voice Tag**
 - **Replay**
 - **Record**

Dial number

In the menu point **Dial number**, you can write any telephone number. Select in sequence the desired digits with the aid of the handwheel and confirm it by pressing the handwheel. You can select the numbers **0 - 9**, the symbols **+**, *****, **#** and the functions **Delete**, **Call**, **Back**.

Call register

In the menu point **Call register**, you can select the following menu points:

- **Missed calls**
- **Received calls**
- **Dialled numbers**
- **Delete lists**

Voice mailbox

In the menu **Voice mailbox**, it is possible to set the number of the voice mailbox and then dial the number. Select in sequence the desired digits with the aid of the handwheel and confirm it by pressing the handwheel. You can select the numbers **0 - 9**, the symbol **+** and the functions **Delete**, **Call**, **Save**, and **Back**.

Messages

In the menu point **Messages** there is a list of received text messages. After calling a message, the following functions appear:

- **Show**
- **Read** - the system reads out the selected message through the vehicle's speakers
- **Send time**
- **Callback**
- **Copy** - copies the incoming message to the SIM card
- **Delete lists**

Bluetooth

In the menu **Bluetooth** you can select the following menu points:

- **User** - the overview of the stored users
 - **Connect**

¹⁶⁾ Only when connecting the telephone with the hands-free system via the rSAP profile.



- **Disconnect**
- **Rename**
- **Delete**
- **New user** - Search for users who are in the reception range
- **Visibility** - Switching on the visibility of the hands-free system for other devices
- **Media player**
 - **Active device**
 - **Paired devices** .
 - **Connect**
 - **Rename**
 - **Delete**
 - **Authorisation**
 - **Search** - search for available media players
 - **Visibility** - Switching on the visibility of the media player hands-free system in the environment
- **Extras**
 - **Modem** - overview of the active and paired devices for the connection to the internet
 - **Active device**
 - **Paired devices** .
 - **Phone name** - the possibility to change the name of the hands-free system (pre-set SKODA UHV)

Settings

In the menu **Settings** you can select the following menu points:

- **Phone book**
 - **Update** - scan the telephone book
 - **Select memory**
 - **SIM & phone**
 - **SIM card**
 - **Mobile phone** - Initial setting which allows contacts on the SIM card to be scanned, it is necessary to switch to the menu point **SIM & phone**
 - **List**
 - **Surname**
 - **First name**

- **Own number** - optionally display your own telephone number on the display of the device of the person you are calling (this function is network-dependent)
 - **Network depnd.** .
 - **Yes**
 - **No**
- **Signal settings**
 - **Ring tone**
 - **Volume**
 - **Turn vol. up**
 - **Turn vol. down**
- **Phone settings**
 - **Select operator**
 - **Automatic**
 - **Manual**
 - **Network mode**
 - **GSM**
 - **Automatic**
 - **SIM mode** - valid for telephones with the rSAP profile, in which the operation of two SIM cards simultaneously is supported - you can choose which SIM card you want to associate with the hands-free system
 - **Change**
 - **Phone Mode** - Toggle between rSAP and HFP mode
 - **Premium** - rSAP mode
 - **Handsfree** - HFP mode
 - **Off time** - Setting in five-minute steps
 - **Data** - Settings for the Internet access point - ask network operator for details
 - **Switch off ph.** - switches off the phone unit (phone remains coupled)

Back

Return in the main menu of the information display. ■

Voice control

Dialogue

On vehicles which are factory-fitted with the navigation system Columbus, it is only possible to operate the voice control via this device, see the operating instructions for Columbus.

The period, in which the telephone system is ready to receive voice commands and carry out the voice commands, is called DIALOGUE. The system gives audible feedback and guides you if necessary through the relevant functions.

Optimum understanding of the voice commands depends on the following factors:

- Speak at a normal volume, without intonation and excessive voice pauses.
- Avoid insufficient articulation.
- Close the doors, windows and sliding roof, in order to reduce or stop disturbing exterior noise.
- It is recommended to speak louder at higher speeds, so that the tone of your voice is louder than the increased surrounding noise.
- During the dialogue avoid additional noise in the vehicle, e.g. simultaneously talking occupants.
- Do not speak, if the system makes an announcement.
- The microphone for voice control is inserted in the moulded headliner and directed to the driver and front passenger. Therefore the driver and the front passenger can operate the equipment.

Switch on voice control (dialogue)

You can start the dialogue at any time by pressing the  button on the multi-function steering wheel ⇒ page 131.

If the system does not recognise your command, it repeats the first part of the aid and thus a new entry is possible. After the 2nd error the system repeats the second part of the aid. After the 3rd error the answer "Procedure cancelled" is given and the dialogue is ended.

Switching off voice control (dialogue)

If the system is currently playing a message, you will need to end the message currently being played by pressing the  button on the multi-function steering wheel.

If the system expects a voice command, you can end the dialogue yourself:

- Do some with the **CANCEL** voice command;
- by pressing the  button on the multi-function steering wheel.



Note

The dialogue of an incoming call is immediately interrupted. ■

Voice commands

Basic voice commands for operating the telephone control unit

Voice command	Action
HELP	After this command the system repeats all possible commands.
CALL NAME	After this command a name can be entered which establishes a connection to the requested partner.
DIAL NUMBER	After this command a phone number can be entered which establishes a connection to the requested party.
REDIAL	The last selected telephone number is selected.
READ LIST OF NAMES	The system reads the contacts in the telephone book.
READ NEWS	The system reads the messages which were received while the telephone was connected with the hands-free system.
SHORT DIALOGUE	Help is clearly reduced (good operating knowledge provided).
LONG DIALOGUE	Help is not reduced (suitable for beginners).
CANCEL	The dialogue is ended.

Store voice recording of a contact

If automatic name recognition does not work reliably for some contacts, you will can choose to save your own voice entry for the contact in the menu point **Phone book - Voice Tag - Record**.

You can also store your own voice entry using voice control in the menu **FURTHER OPTIONS**. ■

Internet connection

An Internet connection can be established via a PC or PDA.

The control unit on the hands-free system supports the GPRS, EDGE and UMTS/3G technologies.

An Internet is only possible via a telephone which is connected via the rSAP profile.

The procedure for connecting to the Internet can vary depending on the type and version of the operating system as well as the type of the device to be connected. Successfully connecting to the internet requires appropriate knowledge of the operating system for connecting the device .

Process of connection

- Connect the mobile phone with the hands-free system.
- Set the access point (depending on the operator, usually the "Internet") in the menu **Phone - Settings - Data** .
- Switch on the visibility of the hands-free system for the other devices in the menu **Phone - Bluetooth - Visibility**.
- Have the device to be connected search for available Bluetooth® devices.
- From the list of found devices, choose the hands-free system ("SKODA_BT" by default).
- On the device to be connected, enter the password and follow any instructions given on this device or in the information display.
- Enter the required Internet address in the browser. The operating system requests the entry of the telephone number for the internet access (depending on the operator, usually **99#"). ■

Music playback via Bluetooth®

The universal telephone preinstallation GSM III makes it possible to play back music via Bluetooth® from the devices such as MP3 player, mobile phone or notebook.

In order to enable the music playback via Bluetooth®, it is necessary to first connect the device to be connected with the hands-free system in the menu **Phone - Bluetooth - Media player**.

The music playback process is performed on the connected device.

Note

- The device to be connected must support the Bluetooth® profile A2DP, see Owner's manual of the device to be coupled.
- This function is not available in vehicles fitted with the car radio Blues. ■

Multimedia

AUX-IN and MDI inputs

The input AUX-IN is located below the armrest of the front seats and is marked with **AUX**.

The input MDI is located in the storage compartment on the front passenger side.

The inputs AUX-IN and MDI are used to connect external audio sources (e.g. iPod or MP3 player) and play back music from these devices via your factory-fitted radio or radio navigation system.

The description of the operation can be found in the relevant Owner's Manual of your radio or your radio navigation system.

Note

- The loudspeakers in the vehicle are designed to match the power output of the radio and radio navigation system of 4x 20°W.
- For the equipment sound system, the loudspeakers are matched to a power output of the amplifier of 4x40°W + 6x20 W. ■

CD changer

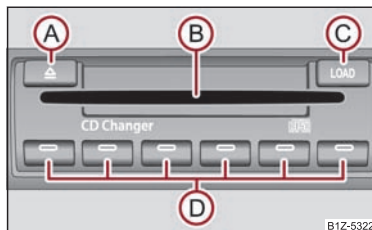

Fig. 128 The CD changer

The CD changer for the radio and radio navigation system is located in the left side compartment of the luggage compartment.

Insert a CD

- Touch the button **(C)** => page 135, fig. 128 and guide the CD (compact disc) into the CD-case **(B)**. The CD is automatically loaded onto the lowest free position in the CD changer. The LED in the corresponding button **(D)** stops flashing.

Fill CD changer with CDs

- Hold the button **(C)** pressed for longer than 2 seconds and guide the CDs one after the other (maximum 6 CDs) into the CD case **(B)**. The LEDs in the buttons **(D)** are no longer flashing.

Inserting a CD to one definite position

- Briefly touch the button **(C)**. The LEDs in the buttons **(D)** light up at the memory spaces, which are already assigned and flash in the case of free memory spaces.
- Touch the desired button **(D)** and guide the CD into the CD-case **(B)**.

Ejecting a CD

- Briefly touch the button **(A)**, in order to eject a CD. For assigned memory spaces, now the LEDs light up in the buttons **(D)**.
- Touch the corresponding button **(D)**. The CD is ejected.

Ejecting all CDs

- Hold the button **(A)** pressed for more than 2 seconds, in order to eject the CDs. All CDs in the CD-changer are ejected consecutively.



Note

- Always guide the CD into the CD-case **(B)** with the printed side pointing upwards.
- Never push the CD with force into the CD-case as the insertion is performed automatically.
- After loading a CD into the CD-changer, you must wait until the LED of the corresponding button **(D)** lights up. Then the CD-case **(B)** is free to load the next CD.
- If you have selected a position, on which a CD is already located, this CD will be ejected. Take out the ejected CD and load the desired CD. ■

Safety

Passive Safety

Basic information

Driving the safe way

Passive safety measures reduce the risk of injury in accident situations.

In this section you will find important information, tips and notes on the subject of passive safety in your vehicle. We have combined everything here which you should be familiar with, for example, regarding seat belts, airbags, child seats and safety of children. It is therefore important, in particular, to comply with the notes and warnings in this section for your own interest and in the interest of those travelling with you.

WARNING

- This chapter contains important information on how to use the vehicle for the driver and his occupants. You will find further information on safety, which concerns you and those travelling with you, in the following chapters of this Owner's Manual.
- The complete on-board literature should always be in the vehicle. This applies in particular, if you rent out or sell the vehicle. ■

Safety equipment

The safety equipment is part of the occupant protection and it can reduce the risk of injuries in accident situations.

"Do not put at risk" your safety and the safety of those travelling with you. In the event of an accident, the safety equipment can reduce the risk of injuries. The following list contains part of the safety equipment in your vehicle:

- three-point seat belts for all the seats;
- belt force limiter for front and outer rear seats;
- belt tensioners for front seats;
- seat belt height adjusters for front seats;

- front airbags for the driver and the front passenger;
- side airbags;
- head airbags;
- anchoring points for child seat using the "ISOFIX" system;
- anchoring points for child seat using the "Top Tether" system;
- head restraints adjustable for height;
- adjustable steering column.

The specified safety equipment works together, in order to optimally protect you and those travelling with you in accident situations. The safety equipment does not protect you or the people travelling with you, if you or your occupants adopt an incorrect seated position or the equipment is not correctly adjusted or used.

For this reason you will be provided with information on why these equipment components are very important, how it protects you and the occupants, what should be observed when using the equipment and how you and the people travelling with you can make full use of the existing safety equipment. This Owner's Manual contains important warning notes, which you and those travelling with you should pay attention to in order to reduce a risk of injury.

Safety concerns everybody! ■

Before setting off

The driver is always fully responsible for his occupants and for the operating safety of the vehicle.

For your own safety and the safety of the people travelling with you, please pay attention to the following points before setting off.

- Ensure that the lighting and the turn signal system are functioning properly.
- Inspect the tyre inflation pressure.
- Ensure that all the windows offer a good visibility to the outside.
- Safely attach the items of luggage ⇒ page 71, "Loading the luggage compartment".
- Ensure that no objects can obstruct the pedal.
- Adjust the mirror, the front seat and the head restraint to match your body size. ►

- Point out to your occupants that the head restraints must be adjusted to match their body size.
- Protect the children in suitable child seats with correctly fastened seat belts ⇒ page 153, "Transporting children safely".
- Adopt the correct seated position ⇒ page 138, "Correct seated position". Also inform your occupants to adopt the correct seated position.
- Fasten the seat belt correctly. Also inform your occupants to properly fasten the seat belts ⇒ page 143, "How are seat belts correctly fastened?". ■

What influences the driving safety?

The driving safety is primarily determined by the style of driving and the personal behaviour of all the occupants.

The driver is fully responsible for himself and his occupants. If your driving safety is effected, you place yourself and the oncoming traffic at risk. Please refer to the following guidelines.

- Do not get distracted from concentrating on the traffic situation, e.g. by your occupants or mobile phone calls.
- Never drive when your driving ability is impaired, e.g. through medication, alcohol, drugs.
- Keep to the traffic regulations and the permissible speed limit.
- Adjust the driving speed at all times to the road condition as well as to the traffic and weather conditions.
- Take regular breaks on long journeys - at the latest every two hours. ■

Correct seated position

Correct seated position for the driver

Correct seated position for the driver is important for safe and relaxed driving.

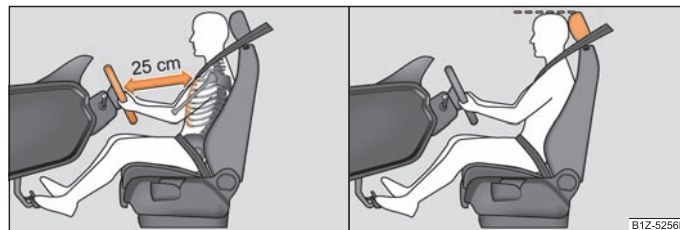

Fig. 129 The correct distance of the driver from the steering wheel/The correct head restraint adjustment for the driver

For your own safety and to reduce the risk of injury in the event of an accident, we recommend the following setting.

- Adjust the steering wheel so that the distance between the steering wheel and your chest is at least 25 cm ⇒ fig. 129 - left.
- Position the driver seat in the forward/back direction so that you are able to fully press the pedals with your legs at a slight angle.
- Adjust the seat backrest so that you are able to reach the highest point of the steering wheel with your arms at a slight angle.
- Adjust the head restraint so that the top edge of the head restraint is at the same level as the upper part of your head ⇒ fig. 129 - right.
- Fasten the seat belt correctly ⇒ page 143, "How are seat belts correctly fastened?".

Manual driver seat adjustment ⇒ page 11, "Adjusting the front seats".

Electrical driver seat adjustment ⇒ page 65, "Adjusting front seats electrically".



WARNING

- The front seats and the head restraints must always be adjusted to match the body size of the seat occupant as well as the seat belts must always be

⚠ WARNING (continued)

correctly fastened in order to provide an optimal protection for you and your occupants.

- The driver must maintain a distance of at least 25 cm to the steering wheel ⇒ [page 138, fig. 129](#) left. Not maintaining this minimum distance will mean that the airbag system will not be able to properly protect you - hazard!
- When driving, hold the steering wheel with both hands firmly on the outer edge in the 9 o'clock and 3 o'clock position. Never hold the steering wheel firmly in the 12 o'clock position or in another way (e.g. in the middle of the steering wheel or at the inner steering wheel edge). In such cases, injuries to the arms, the hands and the head can occur when the driver airbag is deployed.
- The seat backrests must not be angled too far back when driving otherwise this will affect proper operation of the seat belts and of the airbag system - risk of injury!
- Ensure that there are no objects in the footwell as any objects may get behind the pedals during a driving or braking manoeuvre. You would then no longer be able to operate the clutch, to brake or accelerate. ■

Correct seated position for the front passenger

The front passenger must maintain a distance of at least 25 cm from the dash panel so that the airbag offers him the greatest possible safety it is deployed.

For the safety of the front passenger and to reduce the risk of injury in the event of an accident, we recommend the following setting:

- Adjust the front passenger seat as far as possible to the rear.
- Adjust the head restraint so that the top edge of the head restraint is at the same level as the upper part of your head ⇒ [page 138, fig. 129](#) - right.
- Fasten the seat belt correctly ⇒ [page 143](#), "How are seat belts correctly fastened?".

In exceptional cases the front passenger airbag can be deactivated ⇒ [page 151](#), "Deactivating an airbag".

Manual front passenger adjustment ⇒ [page 11](#), "Adjusting the front seats".

Electrical front passenger seat adjustment ⇒ [page 65](#), "Adjusting front seats electrically".

⚠ WARNING

- The front seats and the head restraints must always be adjusted to match the body size of the seat occupant as well as the seat belts must always be correctly fastened in order to provide an optimal protection for you and your occupants.
- The front passenger must maintain a distance of at least 25 cm to the dash panel. Not maintaining this minimum distance will mean that the airbag system will not be able to properly protect you - hazard!
- Always keep your feet in the footwell when the car is being driven - never place your feet on the instrument panel, out of the window or on the surfaces of the seats. You will be exposed to increased risk of injury if it becomes necessary to apply the brake or in the event of an accident. If an airbag is deployed, you may suffer fatal injuries when adopting an incorrect seated position!
- The seat backrests must not be angled too far back when driving otherwise this will affect proper operation of the seat belts and of the airbag system - risk of injury! ■

Correct seated position for the occupants on the rear seats

Occupants on the rear seats must sit upright, keep the feet in the footwell and must have their seat belts correctly fastened.

To reduce the risk of injury in the event of a sudden braking manoeuvre or an accident, the occupants on the rear seats must observe the following:

- Adjust the head restraints so that the top edge of the head restraints is at the same level as the upper part of your head ⇒ [page 138, fig. 129](#) - on the right.
- Fasten the seat belt correctly ⇒ [page 143](#), "How are seat belts correctly fastened?".
- If you are transporting ⇒ [page 153](#), "Transporting children safely" children in the vehicle, please use a suitable child restraint system.

⚠ WARNING

- The head restraints must always be adjusted to match the body size, in order to offer an optimal protection for you and your occupants.
- Always keep your feet in the footwell when the car is being driven - never put your feet out of the window or on the surfaces of the seats. You will be exposed to increased risk of injury if it becomes necessary to apply the brake or in the event of an accident. If the head airbag is deployed and when adopting an

⚠ WARNING (continued)

incorrect seated position, you are exposing yourself to an increased risk of injury and in the event of an accident you may suffer fatal injuries!

- If the occupants on the rear seats are not sitting upright, the risk of injury is increased due to incorrect routing of the seat belt. ■

Examples of an incorrect seated position

An incorrect seated position can lead to severe injuries or death for the occupants.

Seat belts offer their optimum protection only if the webbing of the seat belts is properly routed. Incorrect seated positions considerably reduce the protective functions of the seat belts and therefore increase the risk of injury due to an incorrect routing of the seat belt. The driver is fully responsible for himself and the occupants, in particular for the children. Do not permit an occupant to adopt an incorrect seated position when the car is moving.

The following list contains the examples of seated positions which are dangerous for the occupants. This list is not complete, however we would like you to get interested in this subject.

Therefore, while the car is moving never:

- stand up in the vehicle;
- stand up on the seats;
- kneel on the seats;
- tilt the seat backrest fully to the back;
- lean against the dash panel;
- lie on the rear seat bench;
- only sit on the front area of the seat;
- sit to the side;
- lean out of the window;
- put the feet out of the window;
- put the feet on the dash panel;
- put the feet on the seat upholstery;
- transport somebody in the footwell;
- have the seat belt not fastened when driving;
- occupy the luggage compartment.

⚠ WARNING

- If the occupant adopts an incorrect seated position, he is exposed to life-threatening injuries, in case he is hit by a deployed airbag.
- Before setting off, please adopt the correct seated position and do not change this seated position while the car is moving. Also advise your occupants to adopt the correct seated position and not to change this seated position while the car is moving. ■

Seat belts

Why seat belts?



Fig. 130 Driver wearing seat belt

It is a proven fact that seat belts offer good protection in accidents \Rightarrow fig. 130. Thus wearing a seat belt is a legal requirement in most countries.

Seat belts which have been correctly fastened and adjusted hold the occupants of the car in the correct seated position \Rightarrow fig. 130. The seat belts reduce the kinetic energy (energy of motion) to a considerable extent. They also prevent uncontrolled movements which, in turn, may well result in severe injuries.

The occupants of a vehicle who have fastened and correctly adjusted their seat belt, profit to a major extent from the fact that the kinetic energy is optimally absorbed by the belts. The structure of the front end of the vehicle and other passive safety measures, such as the airbag system, also contribute to reducing the kinetic energy. The energy produced is thus absorbed and there is less risk of injury.

Accident statistics prove that seat belts which are fastened and properly adjusted reduce the risk of an injury and enhance the chance of survival in a major accident \Rightarrow page 141.

It is important that you pay attention to safety measures, particularly when transporting children in the vehicle \Rightarrow page 153, "Transporting children safely".

WARNING

- Fasten your seat belt each time before setting off - also when driving in town! This also applies to the people seated at the rear - risk of injury!
- Expectant women must also always wear a seat belt. This is the only way of ensuring optimal protection for the unborn child \Rightarrow page 143, "How are seat belts correctly fastened?".

WARNING (continued)

- It is important for the belt webbing to be properly routed if the seat belts are to offer the maximum protection. You can see a description of how safety belts should be fitted properly on the next pages.

Note

Please comply with any differing legal requirements when using the seat belts. ■

The physical principle of a frontal collision

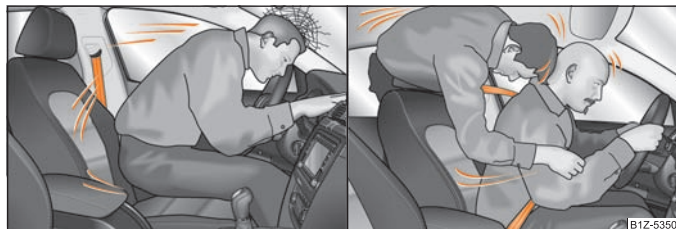

Fig. 131 The driver is catapulted forward if not wearing a belt/The rear seat occupant is catapulted forward if not wearing a belt

The physical principle of a frontal accident can be explained quite simply:

Motion energy, so-called kinetic energy, is produced as soon as the vehicle is moving, both for the vehicle and its occupants. The magnitude of this kinetic energy depends essentially on the speed at which the vehicle is travelling and on the weight of the vehicle including the occupants. The greater the speed and weight increase, the greater the amount of energy which has to be absorbed in the event of an accident.

The speed of the vehicle is, nevertheless, the most important factor. Doubling the speed of the vehicle from 25 km/h up to 50 km/hour increases the kinetic energy four times. ▶

The common opinion that it is possible to support your body in a minor accident with your hands, is incorrect. Even in a collision at only a low speed, the forces acting on the body are such that it is no longer possible to support your body.

Even if you only drive at a speed within the range from 30 km/hour to 50 km/hour, the forces which are produced on your body in the event of an accident can easily exceed 10 000 N (Newton). This equals a weight of one tonne (1 000 kg).

In the event of a frontal collision, occupants of the vehicle not wearing a seat belt, are thrown forward and strike in an uncontrolled way parts of the interior of the vehicle, such as steering wheel, dash panel, windscreen, ⇒ [page 141, fig. 131](#) - left. The occupants of a vehicle who have not fastened their seat belts may even be thrown out of the vehicle. This can result in fatal injuries.

It is also important that rear seat occupants fasten their seat belts as they will otherwise be thrown through the vehicle in an uncontrolled manner in the event of an accident. A rear seat passenger who has not fastened the seat belt is a danger not only to himself but also for those seated at the front ⇒ [page 141, fig. 131](#) - right. ■

Important safety information regarding the use of seat belts

The correct use of the seat belts considerably reduces the risk of injury!



WARNING

- The belt webbing must not be jammed in-between at any point or twisted, or chafe against any sharp edges.
- It is important that the belt webbing is properly routed if the seat belts are to offer their maximum protection ⇒ [page 143, "How are seat belts correctly fastened?"](#).
- No two persons (also not children) should ever use a single seat belt together.
- The maximum protection which seat belts can offer is only achieved if you are correctly seated ⇒ [page 138, "Correct seated position"](#).
- The belt webbing must not run across solid or fragile objects (e.g. spectacles, ball-point pens, keys etc.) as this may be a cause of injuries.
- Many layers of clothing and loose clothing (e. g. a winter coat over a jacket) do not allow you to be correctly seated and impairs proper operation of the seat belts.



WARNING (continued)

- It is prohibited to use clamps or other objects to adjust seat belts (e. g. for shortening the belts for smaller persons).
- The lock tongue should only be inserted into the lock which is the correct one for your seat. Wrong use of the safety belt will reduce its capacity to protect and the risk of injury increases.
- The seat backrests of the front seats must not be tilted too far to the rear otherwise the seatbelts can lose their effectiveness.
- The three-point seat belt for the rear middle seat can only fulfil its function reliably when the backrests are correctly locked into position ⇒ [page 68](#).
- The belt webbing must always be kept clean. Soiled belt webbing may impair proper operation of the inertia reel ⇒ [page 182, "Seat belts"](#).
- The slot of the belt tongue must not be blocked by paper or similar objects otherwise the belt tongue will not lock in place properly.
- Inspect the seat belts regularly to ensure they are in good condition. If you find seat belts which have damage to the belt, the seat belt connections, to the inertia reel or to the lock, the relevant seat belt must be replaced by a specialist garage.
- The seat belts must not be removed or changed in any way. Do not make an attempt to repair the seat belts yourself.
- Damaged seat belts which have been subjected to stress in an accident and were therefore stretched, must be replaced - this is best done by a specialist garage. The anchorage points of the belts must also be inspected. The anchorage points for the belts should also be checked.
- In certain countries it is possible to use seat belts which differ in terms of their operation from the seat belts which are described on the pages which follow. ■

How are seat belts correctly fastened?

Fastening three-point seat belts

Fasten your seat belt before starting!



Fig. 132 Routing of belt webbing over the shoulders and the lap belt/Routing of belt webbing for an expectant mother

- Correctly adjust the front seat and the head restraint before fastening your seat belt ⇒ page 138, "Correct seated position".
- Slowly pull the belt webbing at the tongue of the lock over your chest and pelvis ⇒ ⚠.
- Insert the tongue of the lock into the seat belt buckle belonging to the seat until it is heard to lock in place.
- Pull on the seat belt to check that it has also reliably engaged in the lock.

Each three-point seat belt is equipped with an inertia reel. This inertia reel offers you complete freedom of movement if the belt is unreeled slowly. If the brakes are applied suddenly, the inertia reel will block. The belts also block when the car accelerates, when driving downhill and when cornering.

Expectant mothers must also wear the seat belt ⇒ ⚠.

⚠ WARNING

- The shoulder part of the seat belt must never run across your neck but must run approximately over the middle of the shoulder and fit snugly against the chest. The lap part of the belt must run across the hip and must never be routed across the stomach. It must always fit snugly ⇒ fig. 132 - left. Adjust the belt webbing as required.

⚠ WARNING (continued)

- The lap part of the belt should be positioned as low as possible at the pelvis of an expectant mother in order to avoid exerting any pressure on the lower abdomen ⇒ fig. 132 - right.
- Always ensure that the webbing of the seat belts is properly routed. Seat belts which are not correctly adjusted can themselves cause injuries even in minor accidents.
- A seat belt which is hanging too loose can result in injuries as your body is moved forward by the kinetic energy produced in an accident and is then suddenly held firm by the belt.
- Only insert the lock tongue into the lock which is the correct one for your seat. This will affect the protection which the belt offers and increase the risk of an injury. ■

Seat belt height adjuster on the front seats



Fig. 133 Front seat: Seat belt height adjuster

The seat belt height adjuster makes it possible for you to adapt the routing of the front three-point seat belt in the area of the shoulder to match your body size.

- Press and move the height adjuster in the desired direction up or down ⇒ fig. 133.
- Then pull firmly on the belt to ensure that the seat belt height adjuster has correctly locked in place. ▶

WARNING

Adjust the height of the belt in such a way that the shoulder part of the belt is positioned approximately across the middle of your shoulder - on no account across your neck.

Note

It is also possible to adapt the routing of the belt webbing at the front seats by adjusting the height of the seat. ■

Taking seat belts off

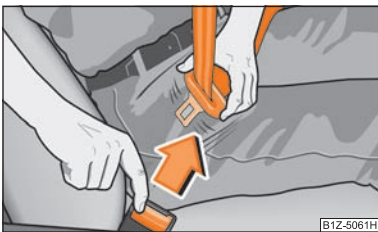

Fig. 134 Releasing lock tongue from belt lock

- Press the red button in the belt lock ⇒ fig. 134. The spring force causes the tongue of the lock to jump out.
- Guide the seat belt back with your hand to enable the inertia reel to wind up the belt webbing more easily.

A plastic knob in the belt webbing holds the belt tongue in a position which is easy to get hold of. ■

Belt tensioners

Safety for the driver and front passenger **wearing their seat belts** is enhanced by the belt tensioners fitted to the inertia reels of the front three-point seat belts, in addition to the protection afforded by the airbag system.

The three-point seat belts are automatically tensioned in the event of a frontal collision of a certain severity. The belt tensioners can also be deployed if the seat belts are not fastened.

The fastened three-point seat belts are automatically tensioned in the event of a frontal or side collision of a certain severity.

Belt tensioners are not activated in the event of minor frontal collisions, side and rear-end collisions, in the case of a rollover and also not in accidents in which no major forces are produced from the front.

WARNING

- Any work on the system including removal and installation of system components because of other repair work, must only be carried out by a specialist garage.
- The protective function of the system is only adequate for a single accident. If the belt tensioners have been deployed, it is then necessary to replace the entire system.
- The seller must pass on this Owner's manual to the buyer upon purchase of the vehicle.

Note

- Smoke is generated when the belt tensioners are deployed. This is not an indication of a fire in the vehicle.
- It is essential to pay attention to relevant safety regulations if the vehicle or individual parts of the system are scrapped. Specialist garages are familiar with these regulations and will be able to provide you with detailed information in this respect.
- When disposing of vehicle or parts of the system, it is important to comply with the national legal requirements. ■

Airbag system

Description of the airbag system

General information on the airbag system

The front airbag system is complementary to the three-point seat belts and offers additional protection for the head and chest area of the driver and passenger in the event of a frontal collision.

In the event of a side collision, the side airbags reduce the risk of injury to the occupants to the part of their body facing the side of the accident.

The airbag system is only functional after the ignition has been switched on.

The operational readiness of the airbag system is monitored electronically. The airbag warning light comes on for a few seconds each time the ignition is switched on.

The airbag system (according to vehicle equipment) consists of:

- an electronic control unit;
- the front airbags for the driver and front passenger ⇒ page 146;
- the side airbags ⇒ page 148;
- head airbags ⇒ page 150;
- an airbag indicator light in the instrument cluster ⇒ page 29;
- a front passenger airbag switch ⇒ page 152;
- an indicator light for a switched off front seat passenger airbag in the middle of the dash panel ⇒ page 152.

A fault in the airbag system exists if:

- the airbag indicator light does not light up when the ignition is switched on;
- the warning light does not go out after about 4 seconds after the ignition is switched on;
- the airbag indicator light goes out and comes on again after the ignition is switched on;
- the airbag indicator light comes on or flickers when driving;
- the airbag indicator light showing a switched-off front passenger airbag in the middle of the dash panel flashes.



WARNING

- To enable the occupants of a vehicle to be protected with the greatest possible effect when the airbag is deployed, the front seats must be ⇒ page 138, "Correct seated position" correctly adjusted to match the body size of the occupant.
- If you do not fasten the seat belts when driving, lean too far forward or adopt an incorrect seated position, you are exposing yourself to increased risk of injury in the event of an accident.
- Have the airbag system checked immediately by a specialist garage if a fault exists. Otherwise, there is a risk of the airbag not being activated in the event of an accident.
- No modifications of any kind may be made to parts of the airbag system.
- It is prohibited to manipulate individual parts of the airbag system as this might result in the airbag being deployed.
- The protective function of the airbag system is sufficient for only one accident. The airbag system must then be replaced if the airbag has been deployed.
- The airbag system needs no maintenance during its working life.
- If you sell your car, please hand over the complete vehicle documentation to the new owner. Please note that the documents relating to the possibility of deactivating the front passenger airbag are also part of the vehicle documents!
- If the vehicle or individual parts of the airbag system are scrapped, it is essential to observe the relevant safety precautions. The authorised Skoda Service Partners are familiar with these regulations.
- When disposing of vehicle or parts of the airbag system, it is important to comply with the national legal requirements. ■

When are the airbags deployed?

The airbag system is designed in such a way that the driver and front passenger airbag are deployed in the event of a **violent frontal collision**.

In the case of a **violent side crash**, the side airbag in the front seat and the head airbag on the side on which the collision occurs are deployed.

It is also possible under certain special accident situations that the front as well as the side airbags and head airbags are deployed simultaneously. ►

The airbags **are not deployed** in the case of **minor** frontal and side collisions, rear-end collisions, tilting of the vehicle and vehicle rollover.

Deployment factors

It is not possible to state globally which deployment conditions apply to the airbag system in every situation as the circumstances which exist in the case of accidents vary greatly. An important role in this case, for example, is played by factors such as the type of object against which the vehicle impacts (hard, soft), the angle of impact, the vehicle speed etc.

A decisive factor for the deployment of the airbags is the deceleration which occurs during a collision. The control unit analyses the nature of the collision and activates the relevant restraint system. If the vehicle deceleration which occurs and is measured during the collision remains below the prescribed reference values specified in the control unit, the airbags are not deployed although the vehicle may well suffer severe damage to the bodywork as a consequence of the accident.

The airbags are not deployed if:

- ignition is switched off;
- a minor frontal collision;
- a minor side collision;
- a rear-end collision;
- Rollover of the vehicle.



Note

- A grey white or red, non harmful gas is released when airbag is inflated. This is perfectly normal and is not an indication of a fire in the vehicle.
- In the event of an accident in which the airbags are deployed:
 - the interior lighting comes on (if the switch for the interior light is in the door contact position),
 - the hazard warning light is switched on;
 - all the doors are unlocked;
 - the fuel supply to the engine is interrupted. ■

Front airbags

Description of the front airbags

The airbag system is not a substitute for the seat belt!

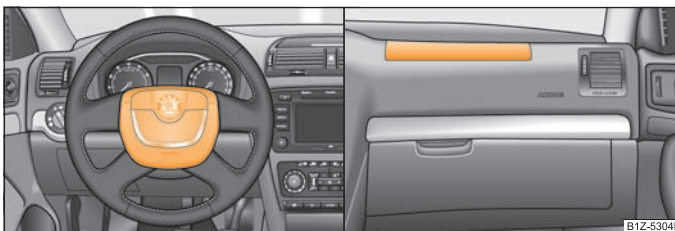

Fig. 135 Driver airbag in the steering wheel/front passenger airbag in the dash panel

The front airbag for the driver is housed in the steering wheel ⇒ fig. 135 - left. The front airbag for the front passenger is housed in the dash panel above the storage compartment ⇒ fig. 135 - right. The installation positions are each marked with the "AIRBAG" logo.

The front airbag system, in combination with three-point safety belts, offers additional protection for the head and chest area of the driver and front passenger in the event of a frontal collision of major severity ⇒ page 147.

The airbag is not a substitute for the seat belt, but is part of the complete passive vehicle safety concept. **Please note that an airbag can only offer you optimal protection in combination with a seat belt which is fastened.**

Apart from their normal protective function, a further task of the **seat belts** is to also hold the driver and front passenger in a correct seated position in the event of a frontal collision so as to enable the front airbags to offer the maximum protection.

You should therefore always fasten the seat belts, not only because this is required by law, but also for safety reasons and for your own protection ⇒ page 141, "Why seat belts?"



Note

The dash panel must be replaced after the front passenger airbag has been deployed. ■

Function of the front airbags

Risk of injury to the head and chest area is reduced by fully inflated airbags.



Fig. 136 Inflated airbags

The airbag system is designed in such a way that the airbags for the driver and front passenger are deployed in the event of a violent frontal collision.

In certain accident situations, the front, side and head airbag are simultaneously deployed.

If the airbags are deployed, the airbags are filled with a propellant gas and inflated in front of the driver and front passenger ⇒ fig. 136. The airbags inflate in fractions of a second and at a high speed in order to be able to offer that additional protection in the event of an accident. The forward movement of the driver and of the front passenger is cushioned when they make contact with the fully inflated airbag and the risk of injury to head and chest is thus reduced.

The specially developed airbag allows the gas to flow out of the inflated airbag in a controlled manner (depending on the load of the particular car occupant) in order to cushion head and chest areas. The airbag then deflates subsequently to such an extent, after an accident, to again provide a clear view forward.

A grey white, non harmful gas is released when airbag is inflated. This is perfectly normal and is not an indication of a fire in the vehicle.

The airbag develops enormous forces when triggered, which can lead to injuries if the sitting position or seated position is not correct ⇒ ⚠ in "Important safety information regarding the front airbag system". ■

Important safety information regarding the front airbag system

Correct use of the airbag system considerably reduces the risk of injury!

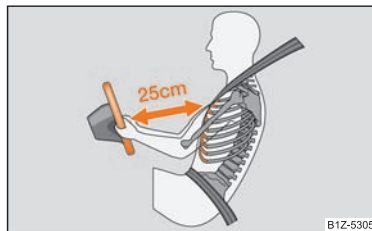

Fig. 137 Safe distance to steering wheel

⚠ WARNING

- Never transport children on the front seat of a vehicle without using a proper restraint system. If airbags are deployed in the event of an accident, the child might suffer severe or even fatal injuries!
- For the driver and front passenger it is important to maintain a distance of at least 25 cm from the steering wheel or dash panel ⇒ fig. 137. Not maintaining this minimum distance will mean that the airbag system will not be able to properly protect you - hazard! The front seats and the head restraints must always also be correctly adjusted to match the body size of the occupant.
- It is essential to always switch off ⇒ page 151, "Deactivating an airbag" the front passenger airbag when attaching a child safety seat on the front passenger seat where the child is seated with its back facing in direction of travel (in some countries also when the child is facing the direction of travel). If this is not done, there is a risk of the child suffering severe or even fatal injuries if the front passenger airbag is deployed. In certain countries national legal provisions also require that the side or head passenger airbags be deactivated. When transporting a child on the front passenger seat, please comply with the appropriate national regulations regarding the use of child safety seats.
- There must not be any further persons, animals or objects positioned between the front seated occupants and the deployment area of the airbag.
- The steering wheel and the surface of the airbag module in the dash panel on the passenger side must not be stuck onto, covered or modified in any other way. These parts should only be cleaned with a dry cloth or a cloth moistened with water. No objects such as cup holders, mobile phone mounts, etc. may be

⚠ WARNING (continued)

attached to the covers of the airbag modules or be located within the immediate area.

- No modifications of any kind may be made to parts of the airbag system. Any work on the airbag system including installing and removing system components because of other repair work (e.g. removing the steering wheel) must only be carried out by a specialist garage.
- Never carry out changes on the front bumper or on the body.
- Never place any objects on the surface of the front passenger airbag module in the dash panel. ■

Side airbags

Description of side airbags

The side airbag increases protection of the passenger concerned in the case of a side impact.

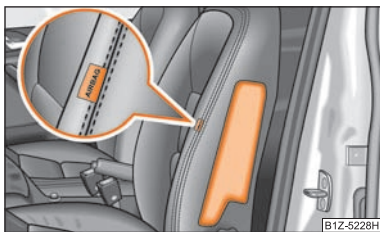

Fig. 138 Driver seat: Installation position of airbag

The side airbags are housed in the upholstery of the seat backrests of the front seats and are marked with the lettering "AIRBAG" ⇒ fig. 138 on the middle part.

The side airbag system in combination with the three-point seat belts, offers additional protection for the upper area of the body (chest, stomach and pelvis) of the occupants of the vehicle in the event of severe side collisions ⇒ page 149.

Apart from their normal protective function, a further task of the **seat belts** is to also hold the driver and front passenger in a correct seated position in the event of a side collision so as to enable the side airbags to offer the maximum protection.

You should therefore always fasten the seat belts, not only because this is required by law, but also for safety reasons and for your own protection. ■

Function of the side airbags

Risk of injury to the upper part of the body is reduced by fully inflated side airbags.



Fig. 139 Inflated side airbag

When the side airbags are deployed, the head airbag and the belt tensioner are also automatically deployed on the relevant side.

In certain accident situations, the front, side and head airbag are simultaneously deployed.

If an airbag is deployed, the airbag is filled with gas. The airbags inflate in fractions of a second and at a high speed in order to be able to offer that additional protection in the event of an accident ⇒ fig. 139.

A grey white, non harmful gas is released when airbag is inflated. This is perfectly normal and is not an indication of a fire in the vehicle.

The load of the occupants is cushioned when plunging into the fully inflated airbag and the risk of injury to the entire upper body (chest, stomach and pelvis) is reduced on the side facing the door. ■

Important safety information on the side airbag

Correct use of the airbag system considerably reduces the risk of injury!

WARNING

- It is essential to always switch off ⇒ page 151, "Deactivating an airbag" the front passenger airbag when attaching a child safety seat on the front passenger seat where the child is seated with its back facing in direction of travel (in some countries also when the child is facing the direction of travel). If this is not done, there is a risk of the child suffering severe or even fatal injuries if the front passenger airbag is deployed. When transporting a child on the front passenger seat, please comply with the appropriate national regulations regarding the use of child safety seats.
- Your head should never be positioned in the deployment area of the side airbag. You might suffer severe injuries in the event of an accident. This applies in particular to children who are transported without using a suitable child safety seat ⇒ page 155, "Child safety and side airbag".
- If children adopt an incorrect seated position when travelling, they may be exposed to an increased risk of injury in the event of an accident. This can result in serious injuries ⇒ page 153, "What you should know about transporting children!".
- There must not be any further persons, animals as well as objects positioned between the occupants and the deployment area of the airbag. No accessories, such as a can holder, should be attached to the doors.
- The airbag control unit operates together with the pressure sensors, which are attached in the front doors. For this reason no adjustments must be carried out at the doors as well as at the door panels (for example additional installation of loudspeakers). Resulting damages can have a negative effect on the operation of the airbag system. All work on the front doors and their panels must only be carried out by a specialist garage.
- In the event of a side collision, the side airbags will not function properly, if the sensors cannot measure the increasing air pressure inside the doors, because the air can escape through large, non-sealed openings in the door panel.
 - Never drive with removed inner door panels.
 - Never drive, if parts of the inner door panel have been removed and the remaining openings have not been properly sealed.
 - Never drive, if the loudspeakers in the doors have been removed, only if the loudspeaker openings have been properly sealed.

WARNING (continued)

- Always make sure that the openings are covered or filled, if additional loudspeakers or other equipment parts are installed in the inner door panels.
- Always work with an authorised Škoda dealer or have it carried out by a competent specialist workshop.
- Only hang light items of clothing on the clothes hooks to the vehicle. Never leave any heavy or sharp-edged objects in the pockets of the items of clothing.
- Ensure that there are no excessive forces, such as violent knocks, kicks etc., impact on the backrests of the seats otherwise the system may be damaged. The side airbags would not be deployed in such a case!
- Any seat or protective covers which you fit to the driver or front passenger seats must only be of the type expressly authorized by Škoda Auto. In view of the fact that the airbag inflates out of the backrest of the seat, use of non-approved seat or protective covers would considerably impair the protective function of the side airbag.
- Any damage to the original seat covers in the area of the side airbag module must be repaired without delay by your specialist garage.
- The airbag modules in the front seats must not display any damage, cracks or deep scratches. It is not permissible to use force in order to open the modules.
- Any work on the side airbag system including removing and installing system components because of other repair work (e.g. removing seats) must only be carried out by a specialist garage. ■

Head airbags

Description of the head airbags

The head airbag together with the side airbag offers enhanced occupant protection in the event of a side collision.



Fig. 140 Installation position of the head airbags

The head airbags are positioned above the doors on both sides in the interior of the car ⇒ fig. 140. The installation positions of the head airbags are each marked with the "AIRBAG" logo.

The head airbag together with the three-point seat belts and the side airbags, offers additional protection for the head and neck area of the occupants in the event of a side collision of major severity ⇒ page 151, "Important safety information on the head airbag".

Apart from their normal protective function, a further task of the **seat belts** is to also hold the driver and the occupants in a correct seated position in the event of a side collision so as to enable the head airbags to offer the maximum protection. You should therefore always fasten the seat belts, not only because this is required by law, but also for safety reasons and for your own protection ⇒ page 141, "Why seat belts?".

Together with other elements (such as cross bars in the doors, stable vehicle structure) the head airbags are the consequent further development of occupant protection in the case of side collisions. ■

Function of the head airbags

The risk of injury to the head and neck area is reduced in the event of a side collision by fully inflated head airbags.

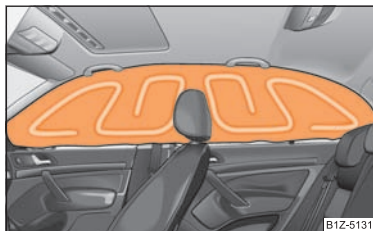

Fig. 141 Inflated head airbag

In the case of a **side collision** the head airbag is deployed together with the relevant side airbag ⇒ fig. 141 and the belt tensioner on the side of the car on which the accident occurs.

If the system is deployed, the airbag is filled with propellant gas and covers the entire area of the side window including the door pillars ⇒ fig. 141.

The protection offered by the head airbags is thus available simultaneously both to the front occupants of the car seated on the side on which the collision occurs, as well as to the rear occupants. Any impact of the head against parts of the interior or objects outside of the car, is cushioned by the inflated head airbag. The reduction in any impact to the head and the resultant minimizing of any movements of the head additionally reduce the risk of injuries to the neck area. The head airbag also offers additional protection in the case of an offset impact by covering the front door pillar.

In certain accident situations, the front, side and head airbag are simultaneously deployed.

The airbags inflate in fractions of a second and at a high speed in order to be able to offer that additional protection in the event of an accident. A grey white, non harmful gas is released when airbag is inflated. This is perfectly normal and is not an indication of a fire in the vehicle. ■

Important safety information on the head airbag

Correct use of the airbag system considerably reduces the risk of injury!

WARNING

- It is essential to always switch off ⇒ page 151, "Deactivating an airbag" the front passenger airbag when attaching a child safety seat on the front passenger seat where the child is seated with its back facing in direction of travel (in some countries also when the child is facing the direction of travel). If this is not done, there is a risk of the child suffering severe or even fatal injuries if the front passenger airbag is deployed. When transporting a child on the front passenger seat, please comply with the appropriate national regulations regarding the use of child safety seats.
- There must not be any objects in the deployment area of the head airbags which might prevent the airbags from inflating properly.
- Only hang light items of clothing on the clothes hooks to the vehicle. Never leave any heavy or sharp-edged objects in the pockets of the items of clothing. In addition, it is not permitted to use clothes hangers for hanging up items of clothing.
- The airbag control unit operates together with the sensors, which are attached in the front doors. For this reason no adjustments must be carried out at the doors as well as at the door panels (for example additional installation of loudspeakers). Resulting damages can have a negative affect on the operation of the airbag system. All work on the front doors and their panels must only be carried out by a specialist garage.
- There must not be any other persons (e.g. children) or animals between the car occupant and the deployment area of the head airbag. In addition, none of the occupants should lean their head out of the window when driving, or extend their arms and hands out of the window.
- The sun visors must not be swivelled to the side windows into the deployment area of the head airbags if any objects, such as ball-point pens etc. are attached to them. This might result in injuries to the occupants if the head airbag is deployed.
- Installing impermissible accessories in the area of the head airbags may considerably impair the protection offered by the head airbag in the event of it being deployed. When the deployed head airbag is inflated, parts of the accessories fitted may in certain circumstances be thrown into the interior of the car and cause injuries to the occupants ⇒ page 204, "Accessories, changes and replacement of parts".

WARNING (continued)

- Any work on the head airbag system including installing and removing system components because of other repair work (e.g. removing headliner) must only be carried out by a specialist garage. ■

Deactivating an airbag

Deactivating airbags

If any airbags have been deactivated, switch them on again as soon as possible so that they are able to again provide their proper protection.

There is the technical means installed within your vehicle to switch off the front, side or head airbag (take out of commission).

This is why you should have the deactivation of the airbags carried out by a specialist garage.

On vehicles equipped with the switch for deactivation of the airbags, you can deactivate the front passenger airbag by means of this switch ⇒ page 152.

Deactivation of airbags is envisaged only for particular instances, such as if:

- You must in **exceptional cases** use a child seat on the front passenger seat where the child is seated with its back to the direction of travel (in some countries this must be in the direction of travel due to other legal regulations applying) ⇒ page 153, "Important safety information regarding the use of child safety seats";
- you are not able to maintain the distance of at least 25 cm between middle of steering wheel and chest, despite the driver seat being correctly adjusted;
- special attachments are required in the area of the steering wheel because of a physical disability;
- you have installed other seats (e.g. orthopaedic seats without side airbags).

Monitoring the airbag system

The functionality of the airbag system is also monitored electronically when one airbag has been switched off.

If the airbag was switched off using diagnostic equipment:

- The warning light for the airbag system lights up for 4 seconds after switching on the ignition and then flashes for 12 seconds afterwards in 2 second intervals. ▶

The following situation applies if the airbag has been switched off using the switch for the airbag in the storage compartment:

- the airbag indicator light in the instrument cluster comes on for about 4 seconds each time the ignition is switched on,
- if the airbags are switched off, this is indicated in the middle of the dash panel by the lighting up of the indicator light **AIRBAG OFF** ⇒ fig. 142 - right.



Note

Your authorised Škoda Service Partner will be able to advise you whether national legislation in your country allows airbags in your vehicle to be deactivated, and which ones. ■

Switch for the front passenger airbag

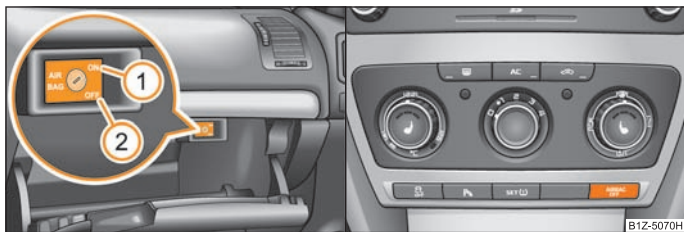

Fig. 142 Storage compartment: Switch for the front passenger airbag/indicator light for a switched off front seat passenger airbag

Only the front passenger airbag is deactivated with the switch.

Deactivating an airbag

- Switch off the ignition.
- Turn the slot of the airbag switch using the key in the position ② (OFF) ⇒ fig. 142.
- Check whether the indicator light **AIRBAG OFF** in the middle of the dash panel lights up when the ignition is switched on ⇒ fig. 142 - right.

Switching on an airbag

- Switch off the ignition.

- Turn the slot of the airbag switch using the key in the position ① (ON) ⇒ page 152, fig. 142.
- Check whether the airbag indicator light **AIRBAG OFF** in the middle of the dash panel lights up when the ignition is switched on ⇒ page 152, fig. 142 - right.

The airbag should only be switched off under exceptional circumstances ⇒ page 151.

Indicator light **AIRBAG OFF** (airbag switched off)

The airbag indicator light is located in the middle of the dash panel ⇒ page 152, fig. 142 - right.

If the front passenger airbag is switched off, the warning light comes on about 4 seconds after the ignition is switched on.

There is a system fault present in the airbag switch off ⇒ ⚠ if the indicator light flashes. **Please have the car inspected immediately by a specialist garage.**



WARNING

- The driver is responsible for whether the airbag is switched on or switched off.
- Only switch off the airbag when the ignition is switched off! Otherwise a fault can occur in the system for the airbag deactivation.
- If the warning light **AIRBAG OFF** (airbag switched off) flashes:
 - Front passenger airbag is not deployed in the event of an accident!
 - It is also important to have the system inspected without delay by a specialist garage. ■

Transporting children safely

What you should know about transporting children!

An introduction to the subject

Accident statistics have revealed that children are generally more safely transported on the rear seats than on the front passenger seat.

Children who are less than 1.50 m in height and who weigh less than 36 kg should, under normal circumstances, sit on the rear seat (take note of any national legal provisions which differ from this). They should be secured there by means of a child restraint system or by using the existing seat belts depending on their body size and weight. The child seat should be mounted behind the front passenger seat for safety reasons.

The physical principle of an accident does, of course, also apply to children ⇒ page 141, "The physical principle of a frontal collision". They differ from adults in that their muscles and bone structure of children are not yet fully developed. Thus children are exposed to increased risk of injury.

Children should be transported by using special child safety seats in order to reduce this risk of injury!

Only use child safety seats which are officially approved, suitable for children and which comply with the standard ECE-R 44, which classifies child safety seats into 5 groups ⇒ page 155, "Classification of child seats into groups". Child restraint systems which have been tested for conformity to ECE-R 44 standard have a non-detachable test seal (a large E within a circle and below this the test number) attached to the seat.

We recommend that you use child safety seats from the Škoda genuine accessories range. These child seats were developed and also tested for use in Škoda vehicles. They fulfil the ECE-R 44 standard.

WARNING

Always comply with national legal provisions and instructions from the relevant child safety seat manufacturer when installing and using a child seat ⇒ page 153.

Note

National legal provisions, which deviate from the information contained in these operating instructions, take precedence over the information contained in the operating instructions. ■

Important safety information regarding the use of child safety seats

Correct use of child safety seats considerably reduces the risk of injury!

WARNING

- All the occupants of the car - in particular children - must wear a seat belt when the car is moving.
- Children who are less than 1.50 m in height and who weigh less than 36 kg must not use a normal seat belt without a child restraint system, otherwise this may result in injuries to the stomach and neck areas. Comply with the national legal requirements.
- One should never carry children, and also not babies! - on one's lap.
- You can transport a child safely in a suitable child safety seat ⇒ page 155, "Child seat"!
- Only one child may be fastened with a seat belt into a child safety seat.
- Never leave the child sitting unattended in the seat.
- Certain outside climatic conditions can cause life-threatening temperatures in the vehicle.
- Never allow your child to be transported in a vehicle without the use of a suitable restraint system.
- Children should also never stand up in a vehicle or kneel on the seats when the vehicle is moving. In the event of an accident the child will be thrown through the vehicle and may as a result suffer fatal injuries, and also injure other occupants.
- Children are exposed to an increased risk of injury in the event of an accident if they lean forward or adopt an incorrect seated position when the vehicle is moving. This particularly applies to children who are transported on the front passenger seat if the airbag system deploys in the event of an accident. This can result in severe or even fatal injuries.

⚠ WARNING (continued)

- It is important that the belt webbing is properly routed if the seat belts are to offer their maximum protection ⇒ page 143, "How are seat belts correctly fastened?". Pay particular attention to the information provided by the manufacturer of the child safety seat regarding correct routing of the belt. Seat belts which are not correctly adjusted can themselves cause injuries even in minor accidents.
- Safety belts must be checked to ensure that they are running properly. One should also ensure that the belt is not damaged by sharp-edged fittings.
- It is essential to always switch off the front passenger airbag when attaching a child safety seat to the front passenger seat where the child is seated with its back facing in direction of travel ⇒ page 152. If this is not done, there is a risk of the child suffering severe or even fatal injuries if the front passenger airbag is deployed. When transporting a child on the front passenger seat, please comply with the appropriate national regulations regarding the use of child safety seats. ■

Use of child safety seats on the front passenger seat

Child safety seats should always be attached to the rear seats.

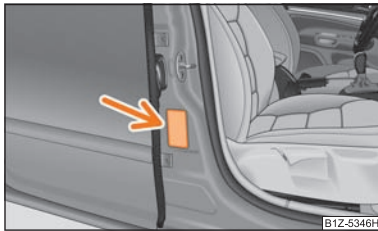

Fig. 143 Sticker on the centre column of the body on the front passenger side.

We recommend, for safety reasons, that you always mount a child restraint systems on the rear seats whenever possible. If you still decide, however, to use a child safety seat on the front passenger seat then you must pay attention to the following warnings in connection with the use of the airbag system on the front passenger seat.

⚠ WARNING

- **Warning - particular hazard!** Never use a child safety seat on the front passenger seat in which the child is seated with its back facing the direction of travel. This child safety seat is positioned in the deployment area of the front passenger airbag. The airbag may cause the child severe, or even fatal injuries, in the event of it being deployed.
- This is also clearly stated on the sticker which is located on the centre column of the body on the front passenger side ⇒ **fig. 143**. The sticker is visible upon opening the front passenger door. For some countries, the sticker is also affixed to the sun visor of the front passenger.
- It is essential to always switch off the front passenger airbag when a child safety seat is nevertheless attached to the front passenger seat where the child is seated with its back facing in direction of travel ⇒ page 151, "Deactivating an airbag". If this is not done, there is a risk of the child suffering severe or even fatal injuries if the front passenger airbag is deployed. When transporting a child on the front passenger seat, please comply with the appropriate national regulations regarding the use of child safety seats.
- If the front passenger airbag has been switched off by a specialist garage using the vehicle system tester, the side and head passenger airbag remains switched on. Please comply with any differing national legal regulations regarding the use of child safety seats.
- If a child safety seat in which the child faces in the direction of travel is used on the front passenger seat, the front passenger seat must be moved back and to the top fully. Move the seat backrest into the vertical position.
- You should have the front passenger airbag (or airbags) reactivated just as soon as you no longer use a child safety seat on the front passenger seat. ■

Child safety and side airbag

Children must never be seated in the deployment area of the side airbags and head airbags.



Fig. 144 Seated position of an unprotected child at risk from side airbag/Child properly protected by safety seat

In the event of a side collision, the side airbags offer the vehicle occupants enhanced protection.

The side airbags are inflated in fractions of a second in order to be able to provide this protection ⇒ page 148, "Function of the side airbags".

The airbag develops such a strong force that an occupant who has not adopted an upright seated position may suffer injuries from the airbag or as a result of objects which are located within the deployment area of the side airbag.

This applies particularly to children if they are not transported in accordance with legal requirements.

The child is protected when seated in a child safety seat matching its age. Adequate room is available between the child and the deployment area of the side airbag and head airbag. The airbag offers optimal protection.

WARNING

- It is essential to always switch off ⇒ page 151 the front passenger airbag when attaching a child safety seat on the front passenger seat where the child is seated with its back facing in direction of travel (in some countries also when the child is facing the direction of travel). If this is not done, there is a risk of the child suffering severe or even fatal injuries if the front passenger airbag is deployed. When transporting a child on the front passenger seat, please comply with the appropriate national regulations regarding the use of child safety seats.

WARNING (continued)

- When transporting a child on the front passenger seat, please comply with the appropriate national regulations regarding the use of child safety seats.
- Children must never be seated with their head in the deployment area of the side airbag - risk of injury!
- Do not place any objects within the deployment area of the side airbag - risk of injury! ■

Child seat

Classification of child seats into groups

Only child safety seats which have an official approval and are suitable for the child, may be used.

ECE-R 44 standard applies to child safety seats. ECE-R means: Economic Commission for Europe - Regulation.

Child safety seats which have been tested for conformity to ECE-R 44 standard have a non-detachable test seal (a large E within a circle and below this the test number) attached to the seat.

Child safety seats are classified in 5 groups:

Group	Weight	
0	0 - 10 kg	⇒ page 156
0+	up to 13 kg	⇒ page 156
1	9 - 18 kg	⇒ page 156
2	15 - 25 kg	⇒ page 157
3	22 - 36 kg	⇒ page 157

Children who are more than 1.50 m in height or who weigh more than 36 kg can use normal seat belts without a seat bolster. ■

Use of child seats

An overview of the usefulness of child seats on each of the seats according to the ECE-R 44 standard:

Child seat of the group	Front passenger seat	Rear seat outside	Rear seat middle
0	Ⓚ ⊕	Ⓚ ⊕ ⊕	Ⓚ
0+	Ⓚ ⊕	Ⓚ ⊕ ⊕	Ⓚ
1	Ⓚ ⊕	Ⓚ ⊕ ⊕	Ⓚ
2 and 3	Ⓚ	Ⓚ	Ⓚ

- Ⓚ Universal category - seat is suitable for all approved types of child safety seats.
- ⊕ The seat can be fitted with fixing eyes for the "ISOFIX" system.
- ⊕ The divided rear seat - seat can be fitted with fixing eyes for the system "Top Tether" ⇒ page 158, "Attaching child seat using the "Top Tether" system". ■

Child seats of group 0/0+



Fig. 145 Child seats of group 0/0+

The optimal solution for babies of up to about 9 months old weighing up to 10 kg or children up to about 18 months old weighing up to 13 kg is a child safety seat which is fastened in the opposite direction of travel ⇒ fig. 145.

Child seats in which the child is facing with its back towards the direction of travel should not be used on the front passenger seat when the vehicle is fitted with a front passenger airbag ⇒ page 154, "Use of child safety seats on the front passenger seat".

⚠ WARNING

- It is essential to always switch off the front passenger airbag at a specialist garage or with the switch for front passenger airbag when attaching in exceptional circumstances a child safety seat on the front passenger seat where the child is seated with its back facing in direction of travel ⇒ page 152, "Switch for the front passenger airbag".
- Please comply with any differing national legal regulations regarding the use of child safety seats.
- If this is not done, a child seated on the front passenger seat may suffer severe or even fatal injuries if the front passenger airbag or airbags are deployed.
- You should have the front passenger airbag (or airbags) reactivated just as soon as you no longer use a child safety seat on the front passenger seat. ■

Child safety seats in Group 1



Fig. 146 Child seat with padded table in Group 1 installed on rear seat bench facing the direction of travel

Child seats in Group 1 are for babies and small children up to 4 years of age with a weight of between 9 and 18 kilograms. It is best for children in the lower range of this group, to use a child seat which allows the child to sit with its back to the direction of travel. It is best for children in the upper range of the Group 0+, to use a child seat which allows the child to sit ⇒ fig. 146 in the direction of travel.

Child seats in which the child is facing with its back towards the direction of travel should not be used on the front passenger seat when the vehicle is fitted with a front passenger airbag ⇒ page 154, "Use of child safety seats on the front passenger seat".

WARNING

- It is essential to always switch off the front passenger airbag at a specialist garage or with the switch for front passenger airbag when attaching in exceptional circumstances a child safety seat on the front passenger seat where the child is seated with its back facing in direction of travel ⇒ page 152, "Switch for the front passenger airbag".
- Please comply with any differing national legal regulations regarding the use of child safety seats.
- If this is not done, a child seated on the front passenger seat may suffer severe or even fatal injuries if the front passenger airbag or airbags are deployed.
- You should have the front passenger airbag (or airbags) reactivated just as soon as you no longer use a child safety seat on the front passenger seat. ■

Child safety seats in Group 2

Fig. 147 Child seat in Group 2 installed on the rear seat facing the direction of travel

For children up to about 7 years of age weighing between 15 and 25 kg the optimal solution is a child safety seat in combination with the three-point seat belt ⇒ fig. 147.

WARNING

- When transporting a child on the front passenger seat, please comply with the appropriate national regulations regarding the use of child safety seats. Switch off the front passenger airbag if necessary at a specialist garage or switch it off with the switch for front passenger airbag ⇒ page 152, "Switch for the front passenger airbag".

WARNING (continued)

- The shoulder part of the seat belt must run approximately across the middle of the shoulder and fit snugly against the chest. It must on no account run across the neck. The lap part of the seat belt must run across the pelvis and fits snugly; it must not run over the belly. Tighten the belt webbing over your hip if necessary.
- Please comply with any differing national legal regulations regarding the use of child safety seats. ■

Child safety seats in Group 3

Fig. 148 Child seat in Group 3 installed on the rear seat facing the direction of travel

For children of about 7 years of age weighing between 22 and 36 kg and of a height of less than 150 cm, the optimal solution is a child safety seat (seat bolster) in combination with the three-point seat belt ⇒ fig. 148.

Children who are more than 1.50 m in height or who weigh more than 36 kg can use normal seat belts without a seat bolster.

WARNING

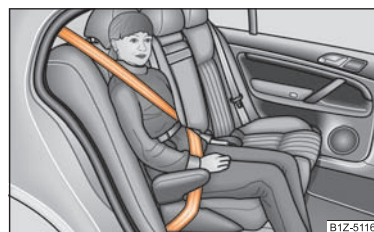
- When transporting a child on the front passenger seat, please comply with the appropriate national regulations regarding the use of child safety seats. Switch off the front passenger airbag if necessary at a specialist garage or switch it off with the switch for front passenger airbag ⇒ page 152, "Switch for the front passenger airbag".
- The shoulder part of the seat belt must run approximately across the middle of the shoulder and fit snugly against the chest. It must on no account run across the neck. The lap part of the seat belt must run across the pelvis and fits snugly; ■

⚠ WARNING (continued)

it must not run over the belly. Tighten the belt webbing over your hip if necessary.

- Please comply with any differing national legal regulations regarding the use of child safety seats. ■

Attaching a child seat using the "ISOFIX" system

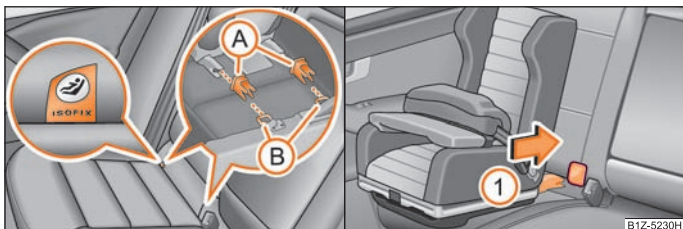

Fig. 149 Locking eyes (ISOFIX system)/Push the ISOFIX child seat into the installed mounting funnels

There are two fixing eyes between the seat backrest and the seat cushion of the front passenger seat for fixing the "ISOFIX" system child seat in place. The locking eyes on the rear outside seats are located below the upholstery. The places are marked with signs with the logo "ISOFIX" ⇒ fig. 149 - left.

Install child seat

- Open the zip fasteners between the seat cushion and the seat backrest of the rear exterior seat.
- Insert the mounting funnels (A) onto the locking eyes (B) between the seat backrest and the seat cushion ⇒ fig. 149.
- Push the notched arms of the child seat into the locking eyes in direction of arrow (1), until they are heard to lock in place ⇒ fig. 149.
- **Pull on both sides of the child seat!**

One can mount a child safety seat using the "ISOFIX" system quickly, easily and reliably. Please pay close attention to instructions from the manufacturer of the child safety seat when installing and removing the seat.

Child seats fitted with the "ISOFIX" system can only be mounted and fixed in a vehicle fitted with an "ISOFIX" system when these child seats have been released for this type of vehicle according to the ECE-R 44 standard.

Child safety seats with the fixing system "ISOFIX" can be obtained from Škoda original accessories.

Complete installation instructions are enclosed with the child safety seat.

⚠ WARNING

- The locking eyes have just been developed for child safety seats which use the "ISOFIX" system. You should therefore never attach other child safety seats, seat belts or objects to the locking eyes - hazard!
- Ask an authorised Škoda Service Partner whether a child seat which you bought for another vehicle is recommended for use in a Škoda before using an "ISOFIX" system.
- Certain child seats which use the "ISOFIX" system can be attached with standard three-point seat belts. Please pay close attention to instructions from the manufacturer of the child safety seat when installing and removing the seat.

i Note

- Child seats which use the "ISOFIX" system are currently available for children weighing up to about 18 kg. This corresponds to an age range up to 4 years.
- The child seats can also be fitted with the "Top Tether" system ⇒ page 158. ■

Attaching child seat using the "Top Tether" system

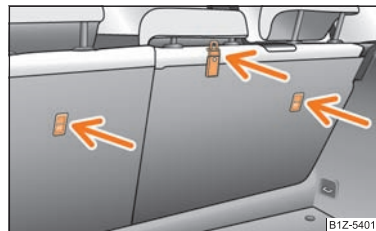

Fig. 150 Rear seat: Top Tether

In certain countries national legal provisions also require the equipment of the rear seat with fixing eyes for child seat using the "Top Tether" system ⇒ fig. 150.

Always perform the installation and removal of the child seat using the "Top Tether" system as stated in the instructions from the manufacturer of the child seat.

 **WARNING**

- Attach the child seats with the "Top Tether" system only to the points provided for this purpose ⇒ page 158, fig. 150.
- On no account should you equip your vehicle, e.g. mount screws or other anchorage points.
- Pay attention to the important safety information regarding the use of child seats.

 **Note**

Store the remaining part of the belt for the "Top Tether" system in a textile pocket, which is located at the child seat. ■

Driving Tips

Intelligent Technology

Electronic stability programme (ESP)

General





Fig. 151 ESP system: Switch for TCS

The ESP aids you in maintaining control of your vehicle in situations in which the vehicle is driving at its dynamic limits, such as entering a curve fast. The risk of skidding is reduced and your car thus offers greater driving stability depending on the conditions of the road surface. The system operates at all speeds.

The following systems are integrated into the electronic stability programme:

- Electronic Differential Lock (EDL),
- Traction control system (TCS),
- active driver-steering recommendation (DSR),
- Antilock brake system (ABS),
- Brake Assist,
- Uphill Start Assist.

The ESP system cannot be switched off with the  \Rightarrow fig. 151 button; only the TCS system is switched off, the warning light  instrument cluster lights up.

Operating principle

The ESP switches on automatically when the engine is started and then conducts a self-test. The ESP control unit processes data from the individual systems. It also processes additional measurement data which are supplied by highly sensitive

sensors: the rotational velocity of the vehicle about its vertical axis, the lateral acceleration of the vehicle, the braking pressure and the steering angle.

The direction which the driver wishes to take is determined based on the steering angle and the speed of the vehicle and is constantly compared with the actual behaviour of the vehicle. If differences exist, such as the car beginning to skid, the ESP will automatically brake the appropriate wheel.

The car is stabilised again by the forces which take effect when the wheel is braked. Intervention into the brake system takes place primarily on the outer front wheel of a vehicle which tends to oversteer (tendency for the rear of the vehicle to break away) while occurs this is on the inner rear wheel of a vehicle which tends to understeer (tendency to shift out of the curve). This braking control cycle is accompanied by noises.

During an intervention of the system, the warning light  flashes in the instrument cluster \Rightarrow page 31.

The ESP operates in combination with the ABS \Rightarrow page 164, "Antilock brake system (ABS)". If there is a fault in the ABS system, the ESP also does not operate.

The ESP warning light lights up in the instrument cluster when there is a fault on the ESP  \Rightarrow page 31.

WARNING

It is also not possible for the ESP to overcome the physical limits of the vehicle. Even if a vehicle fitted with ESP you should still always adapt your style of driving to the condition of the road surface and the traffic situation. This particularly applies when driving on slippery and wet roads. The increased safety offered must not tempt you to take greater risks than otherwise - risk of an accident!

Note

- All four wheels must be fitted with the same tyres in order to achieve problem-free operation of the ESP. Differing rolling circumferences of the tyres can lead to an undesirable reduction in the engine output. 

- Changes to vehicle (e.g. on engine, on the brakes, on chassis or another combination of tyres and wheels) can influence the function of the ESP ⇒ page 204, "Accessories, changes and replacement of parts". ■

Electronic Differential Lock (EDL and XDL)

The electronic differential lock prevents an individual wheel from slipping.

General

The EDL makes it much easier, and sometimes at all possible, to start off, accelerate and climb a steep hill when the conditions of the road surface are unfavourable.

Operating principle

The EDL is activated automatically, that is without any action on the part of the driver. It monitors the speeds of the driven wheels with the aid of the ABS sensors. Should only **one** drive wheel begin spinning on a slippery surface there will be an appreciable difference in the speed of the driven wheels. The EDL function brakes the slipping wheel and the differential transmits a greater driving force to the other driven wheel. This control process is also accompanied by noises.

Overheating of the brakes

The EDL switches off automatically if unusually severe stresses exist in order to avoid excessive heat generation in the disc brake on the wheel which is being braked. The vehicle can continue to be driven and has the same characteristics as a vehicle not fitted with EDL.

The EDL switches on again automatically as soon as the brake has cooled down.

XDL function (only for Octavia RS)

The XDL function is an extension to the electronic differential lock. The XDL function does not respond to traction, but to the relief of the inner front wheel during fast cornering. An active brake intervention on the brake of the inner wheel prevents it from spinning. Thus, the traction is improved and the vehicle continues to follow the desired track.

WARNING

- **Carefully depress the accelerator when accelerating on uniformly slippery road surfaces, such as ice and snow. The driven wheels might still spin despite the EDL and affect the stability of the vehicle - risk of an accident!**
- **You should always adapt your style of driving to the condition of road surface and to the traffic situation even when your vehicle is fitted with EDL. The**

WARNING (continued)

increased safety offered must not tempt you to take greater risks than otherwise - risk of an accident!

Note

- If the ABS or ESP warning light comes on, this may also indicate a fault in the EDL. Have the vehicle inspected by your specialist garage as soon as you can.
- Changes to vehicle (e.g. on engine, on the brakes, on chassis or another combination of tyres and wheels) can influence the function of the EDL ⇒ page 204, "Accessories, changes and replacement of parts". ■

Traction control system (TCS)

The traction control system prevents the driven wheels from spinning when accelerating.



Fig. 152 TCS switch

General

The TCS makes it much easier, and sometimes at all possible, to start off, accelerate and climb a steep hill when the conditions of the road surface are unfavourable.

Operating principle

The TCS switches on automatically when the engine is started and then conducts a self-test. The system monitors the speeds of the driven wheels with the aid of the ABS sensors. If the wheels are spinning, the force transmitted to the road surface is automatically adapted by reducing the engine speed. The system operates at all speeds.

The TCS operates in combination with the ABS ⇒ page 164, "Antilock brake system (ABS)". The TCS will not function if a fault exists in the ABS system. ▶

The TCS warning light lights up in the instrument cluster when there is a fault on the TCS  ⇒ page 31.

During an intervention of the system, the TCS warning light flashes  in the instrument cluster ⇒ page 31.

Switching off

You can also switch off the TCS system by pressing the ⇒ page 162, fig. 152 button, or, in vehicles with ESP, by pressing the ⇒ page 161, fig. 151 button. The TCS warning light lights up in the instrument cluster when the TCS is switched off .

The TCS should normally always be switched on. It may be good practice in certain exceptional cases, such as when you wish to have wheel slip, to switch off the system.

Examples:

- when driving with snow chains
- when driving in deep snow or on a loose surface
- when it is necessary to rock a car free when it has become stuck.

then you should switch on the TCS again.

WARNING

You should always adjust your style of driving to the conditions of the road surface and the traffic situation. The increased safety offered must not tempt you to take greater risks than otherwise - risk of an accident!

Note

- All four wheels must be fitted with the same tyres in order to achieve problem-free operation of the TCS. Differing rolling circumferences of the tyres can lead to an undesirable reduction in the engine output.
- Changes to vehicle (e.g. on engine, on the brakes, on chassis or another combination of tyres and wheels) can influence the function of the TCS ⇒ page 204, "Accessories, changes and replacement of parts". ■

Active driver-steering recommendation (DSR)

This function indicates to the driver in critical situations a steering recommendation in order to stabilise the vehicle. The active driver-steering recommendation is activated, for example, on the right and left vehicle side when braking sharply on different road surfaces.

WARNING

Even with this function the vehicle cannot steer itself! The driver is furthermore responsible for the steering of the vehicle! ■

Brakes

What has a negative effect on braking efficiency?

Wear-and-tear

Wear-and-tear to the brake pads is greatly dependent on the operating conditions of the vehicle and your style of driving. Particularly if you drive a great deal in towns and over short distances or if you adopt a sporty style of driving, it may be necessary to have the thickness of the brake pads inspected at a specialist garage between the service inspections.

Wet roads or road salt

There may be a certain delay before the brakes take full effect under certain conditions such as when driving through water, during heavy rain showers or after the vehicle has been washed in an automatic vehicle wash, since the brake discs and brake pads may be moist or even have a coating of ice on them in winter. You should dry the brakes as soon as possible by applying and releasing the brakes several times.

There also may be a certain delay before the full braking efficiency is available when driving on roads which have been treated with road salt if you have not used the brakes for some considerable time beforehand. The layer of salt on the brake discs and brake pads must first be rubbed off when you apply the brakes.

Corrosion

Corrosion on the brake discs and dirt on the brake pads occur if the vehicle has been parked for a long period and if you do not make much use of the braking system.

We recommend cleaning the brake discs by firmly applying the brakes at a fairly high speed if you do not make much use of the braking system or if surface corrosion is present ⇒ .

Faults in the brake surface

If you notice that the braking distance has suddenly become longer and that the brake pedal can be depressed further, it is possible that a brake circuit of the dual-circuit brake system has failed. Drive, in such cases, to the nearest specialist garage without delay in order to have the problem rectified. Drive at a reduced speed while on your way to the dealer and adapt your style of driving to the higher brake pedal pressure required. ►

Low brake fluid level

An insufficient level of brake fluid may result in problems in the brake system. The level of the brake fluid is monitored electronically → page 33, "Brake system ⓘ".



WARNING

- Only apply the brakes for the purpose of drying and cleaning the brake discs if the traffic conditions permit this. Do not place any other road users in jeopardy.
- When retrospectively mounting a front spoiler, solid wheel hubs etc. one must ensure that the air supply to the front wheel brakes is not reduced otherwise the braking system could run too hot.
- Allow for the fact that new brake pads do not achieve their full braking efficiency until approximately 200 kilometres. New brake pads must be first "run in" before they develop their optimal friction force. You can, however, compensate for this slightly reduced braking force by increasing the pressure on the brake pedal. This guideline also applies to any new brake pads installed at a future date.



Caution

- Never allow the brakes to rub by applying slight pressure if you do not wish to brake the vehicle. This causes the brakes to overheat and can also result in a longer braking distance and excessive wear.
- Before negotiating a steep downhill section, please reduce your speed, shift down into the next lower gear (manual gearbox) or select a lower driving stage (automatic gearbox). This enables you to make full use of the braking power of the vehicle and reduces the strain on the brakes. Any additional braking should be done intermittently, not continuously.



Note

The brake light flashes automatically in case of an emergency braking at speeds greater than 60 km/h or with the intervention of the ABS, which lasts longer than 1.5 seconds. After the speed was reduced below 10 km/h or the vehicle was stopped, the brake light stops flashing and the hazard warning light system switches on. The hazard warning light system is switched off automatically after accelerating or driving off again. ■

Brake booster

The brake booster boosts the pressure which you generate with the brake pedal. The necessary pressure is only generated when the engine is running.



WARNING

- Never switch off the engine before the vehicle is stationary.
- The brake booster only operates when the engine is running. Greater physical effort for braking is required when engine is switched off. Because if you do not stop as normal, this can cause an accident and severe injuries.
- While stopping or braking with a vehicle with a petrol engine and manual transmission in the low rev range, press down on the clutch pedal. If you fail to do so, the result may be an impairment of the function of the power brake. You will apply a greater force to the brake pedal which you are used to - danger of accident! ■

Antilock brake system (ABS)

ABS prevents the wheels locking when braking.

General

The ABS contributes significantly to enhancing the active safety of your vehicle. Compared to a car not fitted with the ABS brake system, you are able to retain optimal steering ability even during a full brake application on a slippery road surface because the wheels do not lock up.

You must not expect, however, that the braking distance will be shorter under all circumstances as a result of the ABS. The braking distance for example on gravel and fresh snow, when you should anyway be driving slowly and cautiously, will be longer.

Operating principle

The brake pressure will be reduced on a wheel which is rotating at a speed which is too low for the speed of the vehicle and tending to lock. This control cycle is noticeable from a **pulsating movement of the brake pedal** which is accompanied by noises. This is consciously intended to provide the driver with the information that the wheels are tending to lock (ABS control range). You must always keep the brake pedal depressed to enable the ABS to optimally control the brake application in this braking range. Never interrupt the application of the brakes! ▶

As soon as the vehicle speed has increased to about 20 km/hour an automatic test procedure is conducted during which you will be able to hear a pumping noise for about 1 second.

WARNING

- The ABS can also not overcome the physical limits of your vehicle. Please do not forget this, particularly when driving on icy or wet road surfaces. If the ABS is operating within the control range, adapt your speed immediately to the conditions of the road surface and the traffic situation. The increased safety offered by the ABS must not tempt you to take greater risks than otherwise - risk of an accident!
- The normal braking system is still fully functional if there is an ABS fault. Visit a specialist garage immediately and adjust your style of driving according to the damage to the ABS as you will not know how great the damage is and the limitation it is placing on the braking efficiency.

Note

- A warning light comes on if a fault occurs in the ABS system  ⇒ page 32.
- Changes to vehicle (e.g. on engine, on the brakes, on chassis or another combination of tyres and wheels) can influence the function of the ABS ⇒ page 204, "Accessories, changes and replacement of parts". ■

Brake Assist

During a severe brake application (e.g. if a hazard exists), the Brake Assist increases the braking force and thus makes it possible to rapidly produce the pressure required in the brake system.

The majority of drivers do apply the brakes in good time in dangerous situations, but do not depress the brake pedal with sufficient pressure. Consequently, it is not possible for the car to achieve its maximum deceleration and the car covers a greater distance than necessary.

The Brake Assist is activated by the very quick operation of the brake pedal. In such cases, a much greater braking pressure exists than during a normal brake application. This makes it possible, even with a relatively low resistance of the brake pedal, to produce an adequate pressure in the brake system in the shortest possible time, which is required for maximum deceleration of the car. You must apply the brake pedal firmly and hold it in this position in order to achieve the shortest possible braking distance.

The Brake Assist is able to help you achieve a shorter braking distance in emergency situations by rapidly producing the pressure required in the brake system. It fully exploits the attributes of the ABS. After you release the brake pedal, the function of the Brake Assist is automatically switched off and the brakes operate in the normal way.

The Brake Assist is part of the ESP system. If a fault occurs in the ESP, the Brake Assist function is also not available. Further information on the ESP ⇒ page 161.

WARNING

- The Brake Assist is also not able to overcome the physical limits of your car in terms of the braking distance required.
- Adapt your speed to the conditions of the road surface and to the traffic situation.
- The increased safety offered by the Brake Assist must not tempt you to take a greater safety risk than otherwise. ■

Uphill Start Assist

The uphill start assist makes it easier to start off on steep hills. The system assists a start off by holding the brake pressure produced by the brake pedal actuation for approx. 2 seconds after releasing the brake pedal. The driver can therefore move his foot from the brake pedal to the accelerator pedal and start off on the slope, without having to actuate the handbrake. The brake pressure drops gradually the more you operate the accelerator pedal. If the vehicle does not start off within 2 seconds, it starts to roll back.



The uphill start assist is active as of a 5 % slope, if the driver door is closed. It is always active on slopes when in forward or reverse start off. When driving downhill, it is inactive. ■

Electromechanical power steering

The power steering enables you to steer the vehicle with less physical force.

With the electromechanical power steering, the steering assist is automatically adapted to the speed and to the steering angle.

It is still possible to fully steer the vehicle if the power steering fails or if the engine is not running (vehicle being towed in). The only difference is that greater physical effort is required. ▶

If there is a fault in the power steering, the warning light  or  lights up in the instrument cluster \Rightarrow page 29.



WARNING

Contact your specialist garage if the power steering is defective. ■

Tyre pressure monitoring system







Fig. 153 Button for setting the tyre inflation pressure control value

The tyre pressure monitoring system compares with the aid of the ABS sensors the speed and also the rolling circumference of the individual wheels. If the rolling circumference of a wheel is changed, the warning light  in the instrument cluster \Rightarrow page 31 and an acoustic signal sounds. The rolling circumference of the tyre can change if:



- the tyre inflation pressure is too low,
- the structure of the tyre is damaged,
- the vehicle is loaded on one side,
- the wheels of an axle are loaded heavily (e.g. when towing a trailer or when driving uphill or downhill),
- snow chains are mounted,
- the temporary spare wheel is mounted,
- one wheel per axle was changed.

Basic setting of the system

After changing the tyre inflation pressures, after changing one or several wheels, the position of a wheel on the vehicle (e.g. exchanging the wheels between the axles) or when the warning light lights up while driving, a basic setting of the system must be carried out as follows.

- Inflate all tyres to the specified inflation pressure \Rightarrow page 199.
- Switch on the ignition.
- Press button  \Rightarrow fig. 153 for more than 2 seconds. While pressing the button, the warning light  lights up. At the same time the memory of the system is erased and the new calibration is started, which is confirmed with an audible signal and then the warning light  goes out.
- If the warning light  does not go out after the basic setting, there is a fault in the system. Have the vehicle inspected by your nearest specialist garage.

Warning light lights up



If the tyre inflation pressure of at least one wheel is insufficiently inflated in comparison to the stored basic value, the warning light  \Rightarrow  lights up.

Warning light flashes

If the warning light flashes, there is a system fault. Have the vehicle inspected by your nearest specialist garage.



WARNING

- When the warning light  lights up, immediately reduce the speed and avoid sudden steering and brake manoeuvres. Please stop the vehicle without delay at the nearest possible stop and inspect the tyres and their inflation pressures.
- The driver is responsible for the correct tyre inflation pressures. For this reason, the tyre inflation pressures must be checked regularly.
- Under certain circumstances (e.g. sporty style of driving, wintry or unpaved roads) the warning light  can be delayed or does not light up at all.
- The tyre pressure monitoring system does not take away the responsibility from the driver for the correct tyre inflation pressure.



Note

The tyre pressure monitoring system:

- does not replace the regular tyre inflation pressure control, because the system cannot detect an even pressure loss,
- cannot warn in case of very rapid tyre inflation pressure loss, e.g. in case of sudden tyre damage. In this case carefully bring the vehicle to a standstill without sudden steering movements and without sharp braking.
- In order to ensure a proper functioning of the tyre inflation pressure-control system, it is necessary to carry out the basic setting again every 10 000 km or 1x a year. ■

Diesel particle filter (diesel engine)

In the diesel particle filter the resulting soot particles are collected and burnt during the combustion of diesel fuel.

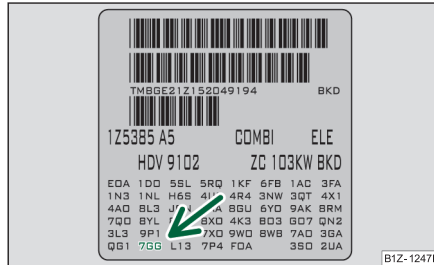



Fig. 154 Vehicle data sticker

Code **7GG**, **7MB** or **7MG** on the vehicle data sticker, see ⇒ fig. 154, indicates that your vehicle is equipped with a diesel particle filter. The vehicle data sticker is located on the floor of the luggage compartment and is also stated in the Service schedule.

The diesel particle filter filters the soot particles completely from the exhaust. The soot is collected in the diesel particle filter and burnt regularly. To assist this procedure, we recommend not to drive regularly over short distances.

If the diesel particle filter is full or there is a fault, it is indicated by the warning light .

WARNING

- The diesel particle filter achieves very high temperatures. Therefore do not park at points where the hot filter comes into direct contact with dry grass or other combustible materials - risk of fire!
- Never use additional underbody protection or corrosion-protection agents for the exhaust pipes, catalytic converters, diesel particle filter or heat shields. When the engine reaches its operating temperature, these substances might ignite - risk of fire.

Note

When using diesel fuel with high sulphur content the life of the diesel particle filter is clearly reduced. A specialist garage will be able to tell you which countries use only diesel fuel with high sulphur content. ■

Driving and the Environment

The first 1 500 kilometres and afterwards

A new engine

The engine has to be run in during the first 1 500 kilometres.

Up to 1 000 kilometres

- Do not drive faster than 3/4 of the maximum speed of the gear in use, that is 3/4 of the maximum permissible engine speed.
- Do not use full throttle.
- Avoid high engine revolutions.
- Do not tow a trailer.

From 1 000 up to 1 500 kilometres

- Increase the power output of the engine **gradually** up to the full speed of the gear engaged, that is up to the maximum permissible engine revolutions.

During the first operating hours the engine has higher internal friction than later until all of the moving parts have harmonized. The driving style which you adopt during the first approx. 1 500 kilometres plays a decisive part in the success of running in your car.

You should not drive at unnecessarily **high engine revolutions** even after the running-in period is complete. The maximum permissible engine speed is marked by the beginning of the red zone on the scale of the revolutions counter. Shift up into the next higher gear on a vehicle fitted with manual gearbox before the red zone is reached. During acceleration (depressing the accelerator) **exceptionally** high engine speeds are automatically reduced, yet the engine is not protected against too high engine speeds which are caused by incorrectly shifting down the gears resulting in a sudden increase of the engine speeds above the permitted maximum revolutions which can lead to engine damage.

For a vehicle fitted with a manual gearbox the converse situation also applies: Do not drive at engine revolutions which are **too low**. Shift down as soon as the engine is no longer running smoothly.

Caution

All the speed and engine revolution figures apply only when the engine is at its normal operating temperature. Never rev up an engine which is cold, neither when the vehicle is stationary nor when driving in individual gears.



For the sake of the environment

Not driving at unnecessarily high engine revolutions and shifting to a higher gear as early as possible are ways to minimise fuel consumption and operating noise levels and protects the environment. ■

New tyres

New tyres have to be "run in" since they do not offer optimal grip at first. You should take account of this fact for the first 500 kilometres and drive particularly carefully. ■

New brake pads

Allow for the fact that new brake pads do not achieve their full braking efficiency until approximately 200 kilometres. New brake pads must be first "run in" before they develop their optimal friction force. You can, however, compensate for this slightly reduced braking force by increasing the pressure on the brake pedal.

This guideline also applies to any new brake pads installed at a future date.

During the running-in period, you should avoid excessive stresses on the brakes. This includes, for example, violent braking, particularly from very high speeds, and also when crossing mountain passes. ■

Catalytic converter

Proper operation of the emission control system (catalytic converter) is of major significance for driving your vehicle in an environmentally conscious way.

Please refer to the following guidelines: 

- For vehicles with petrol engine only refuel with unleaded petrol ⇒ page 183, "Unleaded petrol".
- Never run the fuel tank completely empty.
- Do not switch off the ignition while you are driving the vehicle.
- Do not pour too much oil into the engine ⇒ page 190, "Replenishing engine oil".

If you drive your vehicle in a country in which unleaded petrol is not available, you must have the catalytic converter replaced later when driving the vehicle into a country in which use of a catalytic converter is mandatory.

WARNING

- In view of the high temperatures which may be produced in the catalytic converter, one should always park a vehicle in such a way that the catalytic converter cannot come into contact with easily flammable materials below the vehicle - a risk of fire!
- Never use additional underbody protection or corrosion-protection agents for the exhaust pipes, catalytic converters or heat shields. Such substances might ignite when driving - risk of fire!

Caution

- On vehicles fitted with a catalytic converter, never let the fuel tank run completely empty. An irregular fuel supply can result in poor ignition or misfiring. Unburnt fuel may get into the exhaust system and damage the catalytic converter.
- Filling the tank even only once with leaded petrol will result in the catalytic converter being destroyed.
- If you detect misfiring, a drop in performance or irregular engine running when driving, reduce your speed immediately and have the vehicle inspected by the nearest specialist garage. The symptoms described may be caused by a fault in the ignition system. Unburnt fuel may get into the exhaust system and damage the catalytic converter.

For the sake of the environment

Even if the exhaust system is operating properly, a sulphur-like exhaust odour may be produced under certain operating conditions of the engine. This depends on the sulphur content of the fuel. It is often sufficient to refuel with unleaded premium-grade petrol of a different brand or at a different filling station. ■

Driving in an economical and environmentally conscious manner

General

Your personal style of driving is a major factor.

Your fuel consumption, any pollution of the environmental and the wear-and-tear to the engine, brakes and tyres, depend essentially on three factors:

- your personal style of driving,
- the conditions under which your vehicle is operated,
- technical aspects.

You can easily improve your fuel economy by 10 - 15 percent by driving in an economical way with foresight. This section is intended to provide you with a number of tips on how to protect the environment and at the same time save money.

The fuel consumption can naturally also be influenced by factors which are beyond the driver's control. It is, for example, normal for the fuel consumption to increase in winter and under worsened conditions such as poor road conditions, towing a trailer, etc.

The technical requirements for low fuel usage and economic efficiency of the vehicle have already been built into the vehicle at the works. Special attention has been given to minimising negative effects on the environment. It is necessary to take note of the guidelines given in this chapter in order to make best use of these characteristics and to maintain their effectiveness.

The optimal engine speed should be obtained when accelerating, in order to avoid a high fuel consumption and resonance of the vehicle. ■

Looking ahead when driving

A vehicle's highest fuel consumption occurs it accelerates.

Avoid accelerating and braking unnecessarily. If you drive with foresight you will not need to brake so often and will also then not have to accelerate so much. Let your vehicle coast to a stop, for example, if this is possible, when you see that the next set of traffic lights is at red. ■

Shifting gears and saving energy

Shifting up early saves on fuel.

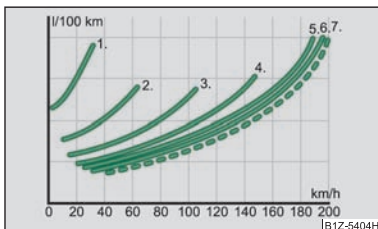

Fig. 155 Fuel consumption in litres/100 km. and speed in km/h.

Manual gearbox

- Drive no more than about one length of your vehicle in first gear.
- Shift up into the next higher gear at approx. 2 000 to 2 500 revs.

An effective way of achieving good fuel economy is to shift up **early**. You will consume more fuel if you drive at unnecessarily high revolutions in any given gear.

Automatic gearbox

- Depress the accelerator pedal **slowly**. Do not depress it beyond the kickdown position, however.

Only depress the accelerator pedal slowly if your vehicle is fitted with an automatic gearbox in order to automatically select an economic driving programme. You will achieve good fuel economy by shifting up early and shifting down late.

General

The ⇒ fig. 155 shows the ratio of fuel consumption to the speed of your vehicle in the relevant gears. The fuel economy is highest in 1st gear and lowest in 6th gear.



Note

Also use the information supplied by the multi-functional indicator ⇒ page 18. ■

Avoiding full throttle

Driving more slowly means saving fuel.

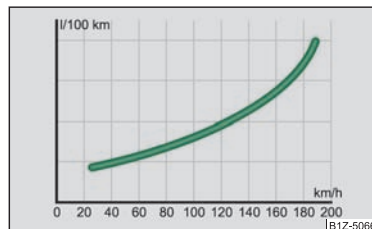

Fig. 156 Fuel consumption in litres/100 km. and speed in km/h.

Sensitive use of the accelerator will not only significantly reduce fuel consumption but also positively influence environmental pollution and wear of your vehicle.

You should avoid exploiting the top speed of your vehicle wherever possible. Fuel consumption, pollutant emissions and vehicle noises increase disproportionately at high speeds.

The ⇒ fig. 156 shows the ratio of fuel consumption to the speed of your vehicle. You will cut your fuel consumption by half if you only make use three-quarters of the possible top speed of your vehicle. ■

Reducing idling

Idling also costs fuel.

It is worthwhile switching off the engine in a traffic jam or when waiting at a level crossing or at traffic lights with a lengthy red phase. Even after just 30 - 40 seconds you will have saved more fuel than that is needed when you start the engine up again.

If an engine is only idling it takes much longer for it to reach its normal operating temperature. Wear-and-tear and pollutant emissions, though, are particularly high in the warming-up phase. This is why you should drive off right after starting the engine. Do avoid high engine revolutions at this time, however. ■

Regular servicing

A poorly tuned engine uses an unnecessarily high amount of fuel.

Having your vehicle serviced regularly at a specialist garage enables you to satisfy **one** of the requirements for economical motoring even before you set off on your journey. Keeping your vehicle properly serviced not only has a positive effect on the safety of your vehicle and maintaining its value, but also saves on **fuel**.

A poorly tuned engine can result in a fuel consumption which is 10 % higher than normal.

The foreseen maintenance work should be undertaken exactly according to the Service schedule by a specialist garage.

Also check the **oil level** after refueling. **Oil consumption** is dependent to a considerable extent on the load and speed of the engine. Oil consumption could be as high as 0.5 litres/1 000 km depending on your style of driving.

It is quite normal that a new engine has a higher oil consumption at first, and reaches its lowest level only after a certain running in time. It is therefore not possible to correctly assess the oil consumption of a new vehicle until after you have driven about 5 000 km.



For the sake of the environment

- You can achieve additional improvements in your fuel economy by using high-lubricity oils.
- Check the ground below your car at regular intervals to detect any leakages in good time. Please have your vehicle inspected by a specialist garage if you find any stains caused by oil or other fluids on the floor. ■

Avoid driving short distances

Short distances result in an above-average high fuel consumption.

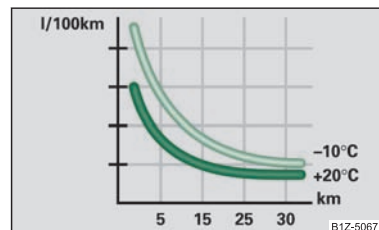

Fig. 157 Fuel consumption in litres/100 km at different temperatures

- Avoid driving a distance of no more than 4 km if the engine is cold.

The engine and catalytic converter must first have reached their optimal **operating temperature** in order to effectively reduce fuel consumption and pollutant emissions.

The cold engine vehicle consumes approx. 15 - 20 litres/100 km of fuel immediately after starting. Fuel consumption drops to 10 litres/100 km after just 1 kilometre. The engine reaches its operating temperature (outside temperature and engine dependent) only after about **4 to 10 kilometres** and the fuel consumption then stabilizes. You should therefore avoid driving short distances whenever possible.

An important factor in this connection is also the **ambient temperature**. The ⇒ fig. 157 shows the different fuel consumptions for the same distance, on the one hand at +20 °C and on the other hand at -10 °C. Your vehicle has a higher fuel consumption in winter than in summer. ■

Checking tyre inflation pressures

Tyres which are correctly inflated save fuel.

Always ensure that your tyres are inflated to the correct pressure at all times. The rolling resistance will be increased if the tyre filling pressure is too low. This will not only increase fuel consumption but also tyre wear and the driving behaviour will worsen.

Always check the inflation pressure of the tyres when **cold**.

Do not drive with **winter tyres** all year round for this costs about 10 % more fuel. Winter tyres are also louder. ■

No unnecessary ballast

Transporting ballast costs fuel.

The fact that every kilogram of extra **weight** increases your fuel consumption means that it is worth taking a look in the luggage compartment to avoid transporting any unnecessary ballast.

It is particularly in town traffic, when one is accelerating quite often, that the vehicle weight will have a significant effect upon the fuel consumption. A rule of thumb here is that an increase in weight of 100 kilograms will cause an increase in fuel consumption of about 1 litre/100 kilometres.

You may frequently also leave a **roof rack fitted** on just out of convenience, although you no longer need it. The increased aerodynamic drag of your vehicle causes it to use about 10 % more fuel than normal at a speed of 100 - 120 km/h, even when you are not carrying a load on the roof. ■

Saving electricity

Generating electricity costs fuel.

- Switch off electrical components as soon as you no longer need them.

When the engine is running, the alternator generates and supplies electrical power. If more electrical components of the electrical system are switched on, more fuel is needed to operate the alternator. ■

Keeping a log of your fuel consumption

If you really wish to keep a close check on your **fuel consumption**, it is best to enter the figures in a logbook. This does not take much time but is a very worthwhile exercise. It enables you to detect any change (positive and negative) at an early stage and to take any appropriate action.

If you find that your fuel consumption is too high, you should reflect on how, where and in what conditions you have driven the vehicle since you last refuelled. ■

Environmental compatibility

Environmental protection has played a major role in the design, selection of materials and manufacture of your new Škoda. Particular emphasis has been paid to a number of aspects, including:

Design measures

- Joints designed to be easily detached.
- Simplified disassembly due to the modular structure system.
- Improved purity of different classes of materials.
- Identification of all plastic parts in accordance with VDA Recommendation*260.
- Reduced fuel consumption and exhaust emission CO₂.
- Minimum fuel leakage during accidents.
- Reduced noise.

Choice of materials

- Extensive use of recyclable material.
- Air conditioning filled with CFC-free refrigerant.
- No cadmium.
- No asbestos.
- Reduction in the "vaporisation" of plastics.

Manufacture

- Solvent-free cavity protection.
- Solvent-free protection of the vehicle for transportation from the production plant to the customer.
- The use of solvent-free adhesives.
- No CFCs used in the production process.
- Without use of mercury.
- Use of water-soluble paints.

Trade-in and recycling of old cars

Škoda Auto meets the requirements of the brand and its products regarding environment and resource protection. All new Škoda vehicles can be utilized up to 95 % and always¹⁷⁾ be returned. In a lot of countries sufficient trade-in networks have been created, where you can trade-in your vehicle. After you trade-in your vehicle, you will receive a confirmation stating the recycling in accordance with environmental regulations.

Vehicles with special built-on types

Technical documents regarding changes carried out on the vehicle must be kept by the vehicle user, in order to hand over later to the old car user. This ensures the recycling in accordance with environmental regulations. ►

¹⁷⁾ Subject to fulfilment of the national legal requirements.

i Note

Detailed information about the trade-in and recycling of old cars is available from a Škoda Service Partner. ■

Motoring abroad

General

Other circumstances may exist abroad.

It is also possible, in certain countries, that the Škoda Service Partner network is limited or has not been established yet. This is the reason why obtaining certain spare parts may be somewhat complicated and specialist garage personnel may only be able to make limited repairs. Škoda Auto in the Czech Republic and its foreign importers are happy to provide information about technical aspects of the vehicle, required maintenance work and possibilities for getting repairs done. ■

Unleaded petrol

A vehicle fitted with a petrol engine must always be refuelled with unleaded petrol ⇒ page 168. The automobile associations can provide you with information regarding the locations of filling stations which offer unleaded petrol. ■

Headlight

The low beam of your headlights is set asymmetrically. It illuminates the side of the road on which you are driving to a greater extent. If you drive abroad on the other side of the road, you will dazzle oncoming traffic.

In order to prevent the dazzling of oncoming traffic, it is necessary that an adjustment of the headlights is carried out by a specialist garage.

The adaptation of the headlights with Xenon lights (applies only to vehicles which are designed for driving on the left and on the right) is performed in the menu **Settings Lights & Vision Travel mode** in the main menu of the Information display ⇒ page 22. ■

Avoiding damage to your vehicle

When driving on poor roads and lanes or when driving over kerbstones, steep ramps etc., you must pay particular attention to ensuring that any low-slung parts of the vehicle, such as spoiler and exhaust, do not touch the ground and get damaged.

This particularly applies to models with a lowered suspension (sport suspension) and also when your vehicle is fully laden. ■

Driving through bodies of water on roads

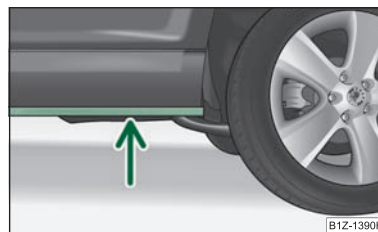



Fig. 158 Crossing bodies of water

In order to avoid damage to the vehicle when driving through bodies of water (e.g. flooded roads), observe the following:

- Determine the depth of the water when driving through bodies of water. The water can reach at the maximum the web on the lower sill of the vehicle ⇒ fig. 158.
- Drive no more than at walking speed. At a higher speed, a water wave can form in front of the vehicle which can cause water to penetrate into the air induction system of the engine or into other parts of the vehicle.
- Never let the vehicle stand in the water, never drive backwards and do not switch off the engine.

⚠ WARNING

- Driving through water, mud, sludge etc. can reduce the braking power and extend the braking distance - risk of accident!
- Avoid sudden and severe braking manoeuvres immediately after driving through bodies of water.
- After driving through bodies of water, the brakes must be cleaned and dried as soon as possible by intermittent braking. Only apply the brakes for the

 **WARNING (continued)**

purpose of drying and cleaning the brake discs if the traffic conditions permit this. Do not place any other road users in jeopardy.

 **Caution**

- When driving through bodies of water, parts of the vehicle such as the engine, gearbox, catalytic converter, chassis or electrics can be severely damaged.
- Oncoming vehicles can generate water waves which can exceed the permissible water level for your vehicle.
- Potholes, mud or rocks can be hidden under the water making it difficult or impossible to drive through the body of water.
- Do not drive through salt water. The salt can lead to corrosion. Immediately rinse all the parts of the vehicle, which came into contact with the salt water, with fresh water.

 **Note**

After driving through a body of water, we recommend that the vehicle is checked by a specialist garage. ■

Towing a trailer

Towing a trailer

Technical requirements

Your vehicle is designed primarily for transporting persons and luggage. It can, however, also be used for towing a trailer - provided certain technical equipment is fitted.

If your vehicle has been **factory-fitted** with a towing device or has a towing device from Škoda Original Accessories, then the towing device satisfies all technical and legal requirements.

Your vehicle is fitted with a 13-pin power socket for the electrical connection between the vehicle and trailer. If the trailer which you wish to tow has a **7-pin connector**, you can use a suitable adapter from Škoda original accessories.

This work must be carried out in accordance with the manufacturer's specifications if a towing device is retrofitted.

Authorised Škoda Service Partners can provide detailed information about retrofitting a towing device and for any necessary modifications to the cooling system.

WARNING

We recommend that you have the towing device from Škoda original accessories installed by an authorised Škoda Service Partner. He is familiar with all the relevant details relating to retrofitting such equipment. There is a risk of an accident if the towing device is not properly fitted! ■

General Maintenance

Trailer load

The permissible trailer load must on no account be exceeded.

You can negotiate appropriately steeper inclines and descents if you do not make full use of the permissible trailer load.

The trailer loads specified only apply for **altitudes** up to 1000 metres above mean sea level. The fact that the engine power output drops with increasing height due to a lowering of air pressure and thus the ability to climb, means that the towed weight must be reduced by 10 % for every further increase of 1 000 metres in height above sea level. The towed weight is the weight of the (laden) vehicle and the

(laden) trailer together. One should take this into account before driving up to higher altitudes.

The trailer and drawbar load information on the type plate of the towing device are merely test data for the towing device. The data relating to your vehicle, which is often less than this test data, can be found in your vehicle registration documents.

Distribution of the load

Distribute the load in the trailer in such a way that any heavy items are located as close as possible to the axle. Secure the items to prevent them slipping.

Tyre pressure

Correct the tyre inflation pressure on your vehicle for that of "fully laden" ⇒ page 199. The inflation pressure of the tyres fitted to the trailer adjust in accordance with the manufacturer's recommendation.

Exterior mirrors

You have to have additional exterior mirrors fitted if you are not able to see the traffic behind the trailer with the standard rear-view mirrors. Both exterior mirrors should be attached to folding arms. Adjust the mirrors so that they provide you with an adequate field of view to the rear.

Headlights

Before starting off with a hitched trailer, also check the setting of the headlights. After the setting as necessary with the aid of the headlight beam adjuster ⇒ page 53.

Detachable ball head

The ball rod is detachable on vehicles with towing device and suppliable from Škoda original accessories. It is stowed together with separate fitting instructions in the spare wheel well in the luggage compartment of the vehicle.

Note

- We recommend that you also have your vehicle inspected between service intervals if you tow a trailer frequently.
- The handbrake on the towing vehicle must be put on when coupling and decoupling the trailer. ■

Driving Tips

- Do not, as far as possible, drive with your vehicle unladen and the trailer laden.
- Do not make full use of the legal maximum speeds. This applies in particular to downhill sections.
- Apply the brakes in good time.
- Keep a check on the coolant temperature gauge if the outside temperature is high.

Distribution of weight

The distribution of the weight is very poor if your vehicle is unladen and the trailer is laden. Maintain a particularly low speed if you cannot avoid driving with this combination.

Driving speed

Do not drive faster than 80 km/hour for safety reasons. This also applies for countries in which higher speeds are allowed.

The fact that the driving stability of the vehicle + trailer combination reduces with increasing speed means that the legally allowed speed should not be used when there are unfavourable road, weather or wind conditions, particularly near accident black spots.

You must always reduce your speed immediately as soon as you detect even just the **slightest swaying** of the trailer. On no account attempt to stop the trailer from "swaying" by accelerating.

Apply the brakes in good time! If the trailer is fitted with a **trailer brake**, apply the brakes gently at first and then brake firmly. This will avoid brake jolts resulting from the trailer wheels locking. Shift down gears in good time before negotiating a downhill section to allow the engine to also act as a brake.

Engine overheating

Please keep a check on the coolant temperature gauge if you have to negotiate a lengthy slope in a low gear at a high engine speed when the outside temperature is very high ⇒ page 16, "Coolant temperature gauge".

If the needle of the coolant temperature gauge moves into the right-hand area or even the red area of the scale, reduce your speed immediately. Stop and switch off the engine if the warning light  in the instrument cluster begins flashing. Wait a few minutes and check the level of coolant in the coolant expansion bottle ⇒ page 192, "Inspecting the coolant level".

Please refer to the following guidelines ⇒ page 30, "Coolant temperature/ Coolant quantity .

The coolant temperature can be reduced by switching on the heating.

Any increase in the cooling effect of the coolant fan through shifting down a gear and increasing the engine speed is not possible since the fan speed is independent of the engine speed. One should also not drop a gear for this reason when towing a trailer as long as the engine can manage the slope without any drop in speed. ■

General Maintenance

Taking care of your vehicle and cleaning the vehicle

General

Proper care retains the commercial value of your vehicle.

Regular and proper care retains **the value** of your vehicle. It may also be one of the requirements for the acceptance of warranty claims relating to corrosion damage and paint defects on the bodywork.

We recommend you use care products from Škoda Original accessories which are available from authorised Škoda Service Partners. Please follow the instructions for use on the package.

WARNING

- Care products may be harmful to your health if not used according to the instructions.
- Always store care products in a safe place, out of the reach of children - risk of poisoning!



For the sake of the environment

- Always select environmentally-friendly products when purchasing vehicle care products.
- Do not dispose of the packages with residues of care products in domestic waste. ■

Care of the exterior of vehicle

Washing the vehicle

Frequent washing protects your vehicle.

The best protection for your vehicle against harmful environmental influences is **frequent** washing and wax treatment. How often you should wash your vehicle depends on a wide range of factors, such as:

- Frequency of use,
- The parking situation (garage, below trees etc.),
- Season of the year,
- Weather conditions,
- Environmental influences.

The longer insect residues, bird droppings, tree sap, road and industrial dust, tar, soot particles, road salt and other aggressive deposits remain adhering to the paintwork of your vehicle, the more detrimental their destructive effect can be. High temperatures, such as those caused by intensive sun's rays, accentuate this caustic effect.

It may therefore be necessary, in certain circumstances, to wash the car **once a week**. It may also be sufficient, however, to wash the car **once a month** followed by appropriate wax treatment.

It is essential to also thoroughly wash the **underside of your vehicle** at the end of the winter road salting and gritting period.

WARNING

When washing your vehicle in the winter: Water and ice in the brake system can affect the braking efficiency - risk of accident! ■

Automatic vehicle wash systems

The paintwork of the vehicle is sufficiently resistant that the vehicle can be washed normally in automatic vehicle wash plants without any problem. The actual stress to which the paintwork is subjected, however, depends greatly on the design of the vehicle wash system, the filtering of the water and the type of washing and care products used. If the paintwork of your vehicle appears mat after being washed or even has scratches, point this out to the operator of the vehicle wash plant. Use a different vehicle wash plant, if necessary.

There are no particular points to note before washing your vehicle in an automatic vehicle wash system other than the usual precautionary measures (closing the windows including the sliding/tilting roof, removing the external antenna, etc.). ▶

If you have any particular attached parts fitted to your car - such as spoiler, roof rack system, two-way radio aerial - it is best to first of all consult the operator of the car wash plant.

It is important to degrease the lips of the windscreen wiper rubbers after passing through the automatic vehicle wash system. ■

Washing vehicle by hand

It is important to first soften the dirt with plenty of water and rinse it off as thoroughly as possible before washing your vehicle by hand.

One should then clean the vehicle using a soft **washing sponge**, **washing glove** or a **washing brush** and only slight pressure. Work from the top to the bottom - beginning with the roof. Only place slight pressure on the vehicle paintwork during cleaning. Only use a **car shampoo** for stubborn dirt.

Wash out the sponge or washing glove thoroughly at short intervals.

Clean wheels, door sills and similar parts last. Use a second sponge for such areas.

Rinse off the vehicle well after giving it a wash and dry it off using a chamois leather.

WARNING

- The ignition should always be switched off when you wash your vehicle - risk of accident!
- Protect your hands and arms from sharp-edged metal parts when you are cleaning the underfloor, the inside of the wheel housings or the wheel trims - risk of cuts.

Caution

- Do not wash your vehicle in bright sunlight - risk of paint damage.
- Ensure that the jet of water is not aimed directly at the locking cylinders or at the door and panel joints if you spray your vehicle in winter down with a hose - risk of freezing.
- Do not use any insect sponges, rough kitchen sponges or similar cleaning products - risk of damage to the surface of paintwork.

For the sake of the environment

Only wash your vehicle at washing bays specifically reserved for this purpose. This ensures that no water which may be contaminated by oil flows into the sewage

system. It is not even permitted to wash your vehicle in certain areas except at such specific washing bays. ■

Washing with a high-pressure cleaner

When you wash your vehicle with a high-pressure cleaner, it is essential to comply with the instructions for use of the cleaning equipment. This applies in particular to the **pressure** used and to the **spraying distance**. Maintain a sufficiently large distance to soft materials such as rubber hoses or insulation material.

On no account use **circular spray nozzles** or so-called **dirt cutters**!

WARNING

It is particularly important that you do not clean tyres with circular spray jets. Visible but also invisible damage to tyres may occur even at a relatively large spraying distance and if sprayed only for a short time - risk of accident!

Caution

The water containing wax must be no hotter than 60 °C, otherwise the vehicle can be damaged. ■

Wax treatment

Good wax treatment is an effective way of protecting the paintwork from harmful environmental influences and minor mechanical damage.

The vehicle must be treated with a high-quality hard wax polish at the latest, when no more drops form on the clean paintwork.

A new layer of a high-quality hard wax polish can be applied to the clean bodywork after it has dried thoroughly. Even if you use a wax preserver regularly we still recommend that you treat the paintwork of the vehicle at least twice a year with hard wax.

Caution

Never apply wax to the windows. ■

Polishing

Polishing is only necessary if the paintwork of your vehicle has become unattractive and if it is no longer possible to achieve a gloss with wax preservers.

You must treat the paintwork with a wax preserver if the polish you use does not contain any preserving elements → page 178.

We recommend using a preservative from Škoda genuine accessories offered by your Škoda dealer.

⚠ Caution

- You must not treat mat painted parts or plastic with polishing products or hard wax.
- Do not polish the paintwork of the vehicle in a dusty environment, otherwise the paintwork can be scratched. ■

Chrome parts

First clean the chrome parts with a damp cloth and then polish them with a soft, dry cloth. If this method does not completely clean chrome parts, use a specific chrome care product.

⚠ Caution

Do not polish the chrome parts in a dusty environment, otherwise they can be scratched. ■

Paint damage

Slight damage to paintwork such as scratches, scuffs or traces of chip damage must be touched up immediately with paint (Škoda painting pen) **before** any corrosion can result. You can of course have this work carried out by authorised Škoda Service Partners.

The authorised Škoda Service Partners have a range of matching **touch-up pens** or **spray cans** available in the colour of your vehicle.

The paint number of the original paintwork of your vehicle is indicated on the vehicle data sticker → page 228.

Any corrosion which has already have formed must be removed thoroughly. Apply a **corrosion protection primer** and then the paint to the affected point. You can of course have this work carried out by authorised Škoda Service Partners. ■

Plastic parts

External plastic parts are cleaned by normal washing. Plastic parts and synthetic leather can also be treated with **special solvent-free plastic cleaning agents** if a damp cloth is not sufficient. Paint care products are not suitable for plastic parts.

⚠ Caution

Solvent-free cleaners attack the material and can damage it. ■

Windows

Only use a plastic ice scraper for removing snow and ice from the windows and mirrors. You should not move the ice scraper forward and backward but in one direction on the window which you are cleaning in order to avoid any damage to the surface of the glass.

You can best remove residues of rubber, oil, grease, wax or silicone by using a special window cleaner or a special silicone remover.

You should also clean the windows regularly from the inside.

Do not use window leathers which you have used to polish the vehicle body to dry off the windows. Residues of preservatives in the window leather can dirty the window and reduce visibility.

Do not affix any stickers over the inside of the rear window to avoid damage to the **heating elements of the rear window heater**.

⚠ Caution

- Never remove snow or ice from the glass parts with warm or hot water - risk of formation of cracks in the glass!
- When removing snow or ice from the windows and mirror lenses make sure not to damage the paintwork of the vehicle. ■

The headlight lenses

Please do not use any aggressive cleaning or chemical solvent products for cleaning the front headlights - risk of damage to the plastic lenses. **Please use soap and clean warm water.** ►

Caution

Never wipe the headlights dry and do not use any sharp objects for cleaning the plastic lenses, this may result in damage to the protective paintwork and consequently in formation of cracks on the headlight lenses, e.g. through effect of chemical products. ■

Door and window seals

The rubber seals on the doors, boot lid, bonnet, roof window and windows remain supple and last longer if you treat them from time to time with a rubber care product (e.g. with a spray with silicone-free oil). You also avoid premature wear of the seals and prevent leakages in this way. It is also easier to open the doors. Rubber seals which are well cared for also do not stick together in cold winter weather. ■

Locking cylinder

Use specific products for de-icing locking cylinders.

Note

When washing your vehicle, ensure that as little water as possible gets into the locking cylinders. ■

Wheels

Steel wheels

You should also thoroughly wash the wheels and wheel trims when giving your vehicle its regular wash. This prevents any brake dust, dirt and road salt from sticking to the wheel hubs. You can remove stubborn brake abrasion adhering to the wheels with an industrial cleaner. Touch up any damage to the paintwork on the wheels before rust is able to form.

Light alloy wheels

Regular care of light alloy wheels is necessary in order to retain their decorative appearance over long periods. It is particularly important to remove regularly any road salt and brake abrasion from light alloy wheels, otherwise the light metal will suffer. Wash thoroughly and then treat the wheels with a protective product for light alloy wheels which does not contain any acidic components. We recommend to apply a hard wax layer onto the wheel hubs every three months. You must not use any products which cause abrasion when treating the wheel hubs. Any damage to the paint layer on the wheel hubs must be touched up immediately.

WARNING

One should remember when cleaning the wheels that moisture, ice and road salt may adversely affect braking efficiency - risk of an accident!

Note

Severe layers of dirt on the wheels can also result in wheel imbalance. This may show itself in the form of a wheel vibration which is transmitted to the steering wheel which, in certain circumstances, can cause premature wear of the steering. This means it is necessary to remove the dirt. ■

Underbody protection

The underside of your vehicle is protected for life against chemical and mechanical influences.

One cannot, however, completely rule out damage to the **protective layer** when driving so we recommend that you inspect the protective layer on the underside of your vehicle and on the chassis at certain intervals - this is best done at the beginning and end of the winter - and to touch up any damaged areas.

The authorised Škoda Service Partners have suitable **spray products** available as well as the necessary equipment and are familiar with the instructions for use. Therefore, we recommend you have such touch-up work or additional corrosion protection measures carried out by an authorised Škoda Service Partner.

WARNING

Never use additional underbody protection or corrosion-protection agents for the exhaust pipes, catalytic converters, diesel particle filter or heat shields. When the engine reaches its operating temperature, these substances might ignite - risk of fire! ■

Protection of hollow spaces

All the cavities of your vehicle which are at risk from corrosion are protected for life by a layer of **protective wax** applied in the factory.

This wax protection does not require to be inspected or re-treated. Please remove any small amount of wax which flows out of the cavities at high temperatures with a plastic scraper and clean the spot using petroleum cleaner. ►

 **WARNING**

Safety and environmental protection regulations should be observed when using petroleum cleaner to remove wax - a risk of fire! ■

Care of the interior of vehicle

Plastic parts, artificial leather and cloths

You can clean plastic parts and artificial leather with a moist cloth. You should only treat such parts with special **solvent-free plastic cleaning and care products** if it does prove to be adequate.

Upholstery cloth and cloth trim on the doors, luggage compartment cover, headliner etc. are best treated with special cleaning products, using if necessary a **dry foam** and a soft sponge or brush.

 **Caution**

Solvent-free cleaners attack the material and can damage it. ■

Fabric covers of electrically heated seats

Do **not clean** the seat covers moist as this may result in damage to the seat heating system.

Clean such covers using special agents, for example dry foam. ■

Natural leather

Natural leather requires quite particular care and attention.

Leather should be treated from time to time according to the following guidelines depending on how much it is used.

Normal cleaning

- Clean soiled areas of the leather with slightly moistened cotton or woollen cloth.

Severe soiling

- Clean severely soiled areas with a cloth dipped in a mild soapy solution (2 spoonfuls of natural soap to 1 litre of water).
- Ensure that the leather is not soaked through at any point and that no water gets into the stitching of the seams.
- Dry off the leather with a soft, dry cloth.

Removing stains

- Remove fresh stains which are **water-based** (e.g. coffee, tea, juices, blood etc.) with an absorbent cloth or household paper or use the cleaner from the care set for a stain which has already dried in.
- Remove fresh stains on a **fat base** (e.g. butter, mayonnaise, chocolate etc.) with an absorbent cloth or household cleaning paper or with the cleaner from the care set if the stain has not yet penetrated into the surface.
- Use a grease dissolver for **grease stains which have dried in**.
- Eliminate **special stains** (e.g. ball-point pens, felt pen, nail varnish, dispersion paint, shoe cream etc.) with a special stain remover suitable for leather.

Leather care

- Treat the leather every six months with a special leather care product.
- Apply only a small amount of the care product.
- Dry the leather off with a soft cloth

 **Caution**

- You must on no account treat the leather with solvents (e.g. gasoline, turpentine), floor wax, shoe cream or such like.
- Avoid leaving your vehicle for lengthy periods in bright sunlight in order to avoid bleaching the leather. If you leave your vehicle parked in the open for lengthy periods, protect the leather from the direct rays of the sun by covering it over.
- Sharp-edged objects on items of clothing such as zip fasteners, rivets, sharp-edged belts may leave permanent scratches or signs of rubbing on the surface.

 **Note**

- Use a care cream with light blocker and impregnation effect regularly and each time after cleaning the leather. The cream nourishes the leather, allows it to ►

breathe and keeps it supple and also provides moisture. It also creates surface protection.

- Clean the leather every 2 to 3 months, remove fresh soiling each time this occurs.
- Remove fresh stains such as those from ball-point pens, ink, lipstick, shoe cream etc., as quickly as possible.
- Care also for the leather dye. Refreshen areas which have lost their colour with a special coloured leather cream as required.
- The leather is a natural material with specific properties. During the use of the vehicle, minor optical changes can occur on the leather parts of the covers (e. g wrinkles or creases as a result of the stress of the covers). ■

Seat belts

- Keep the seat belts clean!
- Wash seat belts which have become soiled using a mild soapy solution.
- Inspect the seat belts regularly to ensure they are in good condition.

Belt webbing which has become severely soiled may prevent the inertia reel from reeling up the belt properly.



WARNING

- The seat belts must not be removed for cleaning.
- Never clean the seat belts chemically as dry cleaning may destroy the fabric. The seat belts must also not be allowed to come into contact with corrosive liquids (such as acids etc.).
- Seat belts which have damage to the webbing, the connections, the inertia reel or the lock should be replaced by a specialist garage.
- Inertia reel belts must be completely dried before being reeled up. ■

Fuel

Petrol

Unleaded petrol

Your vehicle can only be operated with **unleaded petrol**, which complies with the standard **EN 228** (In Germany: standard **DIN 51626 - 1** or **E10** for unleaded fuel with octane rating **95 RON** and **91 RON** or **DIN 51626 - 2** or **E5** for unleaded fuel with octane rating **98**). On the inside of the fuel filler flap, you will find the information regarding the RON required by your engine ⇒ page 185, fig. 160 - right.

Prescribed fuel - unleaded petrol 95/91 RON

Use unleaded fuel with the octane rating **95 RON**. You can also use unleaded petrol **91 RON**, but this leads to a slight loss in performance.

If, in case of necessity, the vehicle must be refuelled with petrol of a lower octane number than the one prescribed, you must continue driving at medium engine speeds and low engine load. Driving at high engine revs or a high engine load can severely damage the engine! Refuel as soon as possible with petrol of the prescribed octane number.

Prescribed fuel - unleaded petrol min. 95 RON

Use unleaded fuel with the octane rating **95 RON**.

In case of necessity, you can refuel with petrol with the octane rating **91 RON** if petrol with the octane rating **95 RON** is not available. You must continue driving at medium engine speeds and minimum engine load. Driving at high engine revs or a high engine load can severely damage the engine! Refuel as soon as possible with petrol of the prescribed octane number.

Even in case of necessity, you must not use petrol of a lower octane number than **91 RON**, otherwise the engine can be severely damaged!

You can find further information on refuelling ⇒ page 185, "Refuelling".

Unleaded petrol with higher octane number

You can make unlimited use of unleaded petrol which has a higher octane number than the one prescribed.

On vehicles with prescribed unleaded petrol **95/91 RON**, the use of petrol with a higher octane number than **95 RON** does not result in a noticeable power increase or a lower fuel consumption.

On vehicles with prescribed unleaded petrol **min. 95 RON**, the use of petrol with a higher octane number than **95 RON** does not result in a power increase or a lower fuel consumption.

Prescribed fuel - unleaded petrol 98/95 RON

Use unleaded fuel with the octane rating **98 RON**. You can also use unleaded petrol **95 RON**, but this leads to a slight loss in performance.

In case of necessity, you can refuel with petrol with the octane rating **91 RON** if unleaded fuel with octane rating **98 RON** or **95 RON** is not available. You must continue driving at medium engine speeds and minimum engine load. Driving at high engine revs or a high engine load can severely damage the engine! Refuel as soon as possible with petrol of the prescribed octane number.

Even in case of necessity, you must not use petrol of a lower octane number than **91 RON**, otherwise the engine can be severely damaged!

Caution

- All Škoda vehicles with petrol engines are equipped with a catalytic converter and must be only driven with unleaded petrol. Filling the tank even only once with leaded petrol will result in the catalytic converter being destroyed!
- Only use unleaded fuel that complies with the standard **EN 228** (In Germany: standard **DIN 51626 - 1** or **E10** for unleaded fuel with octane rating **95 RON** and **91 RON** or **DIN 51626 - 2** or **E5** for unleaded fuel with octane rating **98**).
- If you use petrol with a lower octane number than the one prescribed, the engine can be severely damaged! ■

Biofuel Ethanol E85

Ethanol E85

Only valid for vehicles with 1.6/75 kW MultiFuel engine.

Biofuel Ethanol E85 consists of 85 % bioethanol and 15 % unleaded petrol complying with the standard (DIN) EN 228.

Biofuel Ethanol E85 in accordance with the standard (DIN) EN 228 can be mixed in any desired ratio with unleaded petrol. ►

Drive the vehicle for at least 5 minutes without interruption, if biofuel Ethanol E85 has been refuelled, so that the engine control unit can determine the share of the biofuel in the fuel. During this period do not drive at top speed of your vehicle or high engine speeds and not at full throttle. During this process decrease the idling speed.

WARNING

Pay attention to any legal requirements if you do carry a spare canister in the vehicle. We do not recommend carrying any fuel canisters in your vehicle for safety reasons. The canister can be damaged in the event of an accident and fuel may leak out.

Caution

- Even inadvertently filling the fuel tank with another biofuel such as Ethanol E85 can result in damage to the fuel system.
- If you park the car for a lengthy period, fill with petrol complying with (DIN) EN 228, because Ethanol E85 can contain low quantities of impurities, which can lead to corrosion.

For the sake of the environment

If you use Ethanol E85, the CO₂ emission of your vehicle is lowered up to 5 %.

Note

- When operating with Ethanol E85, the fuel consumption increases by approx 33 %, as a lower quantity of energy is contained in the bioethanol than in unleaded petrol.
- Biofuel Ethanol E85 contains only a low quantity of additives in contrast to unleaded petrol. Therefore we recommend to fill up the tank with unleaded petrol complying with EN 228 every 15 000 km (e.g. before the oil change) and run it empty, so that the engine remains clean. Make sure not to use the whole content of the tank ⇒ page 185, "Refuelling".
- The interval of 15 000 km applies for the oil change. ■

Operation in winter



Fig. 159 MultiFuel - power socket

If you use biofuel Ethanol E85 at very low temperatures, it is necessary to preheat the engine before an engine start.

The power socket for the engine preheating is located in the front bumper next to the fog light ⇒ fig. 159.

The outside temperature	Duration of engine preheating
lower than -10 °C	we recommend up to 1 hour
lower than -15 °C	at least 1 hour
lower than -25 °C	at least 2 hours.

If an engine preheating is not possible at outside temperatures lower than -10 °C, the share of unleaded petrol complying with EN 228 must be as high as possible. Thus the cold start property of the engine is clearly improved.

If there is biofuel Ethanol E85 in the tank and the engine is not preheated, it can lead at temperatures below -15 °C to very poor or no starting of the engine.

For the sake of the environment

The use of engine preheating at temperatures below -10 °C has a positive effect on the fuel consumption and thus on the environment.

Note

An extension cable used for connecting to the electrical network is located in the luggage compartment. ■

Diesel

Diesel fuel

Your vehicle can only be operated with **diesel fuel**, which complies with the standard **EN 590** (standard **DIN 51628** in Germany, standard **ÖNORM C 1590** in Austria, **GOST R 52368-2005/EN 590:2004** in Russia).

Fuel additives

You must not use fuel additives, so-called "flow improvers" (petrol and similar products) in diesel fuel.

You can find information on refuelling ⇒ page 185, "Refuelling".

⚠ Caution

- Your vehicle can only be operated with diesel fuel, which complies with the standard **EN 590** (standard **DIN 51628** in Germany, standard **ÖNORM C 1590** in Austria, **GOST R 52368-2005/EN 590:2004** in Russia). Filling the tank even only once with diesel fuel which does not comply with the standard, can result in damage to the engine parts, the lubrication system, the fuel and exhaust system.
- If by mistake you have refuelled with a different fuel other than the diesel fuel which complies to the above mentioned standards (e. g. petrol), do not start the engine or switch on the ignition! Severe damage is possible! Contact a specialist garage and have the fuel system of the engine cleaned.
- Water which has collected in the fuel filter can result in engine problems.
- Your vehicle is not adapted for use of biofuel (RME), therefore this fuel must not be refuelled and driven. The use of biofuel (RME) can lead to damage to the engine or the fuel system. ■

Operation in winter

Winter-grade diesel fuel

A different grade of diesel fuel is available at filling stations in winter than during the summer. Using "summer-grade diesel fuel" at temperatures below 0 °C can result in operational problems because the diesel becomes viscous as a result of paraffin separation.

It is therefore the case that the standard **EN 590** (standard **DIN 51628** in Germany, standard **ÖNORM C 1590** in Austria, **GOST R 52368-2005/EN 590:2004** in Russia) is the diesel fuel class prescribed for certain periods of the year which can also be

purchased at the corresponding time during the year. "Winter-grade diesel fuel" will still operate properly even at a temperature of -20 °C.

It is often the case in countries with different climatic conditions that diesel fuels available have a different temperature characteristic. The authorised Škoda Service Partners and filling stations in the country concerned will be able to provide you with information regarding the diesel fuels available.

Prewarming fuel

The vehicle is fitted with a fuel filter prewarming system. This secures operation of a vehicle using diesel fuel down to an environmental temperature of -25 °C.

⚠ Caution

It is not permitted to add the various fuel additives on the market, including petrol, to diesel fuel in order to improve its flow properties. ■

Refuelling

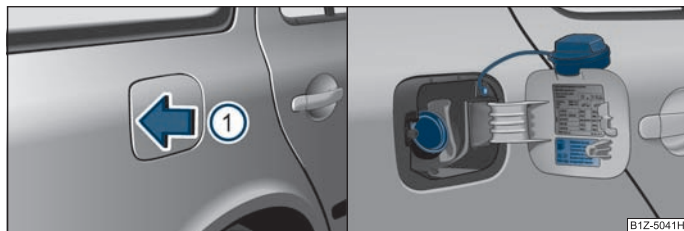

Fig. 160 Right rear side of the vehicle: Open fuel filler flap/fuel filler flap with cap unscrewed

The filler flap is automatically unlocked or locked with the central locking.

Opening the fuel filler cap

- Press in the middle of the left area of the fuel filler flap in direction of arrow ① ⇒ fig. 160.
- Hold the fuel filler cap on the fuel filler tube with one hand and unlock it by turning the vehicle key to the left (only valid for vehicles which do not have automatic unlocking of the fuel filler flap). ▶

- Unscrew the fuel filler cap anti-clockwise and place the fuel filler cap from above on the fuel filler flap ⇒ page 185, fig. 160 - right.

Closing fuel filler cap

- Screw on the cap by turning it to the right until it is heard to lock.
- Hold the fuel filler cap on the fuel filler tube with one hand and lock it by turning the vehicle key to the right (only valid for vehicles which do not have automatic locking of the fuel filler flap).
- Close the fuel filler flap until it locks.

The correct grade of fuel for your vehicle as well as the tyre size and inflation pressures are stated on a sticker affixed to the inside of the fuel filler flap. Further information on fuel ⇒ page 183.

The fuel tank has a capacity of about 55 litres or 60 litres ¹⁸⁾.



WARNING

Pay attention to any legal requirements if you do carry a spare canister in the vehicle. We do not recommend carrying any fuel canisters in your vehicle for safety reasons. The canister can be damaged in the event of an accident and fuel may leak out.



Caution

- Before refuelling it is necessary to switch off the auxiliary heating system (auxiliary heating and ventilation).
- Remove any fuel which has spilled onto the paintwork of your vehicle immediately - risk of paint damage!
- On vehicles fitted with a catalytic converter, never let the fuel tank run completely empty. An irregular supply of fuel to the engine can result in misfiring and unburnt fuel may get into the exhaust system, which may result in overheating and damage to the catalytic converter.
- The fuel tank is full just as soon as the pump nozzle switches off for the first time, provided the nozzle has been operated properly. Do not continue refuelling - otherwise the expansion volume is filled up. ■

¹⁸⁾ Valid for Octavia Estate car 4x4 and Octavia Scout.

Inspecting and Replenishing

Engine compartment

Bonnet remote release

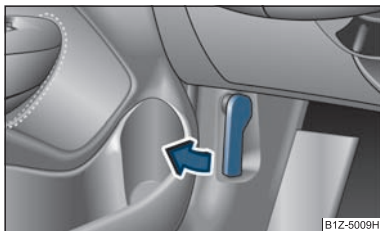

Fig. 161 Bonnet release lever

Bonnet remote release

- Pull the unlocking lever below the dash panel on the driver's side ⇒ fig. 161.

The bonnet jumps out of its lock as a result of the spring force. A locking lever appears at the same time in the radiator grille. ■

Opening and closing the bonnet.



Fig. 162 Radiator grille: Locking lever/securing the bonnet with the bonnet support

Opening the bonnet

- Unlock the bonnet ⇒ fig. 161.
- Ensure that the arms of the windscreen wipers are correctly in place against the windscreen **before opening** the bonnet otherwise damage could occur to the paintwork.
- Pulling on the locking lever in direction of arrow ① ⇒ fig. 162 will unlock the bonnet.
- Grip with the hand under the radiator grille and lift up the bonnet.
- Take the bonnet support out of its holder and set it in the opening ② designed for it.

Closing the bonnet

- Lift the bonnet slightly and unhook the bonnet support. Press the bonnet support into the holder designed to hold it.
- Allow the bonnet to drop from a height of about 20 cm into the lock - **bonnet do not press down on it!**
- Check whether the bonnet is properly closed.

WARNING

- Never open the bonnet if you see that steam or coolant is flowing out of the engine compartment - risk of scalding! Wait long enough until the steam or coolant has stopped escaping.
- For safety reasons, the bonnet must always be properly closed when driving. One should therefore check that the lock has in fact engaged properly after closing the bonnet.
- Stop your vehicle immediately while driving if you notice that the lock is not properly engaged and close the bonnet properly - risk of an accident!

Caution

Never open the bonnet using the locking lever - danger of causing damage. ■

Working in the engine compartment

Particular care is required when carrying out any work in the engine compartment!

There is a risk of injuries, scalding, accidents and fire when working in the engine compartment, e.g. inspecting and replenishing oil and other fluids. For this reason, it is essential to comply with the warning instructions stated below and with the general applicable rules of safety. The engine compartment of your car is a hazardous area ⇒ .

WARNING

- Never open the bonnet if you see that steam or coolant is flowing out of the engine compartment - risk of scalding! Wait long enough until the steam or coolant has stopped escaping.
- Switch off the engine and pull out the ignition key.
- Apply the handbrake firmly.
- If your vehicle is fitted with a manual gearbox, move the gearshift lever into Neutral, or if it is fitted with automatic gearbox, move the selector lever into position P.
- Allow the engine to cool down.
- Keep children clear of the engine compartment.
- Do not touch any hot engine parts - risk of burns!
- Never spill oil and other fluids over the hot engine. Such fluids (e.g. the anti-freeze contained in the coolant) may ignite!
- Avoid short circuits in the electrical system - particularly on the battery.
- Never place your hand into the radiator fan as long as the engine is still warm. The fan might suddenly start running!
- Never open the cap of the coolant expansion bottle as long as the engine is still warm. The cooling system is pressurized!
- Cover over the cap of the coolant expansion reservoir with a large cloth when opening it as protection for your face, hands and arms from hot steam or hot coolant.
- Do not let objects, such as e.g. cleaning cloth or tools lie in the engine compartment.
- If you wish to work under the vehicle, you must secure the vehicle from rolling away and support it with suitable supporting blocks: the car jack is not sufficient for this - risk of injury!

WARNING (continued)

- In cases where it be necessary to carry out inspection work when the engine is running there is an additional risk from rotating parts (e.g. the V-ribbed belt, alternator, radiator fan) and from the high-voltage ignition system. Please observe in addition the following:
 - Never touch the electrical cables of the ignition system.
 - Absolutely avoid any jewellery, loose items of clothing or long hair from getting into the rotating parts of the engine - Hazard! Therefore remove any jewellery beforehand, tie up your hair and wear tight fitting clothing.
- Please also comply with the warning instructions stated below when carrying out any essential work on the fuel system or on the electrical system.
 - Always separate the car battery from the electrical system.
 - Do not smoke.
 - Never carry out any work close to naked flames.
 - Always keep a working fire extinguisher at hand.

Caution

When replenishing fluids in the engine, always ensure that the fluids are on no account mixed up. This may result in major operating problems and also vehicle damage! ■

Overview of the engine compartment

The main inspection points.

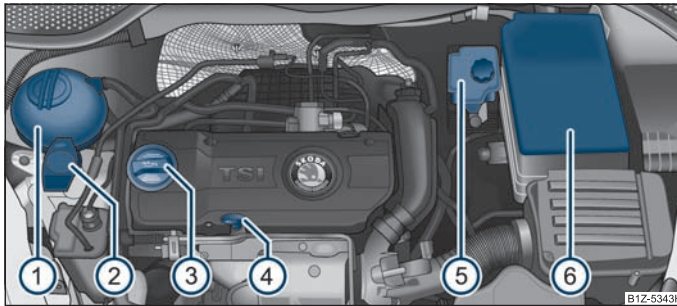

Fig. 163 Petrol engine 1.8 ltr./118 kW TSI

①	Coolant expansion bottle	192
②	Windshield washer fluid reservoir	197
③	Engine oil filler opening	190
④	Engine oil dipstick	189
⑤	Brake fluid reservoir	193
⑥	Battery (below a cover)	194

Note

The location of the inspection points in the engine compartment of petrol and diesel engines is practically identical. ■

Engine oil

Check engine oil level

The dipstick indicates the level of oil in the engine.

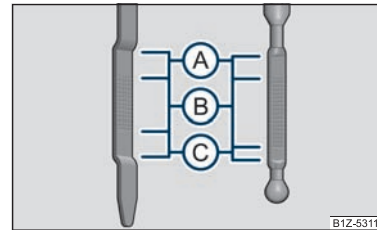



Fig. 164 Dipstick

Checking the oil level

- Ensure that the vehicle is positioned on a level surface and the engine has reached its operating temperature.
- Switch the engine off.
- Open the bonnet ⇒  in "Working in the engine compartment" on page 188.
- Wait a few minutes until the engine oil flows back into the oil sump. Take out the dipstick.
- Wipe off the dipstick with a clean cloth and insert it again fully.
- Then withdraw the dipstick again and read off the oil level.

Oil level within range **A**

- You must **not** top up the oil.

Oil level within range **B**

- You **may** top up the oil. It is possible that the oil level may then be within range **A** after doing this.

Oil level within range **C**

- You **must** top up the oil ⇒ page 190. It is sufficient, once this is done, to keep the oil level within range **B**. ▶

It is normal for the engine to consume oil. The oil consumption may be as much as 0.5 l/1 000 km depending on your style of driving and the conditions under which you operate your vehicle. The oil consumption may be slightly higher than this during the first 5 000 kilometres.

One should therefore check the oil level at regular intervals, preferably every time after the fuel tank is filled or after driving for long stretches.

We recommend maintaining the oil level within the range **(A)** - **but not above this**, if the engine has been operating at high loads, for example during a lengthy motorway trip during the summer months, towing a trailer or negotiating a high mountain pass.

The warning light in the instrument cluster will indicate whether the oil level is too low ⇒ page 29, "Engine oil pressure ". In this case, check the oil level as soon as possible. Top up with an appropriate quantity of oil.

Caution

- The oil level must on no account extend beyond the range **(A)**. Danger of damaging the catalytic converter.
- **Do not continue your journey** if for some reason it is not possible under the conditions prevailing to top up with oil. **Switch the engine off** and obtain professional assistance from a specialist garage, otherwise it could lead to severe engine damage.

Note

Engine oil specifications ⇒ page 227, "Technical Data". ■

Replenishing engine oil

- Inspecting the engine oil level ⇒ page 189.
- Unscrew the cap of the engine oil filler opening.
- Pour in a suitable grade of oil in portions of 0.5 litres ⇒ page 230, "Engine oil specifications".
- Inspect the oil level ⇒ page 189.
- Carefully screw on the cap of the filler opening and push the dipstick in fully.

WARNING

- **Avoid dripping oil onto hot parts of the engine when topping up will oil - a risk of fire!**
- **Read and observe the warning notes ⇒ page 188, "Working in the engine compartment" before working in the engine compartment.**

For the sake of the environment

The oil level must on no account extend beyond the range **(A)** ⇒ page 189. Oil will otherwise be drawn in through the crankcase ventilation and may pass through the exhaust system to atmosphere. The oil may combust in the catalytic converter and damage it. ■

Changing engine oil

The engine oil must be changed at the intervals stated in the Service schedule or according to the service interval indicator ⇒ page 17, "Service reminder indicator".

WARNING

- **Only carry out the engine oil change, if you have the required professional knowledge!**
- **Read and observe the warning notes ⇒ page 188, "Working in the engine compartment" before working in the engine compartment.**
- **First of all, let the engine cool down, wear an eye protection and gloves - risk of caustic burns due to hot oil.**

Caution

You must not pour any additives into the engine oil - risk of engine damage! Damage, which results from such product, are excluded from the warranty.

For the sake of the environment

- You must on no account pour oil into the ground or into the sewage system.
- In view of the problems involved in properly disposing of old oil, the necessary special tools and the knowledge required for such work, we recommend that you have the oil and oil filter change carried out by an authorised Škoda Service Partner. ►

i Note

After your skin has come in contact with the oil, you must thoroughly wash your skin. ■

Cooling system

Coolant

The job of the coolant is to cool the engine.

The cooling system does not require any maintenance under normal operating conditions. The coolant consists of water with a concentration of coolant additive of 40 %. This mixture not only provides antifreeze protection down to -25 °C but also protects the cooling and heating system from corrosion. It also prevents the formation of scale and significantly increases the boiling point of the coolant.

You must therefore not reduce the concentration of antifreeze agent in the coolant by adding water, also not during the summer months or in countries with a warm climate. **The concentration of coolant additive in the coolant must be at least 40 %.**

You can increase the amount of antifreeze in the coolant if a higher concentration of antifreeze is necessary for climatic reasons but only up to 60 % (antifreeze protection down to approx. -40 °C). The antifreeze protection tails off above that concentration.

Vehicles exported to countries with a cold climate (e.g. Sweden, Norway, Finland) are already factory-filled with a coolant which offers antifreeze protection down to about -35 °C. In these countries the concentration of coolant additive should be at least 50 %.

Coolant

The cooling system is factory-filled with coolant (purple in colour), which complies with the specification TL-VW 774 G.

When refilling, we only recommend you use the same antifreeze described on the antifreeze expansion tank.

Please contact an authorised Škoda Service Partner if you have any questions regarding the coolant or if you wish to fill up with a different coolant.

An authorised Škoda Service Partner can also supply you with the correct coolant additives.

Coolant capacity

Petrol engines	Capacities (in liter)
1.2 ltr./77 kW TSI - EU5	7.7
1.4 ltr./59 kW - EU4	7.1
1.4 ltr./90 kW TSI - EU5	7.7
1.6 ltr./75 kW - EU4, EU2	7.4
1.8 ltr./118 kW TSI - EU5, EU2 DDK (1.8 ltr./112 kW TSI - EU5)	8.6
2.0 ltr./147 kW TSI - EU5	8.6

Diesel engines	Capacities (in liter)
1.6 ltr./77 kW TDI CR - EU5	8.4
1.9 ltr./77 kW TDI PD - EU4, EU3	8.4
1.9 ltr./77 kW TDI PD DPF - EU4	8.4
2.0 ltr./81 kW TDI CR - EU4, EU5	8.4
2.0 ltr./103 kW TDI CR DPF - EU4, EU5	8.4
2.0 ltr./125 kW TDI CR - EU5	8.4

! Caution

- **Other coolant additives may cause operational problems which, in particular, involves significantly reducing the anticorrosion effect.**
- **Any faults or problems resulting from corrosion may cause a loss of coolant and, as a consequence of this, result in major engine damage.**

i Note

On vehicles which are fitted with an independent auxiliary heating and ventilation, the volume of the coolant is greater by approx. 1 ltr. ■

Inspecting the coolant level



Fig. 165 Engine compartment: Coolant expansion bottle

The coolant expansion bottle is located in the engine compartment on the right.

- Switch the engine off.
- Open the bonnet ⇒ page 187.
- Check the level of coolant in the coolant expansion bottle ⇒ fig. 165. The coolant level when the engine is cold must lie between the **(b)** (MIN) and **(a)** (MAX) markings. The level may also rise slightly above the **(a)** (MAX) marking when the engine is warm.

If the coolant level in the reservoir is too low, this is indicated by the warning light in the instrument cluster ⇒ page 30, "Coolant temperature/ Coolant quantity \downarrow ". We still recommend inspecting the coolant level directly at the reservoir from time to time.

Loss of coolant

A loss of coolant is first and foremost an **indication of a leak** in the system. You should not merely top up the coolant in the reservoir. It is also important to have the cooling system inspected without delay by a specialist garage.

Losses can only occur through the pressure relief in the cap of the coolant expansion bottle which is completely free of leaks if the coolant boils as a result of overheating and is forced out of the cooling system.

WARNING

Read and observe the warning notes ⇒ page 188, "Working in the engine compartment" before working in the engine compartment.

Caution

One should contact a specialist garage as soon as possible if the source of overheating itself cannot be determined and removed, since there may be grave damage to the engine. ■

Replenishing the coolant

- Switch the engine off.
- Allow the engine to cool down.
- Place a cloth over the cap of the coolant expansion reservoir ⇒ page 192, fig. 165 and unscrew the cap **carefully** by turning it to the left ⇒ .
- Top up the coolant.
- Screw the cap tight until it is heard to lock.

The coolant which you use for replenishing the system, must comply with one specific specification ⇒ page 191. Do not use an alternative additive if the specified coolant additive is not available in exceptional cases. Just top up the system with water and as soon as possible arrange adjustment to correct the mixing ratio of water and coolant additive again by a specialist garage.

Only use fresh coolant for topping up the system.

Do not fill the coolant above the mark **(a)** (max.) ⇒ page 192, fig. 165! Excess coolant which is heated up is forced out of the cooling system through the pressure relief valve in the cap of the coolant compensation bottle.

Wait until the engine has cooled down for a system which has suffered a major loss of coolant before pouring in coolant. This is necessary to avoid engine damage.

WARNING

- The cooling system is pressurized! Do not open the cap of the coolant expansion bottle if the engine is still hot - risk of scalding!
- The coolant additive and thus all of the coolant is harmful to your health. Avoid contact with the coolant. Coolant vapours are also harmful to the health. It is important, therefore, to always safely store any coolant additive in its original container out of the reach of children - risk of poisoning!
- If any splashes of coolant get into your eyes, rinse out your eyes immediately with clear water and contact a doctor as soon as possible.
- You should also consult a doctor without delay if you have inadvertently swallowed coolant.

⚠ Caution

Do not continue your journey if for some reason it is not possible under the conditions prevailing to top up with coolant. Switch the engine off and obtain professional assistance from a specialist garage, otherwise it could lead to severe engine damage.

♻ For the sake of the environment

Do not re-use coolant if it is necessary to drain the coolant in the system. It should be collected and disposed of in compliance with environmental protection regulations. ■

Radiator fan

The radiator fan may switch on suddenly.

The radiator fan is driven by an electric motor and controlled according to the coolant temperature.

The radiator fan may continue running for up to 10 minutes after the engine has been switched off - even if the ignition is also off. It may also switch on suddenly after a certain time, if

- the coolant temperature has risen because of an accumulation of heat or
- the warm engine compartment is heated up additionally by strong sunlight.

⚠ WARNING

You must therefore be aware when working in the engine compartment that the fan may switch on suddenly - risk of injury! ■

Brake fluid

Inspecting the brake fluid level

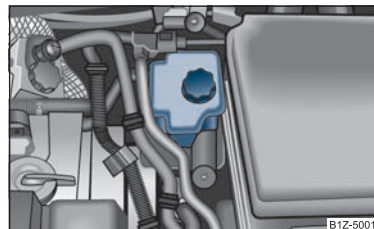

Fig. 166 Engine compartment: Brake fluid reservoir

The brake fluid reservoir is located on the left of the engine compartment. The brake fluid reservoir on right-hand steering models is positioned on the other side of the engine compartment.

- Switch the engine off.
- Open the bonnet ⇒ page 187.
- Inspect the brake fluid level in the reservoir ⇒ fig. 166. The level must be between the "MIN" and "MAX" markings.

A slight drop in the fluid level results when driving due to normal wear-and-tear and automatic adjustment of the brake pads, and is perfectly normal.

There may be an indication of a leak in the brake system, however, if the fluid level drops significantly within a short time or if it drops below the "MIN" marking. If the brake fluid level is too low, this is indicated by the warning light lighting up in the instrument cluster ⇒ page 33, "Brake system Ⓞ". In this case **stop immediately and do not drive any further! Obtain professional assistance.**

⚠ WARNING

- Read and observe the warning notes ⇒ page 188, "Working in the engine compartment" before working in the engine compartment.
- If the fluid level has dropped below the MIN marking, do not drive any further - risk of accident! Contact a Škoda dealer to obtain professional assistance. ■

Replacing brake fluid

Brake fluid absorbs moisture. This causes the fluid to absorb moisture from the surrounding air over a period of time. Excessive water in the brake fluid may be the cause of corrosion in the brake system. The water content also lowers the boiling point of the brake fluid.

One may only use new genuine brake fluid from Škoda Auto. The brake fluid must comply with one of the following standards or specifications:

- VW 50114
- FMVSS 116 DOT4
- DIN ISO 4925 CLASS 4

We recommend that you have the brake fluid replaced by an **authorised Škoda Service Partner** as part of an Inspection Service.



WARNING

Using old brake fluid can result in severe stress on the brakes because of the formation of vapour bubbles in the brake system. This greatly impairs the braking efficiency and thus also the safety of your vehicle.



Caution

Brake fluid damages the paintwork of the vehicle.



For the sake of the environment

Due to issues with disposal, the special tools and knowledge required, we recommend you have the brake fluid replaced by an **authorised Škoda Service Partner**. ■

Battery

General information

Improper handling of the vehicle battery can cause damage. We therefore recommend you have work on the vehicle battery carried out by an authorised Škoda service partner.

There is a risk of injuries, scalding, accidents and burns when carrying out any work on the battery and on the electrical system. For this reason, it is essential to comply

with the warning instructions ⇒ ⚠ stated below and with the general applicable rules of safety.



WARNING

- The battery acid is strongly corrosive and must, therefore, be handled with the greatest of care. Always wear protective gloves, eye and skin protection when handling batteries. Corrosive fumes in the air irritate the air passages and lead to conjunctivitis and inflammation of the air passages in the lungs. Battery acid corrodes dental enamel and creates deep wounds after contact with the skin which take a long time to heal. Repeated contact with diluted acids causes skin diseases (inflammations, ulcers, skin cracks). Acids coming into contact with water are diluted accompanied by significant development of heat.
- Do not tilt the battery otherwise battery electrolyte may flow out of the battery vent openings. Protect the eyes with safety glasses or a shield! There is the danger of suffering blindness! If any battery electrolyte gets into your eye, rinse out your eye immediately with clear water for several minutes. Contact a doctor without delay.
- Splashes of acid on your skin or clothes should be neutralised as soon as possible using soap suds and then rinsed with plenty of water. Contact a doctor immediately if you swallow battery electrolyte.
- Keep batteries out of the reach of children.
- Hydrogen is released when you charge a battery and a highly explosive gas mixture is produced. An explosion can be caused through sparking over during unclamping or loosening of the cable plug while the ignition is on.
- Bridging of the poles will create a short circuit (e.g. through metal objects, cables). Possible consequences of a short circuit: Melting of lead struts, explosion and burning of the battery, jets of acid spurting out.
- It is prohibited to work with a naked flame and light, to smoke or to carry out any activities which produce sparks. Avoid creating sparks when working with cables and electrical devices. Strong sparking represents a risk of injury.
- Before carrying out any work on the electrical system, switch off the engine, the ignition as well as all electrical components and disconnect the negative cable (-) on the battery. If you wish to replace a bulb it is sufficient to switch off the appropriate light.
- Never charge a frozen or thawed battery - risk of explosion and caustic burns! Replace a frozen battery.
- Never jump-start the batteries which have a too low electrolyte level - risk of explosion and caustic burns!
- Never use a battery which is damaged - risk of explosion! Immediately replace a damaged battery.

⚠ Caution

- You must only disconnect the battery if the ignition is switched off, otherwise the electrical system (electronic components) of the vehicle may be damaged. When disconnecting the battery from the electrical system of the vehicle, first disconnect the negative terminal (-) of the battery. Then disconnect the positive terminal (+).
- When reconnecting the battery, first connect the positive terminal (+) and only then the negative terminal (-) of the battery. You must on no account connect the cables wrongly - risk of a cable fire.
- Ensure that battery acid does not come into contact with the vehicle body otherwise damage could occur to the paintwork.
- Do not place the battery in direct daylight in order to protect the battery housing from the effects of ultra-violet light.
- If the vehicle has not been driven for more than 3 to 4 weeks, the battery will discharge. This is because certain electrical components consume electricity (e. g. control units) also in idle state. You can prevent the discharging of the battery by disconnecting the negative terminal or charging the battery constantly with a very low charging current.

♻ For the sake of the environment

A removed battery is a special type of waste which is harmful to the environment - contact your specialist garage regarding disposing of the battery.

ℹ Note

- Please also refer to the guidelines ⇒ page 197, also after connecting the battery.
- You should replace batteries older than 5 years. ■

Battery cover

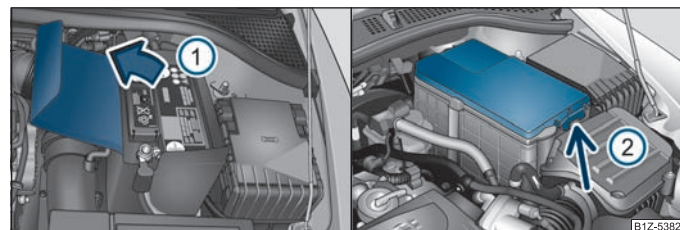

Fig. 167 Engine compartment: Polyester cover of the vehicle battery/plastic cover of the vehicle battery

The battery is located in the engine compartment in a polyester cover ⇒ fig. 167 - left or in a polyester cover ⇒ fig. 167 - right.

- Open the battery cover in direction of arrow ① ⇒ fig. 167 or press the interlock ② on the side of the battery cover, fold the cover up and remove the battery.
- The installation of the battery cover takes place in the reverse order.

The edge of the polyester battery cover ⇒ fig. 167 - left is inserted between the battery and the side wall of the battery cover when working on the battery. ■

Battery control

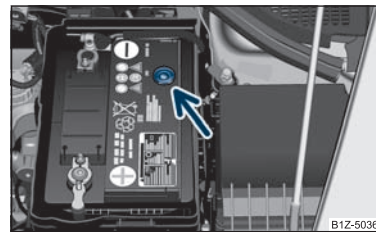

Fig. 168 The battery: Electrolyte level indicator

The battery is practically **maintenance-free** under normal operating conditions. ►

We recommend you have the electrolyte level checked by a specialist garage from time to time, especially in the following cases.

- High outside temperatures.
- Long daily drives
- After each charge ⇒ page 196.

On vehicles with a vehicle battery fitted with a colour indicator, the so-called magic eye ⇒ fig. 168, the electrolyte level can be determined by looking at the change in colour.

Air bubbles can influence the colour of the indicator. For this reason carefully knock on the indicator before carrying out the check.

- Black colour - electrolyte level is correct.
- Colourless or light yellow colour - electrolyte level too low, the battery must be replaced.



Note

- The battery electrolyte level is periodically checked by an authorised Skoda Service Partner as part of the Inspection Service.
- For technical reasons, on vehicles with the description "AGM", the electrolyte level cannot be checked.
- Vehicles with a "START-STOP" system are fitted with a battery control unit for checking the energy level for the recurring engine start. ■

Operation in winter

The battery has to provide greater amounts of electricity during the winter. It also has only part of the initial power output at low temperatures that it has at normal temperatures.

A discharged battery may already freeze at temperatures just below 0 °C.

We therefore recommend that you have the battery checked by a specialist garage before the start of winter and recharged if necessary.



WARNING

Never charge a frozen or thawed battery - risk of explosion and caustic burns. Replace a frozen battery. ■

Charging the battery

A properly charged battery is essential for reliably starting the engine.

- Read the warning notes ⇒ in "General information" on page 194 and ⇒ .
- Switch the ignition and all electrical components off.
- Only for "quick-charging": Disconnect both battery cables (first of all "negative", then "positive").
- Carefully attach the terminal clamps of the charger to the battery terminals (red = "positive", black = "negative").
- You can now plug the mains cable of the charger into the power socket and switch on the charger.
- When charging is completed: switch the charger off and unplug the mains cable from the power socket.
- Only then should you disconnect the terminal clamps of the charger.
- Reconnect the cables to the battery (first of all "positive", then "negative").

It is not normally necessary to disconnect the cables of the battery if you recharge the battery using low amperages (as for example from a **mini-charger**). Please also refer to the instructions from the charger manufacturer.

A charging current of 0.1 of the total battery capacity (or lower) is that which should be used until full charging is achieved.

It is, however, necessary to disconnect both cables before charging the battery with high amperages, so-called "**quick-charging**".

"Quick-charging" a battery is "**dangerous**" ⇒ in "General information" on page 194. It requires a **special charger and specialist knowledge. We recommend having the quick charging of vehicle batteries undertaken by a specialist garage.**

A discharged battery may already **freeze** at temperatures just below 0 °C ⇒ . We recommend that you no longer use a battery which has thawed out because the casing of the battery may be cracked through the formation of ice and this would allow battery electrolyte to flow out.

The vent plugs of the battery should not be opened for charging.



WARNING

- Never charge a frozen or thawed battery - risk of explosion and caustic burns. Replace a frozen battery. ►

⚠ WARNING (continued)

- Never charge a battery which has a too low electrolyte level - risk of explosion and caustic burns.

⚠ Caution

On vehicles with the "START/STOP" system, the pole terminal of the charger must not be connected directly to the negative terminal of the vehicle battery, but only to the engine earth ⇒ page 214, fig. 184. ■

Disconnecting and reconnecting the battery

On disconnecting and reconnecting the battery the following functions are initially deactivated or are no longer able to operate fault-free:

Operation	Operating measure
Electrical power window (operational faults)	⇒ page 45
Enter the car stereo/radio navigation system code number	see operating instructions for the car stereo/radio navigation system
Set hours	⇒ page 18
Data in the multi-functional indicator are deleted.	⇒ page 18

We recommend having the vehicle checked by an authorised Škoda Service Partner to ensure full functionality of all electrical systems. ■

Replacing the battery

When replacing a battery, the new new battery must have the same capacity, voltage (12 V), amperage and be the same size. Suitable types of vehicle battery are available from an authorised Škoda Service Partner.

We recommend you have a battery change carried out by an authorised Škoda Service partner, who will properly install the new battery and dispose of the original one.

⚠ Caution

Vehicles with a "START-STOP" system are fitted with a special battery type which allows the battery control unit to check the energy level for recurring engine start. This battery must only be replaced by a battery of the same type.

♻ For the sake of the environment

Batteries contain poisonous substances such as sulphuric acid and lead. For this reason, it must be disposed of properly. Under no circumstances must it be disposed of in the communal rubbish. ■

Windshield washer system?

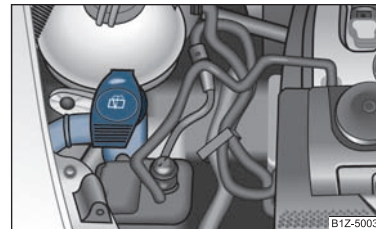

Fig. 169 Engine compartment: Windshield washer fluid reservoir

The windshield washer reservoir contains the cleaning fluid for the windscreen or rear window and for the headlamp cleaning system. The reservoir is located at the front right of the engine compartment ⇒ fig. 169.

The **filling level** of the container is about 3 litres and about 5,5 litres on vehicles which have a headlight washing system.

Clear water is not sufficient to intensively clean the windscreen and headlights. We therefore recommend using clean washing water together with the screen cleaner from Škoda genuine accessories (in winter additionally with antifreeze) which is capable of removing stubborn dirt. Follow the instructions for use on the packaging when using screen cleaning products.

You should always add antifreeze to the cleaning water in winter even if your vehicle is fitted with heated windscreen washer nozzles.

It is also possible in exceptional cases to use methylated spirits when no screen cleaner with antifreeze is available. The concentration of methylated spirits must ►

not be more than 15 %. Please note, however, that the antifreeze protection at this concentration is only adequate down to -5 °C.

**WARNING**

Read and observe the warning notes → page 188, "Working in the engine compartment" before working in the engine compartment.

**Caution**

- On no account should you add radiator antifreeze or other additives to the windscreen washer fluid.
- If the vehicle is fitted with a headlight cleaning system, you should only add cleaning products which do not attack the polycarbonate coating of the headlights to the windscreen washer fluid. Please contact an authorised Škoda Service Partner who will help you select a suitable cleaning agent. ■

Wheels and Tyres

Wheels

General information

- New tyres do not offer optimal grip at first. They should therefore be run in for about 500 km at a moderate speed and an appropriately cautious style of driving. You will also profit from longer tyre life.
- The tread depth of new tyres may differ because of design features and the configuration of the tread (depending on the type of tyre and the manufacturer).
- Drive over curbs on the side of the road and other such obstacles slowly and, where possible, at a right angle in order to avoid damage to tyres and wheel trims.
- We recommend you inspect your tyres and rims from time to time for damage (punctures, cuts, splits and bulges). Remove foreign bodies from the tyre profile.
- Damage to tyres is frequently not visible. Unusual vibrations or pulling of the vehicle to one side could be a sign of tyre damage. **Please reduce your speed immediately and stop if you suspect that a wheel is damaged.** Inspect the tyres for signs of damage (bulges, splits, etc.) If no visible damage is present, please drive at an appropriately slow speed and carefully to the nearest specialist garage in order to have your vehicle inspected.
- Also protect your tyres from contact with oil, grease and fuel.
- Immediately replace any dust caps of the valves which have got lost.
- Mark wheels before removing them so that their previous direction of running can be maintained when mounted them again.
- Always store wheels or tyres which been removed in a cool, dry and, where possible, dark place. Tyres which are not fixed to a wheel trim should be stored upright.

Unidirectional tyres

The direction of rotation of the tyres is marked by arrows on the wall of the tyre. This indicates the direction of rotation of the tyre, and it is essential that the tyres are fitted on to run in this direction. Only then are the tyres able to provide the optimal properties in terms of grip, low noise, wear-and-tear and aquaplaning.

Further information concerning the use of unidirectional tyres ⇒ page 203.

WARNING

- New tyres during the first approximately 500 km do not offer optimal grip and should therefore be run appropriately - risk of accident!
- Never drive with damaged tyres - risk of accident!

Note

Please observe the various differing legal requirements regarding tyres. ■

Tyre life



Fig. 170 An opened fuel filler flap with a tyre size and tyre inflation pressure table

The life of your tyres very much depends on the following points:

Tyre pressure

The working life of tyres will be shortened considerably if the tyres are insufficiently or over-inflated and this will have an adverse effect on the handling of your vehicle.

Correctly inflated tyres are of particular importance when travelling at **high speeds**. It is therefore good to check the tyre pressure, including that of the spare wheel, at least once a month and also before setting off on a long trip.

The tyre inflation pressures for **summer tyres** are indicated on the inside of the fuel filler flap ⇒ fig. 170. The inflation pressures for **winter tyres** are 20 kPa (0.2 bar) higher than those for summer tyres ⇒ page 202.

The tyre inflation pressure for tyres of the tyre size 205/50 R17, which are intended to be used with snow chains, is identical to the tyre inflation pressure for tyres of the tyre size 225/45 R17, see ⇒ fig. 170. ▶

The tyre pressure should be at the highest pressure specified for your vehicle at all times.

The tyre inflation pressure of the emergency spare wheel R 18 is 420 kPa (4.2 bar).

Always check the inflation pressure of tyres when cold. Do not reduce the higher pressure of warm tyres. Adapt the inflation pressure of the tyres accordingly if your vehicle is carrying a significantly higher payload.

Driving style

Fast cornering, sharp acceleration and braking (squealing tyres) increase wear-and-tear on your tyres.

Balancing wheels

The wheels of a new vehicle are balanced. There are a wide range of influences when driving which may result in an imbalance and which makes themselves felt through vibration in the steering.

You should have the wheels rebalanced since any imbalance increases wear-and-tear on the steering, the suspension and tyres. A wheel must also be rebalanced when a new tyre is fitted and each time a tyre is repaired.

Wheel alignment errors

Incorrect wheel alignment at the front and rear will not only increase wear-and-tear on the tyres but will also have an adverse effect on vehicle safety. Contact your specialist garage if you notice any unusual tyre wear.

WARNING

- If the inflation pressure is too low, the tyre must perform a higher rolling resistance. At higher speeds the tyre will warm up as a result of this. This can result in tread separation and even a tyre blowout.
- Immediately replace the damaged rims or tyres.
- Tyres which are 6 years old or more should only be fitted in exceptional cases and when adopting an appropriately cautious style of driving.



For the sake of the environment

Tyres which are insufficiently inflated increase your fuel consumption. ■

Wear indicators

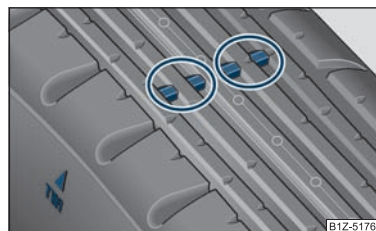

Fig. 171 Tyre tread with wear indicators

The base of the tread of the original tyres has wear indicators 1.6 mm high, installed at right angles to the direction of travel. These wear indicators are located at 6 - 8 points depending on the make and are evenly spaced around → fig. 171. Markings on the walls of the tyres through the letters "TWI", triangular symbols or other symbols identify the position of the wear indicators.

A remaining tread of just 1.6 mm, measured in the grooves of the tread next to the wear indicators, means that your tyres have reached their legally permissible minimum tread depth.

WARNING

- You must have your tyres replaced with new ones at the latest when the wear indicators have been worn down. The legally permissible minimum tread depth should be observed.
- Worn tyres do not provide the necessary adhesion to the road surface at high speeds on wet roads. One could experience "aquaplaning" (uncontrolled movements of the vehicle - "swimming" on a wet road surface). ■

Changing wheels around

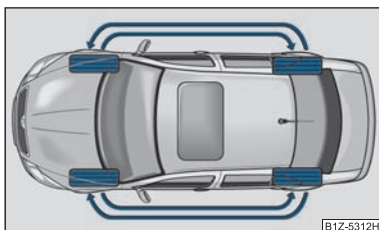

Fig. 172 Changing wheels around

If significantly greater wear is present on the front tyres, we recommend changing the front wheels around with the rear wheels as shown in the diagram ⇒ fig. 172. You will then obtain approximately the same life for all the tyres.

It may be advantageous to swap the tyres over "crosswise" when uneven wear characteristic arise on the running surfaces of the tyres (but not in the case of uni-directional tyres). We recommend you contact an authorised Škoda Service Partner. They have extensive knowledge about the possible combinations.

We recommend that you change the wheels around every 10 000 km in order to achieve even wear on all wheels and to obtain optimal tyre life. ■

New tyres and wheels

Tyres and wheel rims are important design elements. One should therefore use the tyres and wheel rims which have been released for use by Škoda Auto. They are exactly matched to the vehicle type and therefore contribute significantly to good road holding and safe driving characteristics ⇒ ⚠.

Only fit radial tyres of the same type on all 4 wheels, size (rolling circumference) and, if possible, the same tread pattern on one axle.

The authorised Škoda Service Partners have access to the most current information about which tyres we have released for use on your vehicle.

We recommend that you have any work relating to tyres or wheels carried out by an **authorised Škoda Service Partner**. The authorised Škoda Service Partners have all of the necessary special tools and replacement parts available plus the required specialist knowledge and are also in a position to properly dispose of the old tyres. A large number of authorised Škoda Service Partners also have an attractive range of tyres and wheels available.

The tyre/wheel combinations which are approved for your vehicle are indicated in your vehicle documents. Approval and licensing may differ according to the legislation prevailing in individual countries.

Proper knowledge of the tyre data makes it easier for you to select the correct type of tyre. Tyres do, for example, have the following **inscription** on their walls:

195/65 R 15 91 T

What this means is:

195	Tyre width in mm
65	Height/width ratio in /
R	Code letter for the type of tyre - R adial
15	Diameter of wheel in inches
91	Load index
T	Speed symbol

The following **speed restrictions** apply to tyres:

Speed symbol	Permissible maximum speed
S	180 km/h
T	190 km/h
U	200 km/h
H	210 km/h
V	240 km/h
W	270 km/h
Y	300 km/h

The **date of manufacture** is also stated on the tyre wall (possibly only on the *inside* of wheel):

DOT ... 20 11...

means, for example, that the tyre was manufactured in the 20th week of the year 2011.

Any **spare wheel** which differs from the tyres fitted to the vehicle (e.g. winter tyres or low-profile tyres) should only be used only for a short time in the event of a punc- ▶

ture and when adopting an appropriately cautious style of driving. It should be replaced as quickly as possible by a normal wheel.

WARNING

- Only use those tyres or wheel rims which have been approved for your model of Škoda Auto vehicle. Failure to observe this instruction will adversely affect the road safety of your vehicle - risk of accident! Approval and licencing of your vehicle on public roads may also become void as a result.
- You must on no account drive at a higher speed than is permissible for your tyres - risk of an accident resulting from tyre damage and loss of control over your vehicle.
- Tyres which are 6 years old or more should only be fitted in exceptional cases and when adopting an appropriately cautious style of driving.
- Never fit tyres which have already been used without having adequate knowledge of their previous history. Tyres age even if they have not been used at all or only very little. A spare tyre must only be used in exceptional cases and only then when adopting an appropriately cautious style of driving.
- Do not, where possible, replace individual tyres but at least replace them on both wheels of a given axle at the same time. Always fit the tyres with the deeper tread depth to the front wheels.



For the sake of the environment

Old tyres must be disposed of in conformity with the appropriate regulations.



Note

It is not normally possible to fit wheels from other models of cars for technical reasons. This may also apply in certain circumstances to the wheels of the same type of vehicle. ■

Wheel bolts

Wheels and **wheel bolts** are matched to each other in terms of design. Each time you fit other wheels - e.g. light alloy wheels or wheels with winter tyres - you must therefore also use the matching wheel bolts of the correct length and shape of spherical cap. This is essential to ensure that the wheels are tightly fitted and that the brake system operates properly.

If you retrofit **wheel trims** (or have this done), please also ensure that an adequate flow of air remains assured for cooling the brake system.

The authorised Škoda Service Partners are instructed in the technical possibilities which exist regarding converting or retrofitting tyres, wheels and wheel trims.

WARNING

- In case of incorrect treatment of the wheel bolts, the wheel can loosen when the car is moving - risk of accident!
- The wheel bolts must be clean and must turn easily. However, they must never be treated with grease or oil.
- If the wheel bolts are tightened to a too low tightening torque, the rim can loosen when the car is moving - risk of accident! A tightening torque which is too high can damage the bolts and threads and this can result in permanent deformation of the contact surfaces on the rims.

Caution

The prescribed tightening torque of the wheel bolts for steel and light alloy wheels is 120 Nm. ■

Winter tyres

The handling of your vehicle will be significantly improved when driving on wintry roads if you fit winter tyres. Summer tyres do not offer the same grip on ice, snow and at temperatures below 7 °C because of their construction (width, rubber blend, tread pattern). This particularly applies to vehicles which are equipped with **low-profile tyres** or **high-speed tyres** (code index H or V on wall of tyre).



Winter tyres must be mounted on all four wheels to obtain the best handling characteristics.

You must only fit those types of winter tyre which are approved for your vehicle. The permissible **sizes of winter tyres** are stated in your vehicle documents. Approvals may differ because of national legislation.

Please remember that the tyres should be inflated to 20 kPa (0.2 bar) more than is the case for summer tyres ⇒ page 199.

Winter tyres no longer offer the same winter performance once the **tyre tread** has worn down to a depth of about 4 mm.

Ageing also causes winter tyres to lose most of their winter performance properties - even in cases where the remaining tread depth is still clearly more than 4 mm.

Speed restrictions apply to winter tyres as well as to summer tyres ⇒ page 201, ⇒  

You can fit winter tyres of a lower speed category to your vehicle provided that you also do not drive faster than the permissible maximum speed for such tyres, even if the possible maximum speed of your vehicle is higher. The corresponding tyre category can damage the tyres when exceeding the permissible maximum speed.

Please pay attention to the notes if you decide to fit winter tyres ⇒ page 199.

You can also fit so-called "all-year tyres" instead of winter tyres.

Please contact your specialist garage if there are any points which are not clear who will be able to provide you with information regarding the maximum speed for your tyres.

WARNING

You must on no account drive your car at more than the permissible maximum speed for your winter tyres - risk of an accident resulting from tyre damage and loss of control over your car.



For the sake of the environment

Fit your summer tyres on again in good time since summer tyres offer you better grip and handling on roads which are free of snow and ice as well as at temperatures below 7 °C - the braking distance is shorter, there is less tyre noise, tyre wear is reduced and fuel consumption is reduced.



Note

Please observe the various differing legal requirements regarding tyres. ■

Unidirectional tyres

The direction of rotation of the tyres is marked by **arrows on the wall of the tyre**. This indicates the direction of rotation of the tyre, and it is essential that the tyres are fitted on to run in this direction. Only then are the tyres able to provide the optimal properties in terms of grip, low noise, wear-and-tear and aquaplaning.

Should it be necessary to fit on a spare wheel in exceptional cases with a tyre not dedicated to the running direction or in opposite running direction, please adopt a cautious style of driving as the tyre is no longer able to provide optimal grip and handling in such a situation. This particularly important on wet roads. Pay attention to the following points ⇒ page 206, "Spare wheel".

You should have the defective tyre replaced as soon as possible and restore the correct direction of rotation on all tyres ■

Snow chains

Snow chains must only be mounted on the front wheels.

When driving on wintry roads, snow chains improve not only traction, but also the braking performance.

For technical reasons, it is only permissible to fit snow chains with the following wheel/tyre combinations.

Wheel size	Depth (D)	Tyre size
6J x 15 ^{a)}	47 mm	195/65
6.5J x 15 ^{a)}	50 mm	195/65
6J x 16 ^{a)}	50 mm	205/55
6J x 17 ^{b)}	45 mm	205/50

a) Only fit snow chains with links and locks not larger than 15 mm.

b) Only fit snow chains with links and locks not larger than 9 mm.

Remove the **full wheel trims** before installing the snow chains.

Observe the different national legal regulations relating to the use of snow chains and the maximum vehicle speed with snow chains.

WARNING

Please pay attention to the information in the supplied fitting instructions of the snow chain manufacturer.



Caution

You must take the chains off as soon as you drive on roads which are free of snow. They adversely affect the handling of your vehicle, damage the tyres and are rapidly destroyed.



Note

We recommend that you use snow chains from the Škoda genuine accessories. ■

Accessories, changes and replacement of parts

General

Škoda vehicles have been built according to the latest discoveries in safety engineering. Thus one should not change the condition in which the vehicle was delivered from the manufacturer without some thought.

If you want to retrofit the vehicle with accessories, if a vehicle part is to be replaced with a new one, or when needing to make technical changes, the following instructions must be observed:

- Advise should always be obtained from an authorised Škoda Service Partner **before** buying any accessories or parts and **before** making any technical changes ⇒ .
- The guidelines and instructions issued by Škoda Auto must be observed when making technical changes.

Adhering to the prescribed procedures will prevent any kind of damage to the vehicle, and its travelling and operating safety will be maintained. The vehicle also complies with German road transport regulations (StVZO). More information is available from an authorised Škoda Service Partner who can also perform the necessary work properly.

Interference on the electronic components and their software can lead to operational faults. This interference can also impair not directly affected systems because of the networking of the electronic components. In other words, the vehicle's road-worthiness may be put at risk and increased wear on parts may arise.

Any damage which is done caused by technical changes made without consulting a Skoda dealer is excluded from the guarantee - see guarantee certificate.



WARNING

- Work or modifications on your vehicle, which have been carried out unprofessionally, can cause operational faults - risk of accident!
- We advise you, in your own interest, to only use Škoda Genuine Accessories and Škoda original parts which have been expressly approved for use on your Škoda. Reliability, safety and suitability have been established for these Škoda original parts.
- Although we constantly monitor the market, we are not able to assess or warrant the parts even though in some instances such parts may have a type approval or may have been approved by a nationally recognised testing laboratory.



Note

- Škoda Genuine Accessories and Skoda original parts can be bought from authorised Škoda Service Partners who also professionally undertake the assembly of parts which were purchased there.
- We recommend having all work undertaken by an authorised Škoda Service Partner.
- All Škoda Original parts from the original accessories catalogue, such as a towing device, child seats, etc are authorised.
- We also recommend you also buy car stereos, antennnas or other electrical accessories from an authorised Škoda Service Partner, who should also carry out the installation. ■

Breakdown assistance

Breakdown assistance

First-aid box and Warning triangle (Octavia)



Fig. 173 Placing of the warning triangle (Octavia)

The first-aid box is attached by a strap to the right-hand side of the luggage compartment.

The warning triangle can be attached to the trim panel of the rear wall with rubber straps ⇒ fig. 173.

If you wish to equip your vehicle additionally with a warning triangle, please contact a specialist garage.

Note

Pay attention to the use-by-date of the contents of the first-aid box. ■

First-aid box and warning triangle (Estate car)

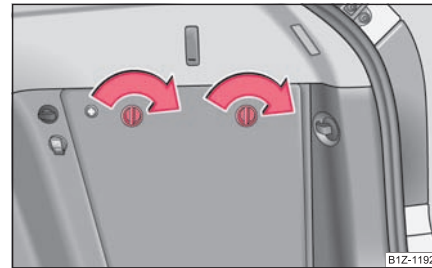

Fig. 174 Placing of the warning triangle (Estate car)

For vehicles of the type estate car the first-aid box and the warning triangle are housed in a compartment on the right side in the luggage compartment. You can open the compartment by turning the locks in the direction of arrow ⇒ fig. 174.

If you wish to equip your vehicle additionally with a warning triangle, please contact a specialist garage.

Note

Pay attention to the use-by-date of the contents of the first-aid box. ■

Fire extinguisher

The fire extinguisher is attached with straps in a holder under the driver seat.

On vehicles fitted with electrically adjustable seats, the fire extinguisher is fastened to a bracket underneath the front passenger seat.

Please read carefully the instructions which are attached to the fire extinguisher.

The fire extinguisher must be checked by an authorised person or company annually (please observe the differing legal requirements). ▶

WARNING

If the fire extinguisher is not correctly attached, in case of sudden manoeuvres or an accident it can be "thrown" through the interior compartment and cause injuries.

Note

- The fire extinguisher must comply with the relevant and valid legal requirements.
- Pay attention to the expiration date of the fire extinguisher. If the fire extinguisher is used after the expiration date, its proper function is no longer assured.
- The fire extinguisher is only supplied in certain countries within the scope of delivery. ■

Vehicle tool kit

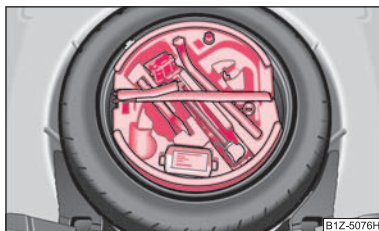

Fig. 175 Luggage compartment: Storage compartment for vehicle tool kit

The vehicle tool kit and the lifting jack with sticker are housed in a plastic box in the spare wheel ⇒ fig. 175 or in the compartment for the spare wheel. There is also space here for the removable ball for the trailer towing device. The box is attached with a strap on the spare wheel.

The vehicle tool kit contains the following parts (depending on equipment fitted):

- Wire clamps for removing the full wheel trims,
- Plastic clip for a wheel bolt cover,
- Wheel wrench,
- Towing eye,
- Adapter for the wheel bolts lock,

- Replacement lamp,
- Screwdriver for removing the fog lights¹⁹⁾.

Before placing the lifting jack back in its storage area, screw in the arm of the lifting jack fully.

WARNING

- **The factory-supplied lifting jack is only intended for your model of vehicle. On no account attempt to lift a heavier vehicle or other loads - risk of injury!**
- **Ensure that the vehicle tool kit is safely attached in the luggage compartment.**

Note

Ensure that the box is always secured with the strap. ■

Spare wheel

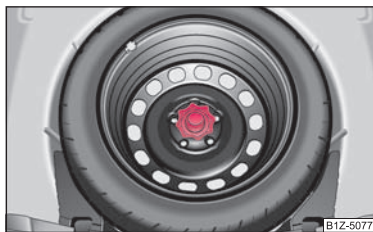

Fig. 176 Luggage compartment: Spare wheel

The spare wheel lies in a well under the floor covering of the luggage compartment and is fixed in place using special screws ⇒ fig. 176.

Before removing the spare wheel, you must take out the box with the vehicle tool kit box ⇒ fig. 175.

One should check the inflation pressure in the spare wheel (at best when generally checking the tyre air pressures - see sign on the fuel filler flap ⇒ page 199) to ensure that the spare wheel is always ready to use. ▶

¹⁹⁾ Valid for Octavia RS and Octavia Scout.

Temporary spare wheel

A warning label displayed on the rim of the temporary spare wheel indicates that your vehicle is equipped with a temporary spare wheel.

Please observe the following notes when driving with a temporary spare wheel:

- The warning label must not be covered after installing the wheel.
- Do not drive faster than 80 km/h with this spare wheel and pay particular attention while driving. Avoid accelerating at full throttle, sharp braking and fast cornering.
- The inflation pressure for this spare wheel is identical to the inflation pressure of the standard tyres. The temporary spare wheel R 18 must have an inflation pressure of 420 kPa (4.2 bar)!
- Use this spare wheel only to reach the nearest specialist garage as it is not intended for continuous use.
- No other summer or winter tyres must be mounted on the rim of the spare wheel R 18. ■

Changing a wheel

Preliminary work

The following steps should be carried out before actually changing the wheel:

- If it is necessary to change a wheel, park the vehicle as far away as possible from the traffic flow. The place you choose should be **level**.
- Have **all the occupants get out**. While changing a wheel, the occupants of the vehicle should not stand on the road (instead of behind a crash barrier).
- Apply the **handbrake** firmly.
- Engage **1st gear** or if your vehicle is fitted with an automatic gearbox, position the **selector lever into position P**.
- If a trailer is coupled, uncouple it.
- Take the **vehicle tool kit** ⇒ page 206 and the **spare wheel** ⇒ page 206 out of the luggage compartment.

WARNING

- If you find yourself in flowing traffic switch on the hazard warning lights system and place the warning triangle on the side of the road at the prescribed

WARNING (continued)

distance from your vehicle. Comply with the national legal regulations. In this way you are protecting not only yourself but also other road users.

- **Never start the engine with the vehicle sitting on the raised jack - danger of suffering injury.**

Caution

If you have to change a wheel on a slope first block the opposite wheel with a stone or similar object in order to secure the vehicle from unexpectedly rolling away.

Note

Comply with the national legal regulations. ■

Changing a wheel

Always change a wheel on a level surface as far as possible.

- Take off the full wheel trim ⇒ page 208 or the caps ⇒ page 208.
- In the case of light alloy wheels remove the wheel trim cap ⇒ page 209.
- First of all slacken the safety wheel bolt and afterwards the other wheel bolts ⇒ page 209.
- Jack up the vehicle until the wheel to be changed is clear of the ground ⇒ page 209.
- Unscrew the wheel bolts and place them on a clean surface (cloth, paper etc.).
- Take off the wheel.
- Fit on the spare wheel and tighten the wheel bolts slightly.
- Lower the car.
- Tighten the wheel bolts firmly, alternately and diagonally using the wheel wrench (crosswise) and lastly the wheel safety bolt ⇒ page 209.
- Mount the full wheel trim/wheel trim cap or the caps.

Note

- All bolts must be clean and must turn easily.
- You must never grease or oil the wheel bolts!

- When fitting on unidirectional tyres, ensure that the tyres rotate in the correct direction ⇒ page 199. ■

Subsequent steps

After changing the wheel, you must perform the following steps.

- Stow and attach the replaced wheel in the spare wheel well using a special screw ⇒ page 206, fig. 176.
- Stow the vehicle tool kit in the space provided.
- **Check the tyre pressure** on the spare wheel just mounted as soon as possible.
- Have the **tightening torque** of the wheel bolts **checked** with a torque wrench as soon as possible. Steel and light alloy wheels must be tightened to a tightening torque of **120 Nm**.
- Change the damaged wheel or consult a specialist garage about possibilities for getting repairs done.



WARNING

It is necessary to observe the guidelines given on ⇒ page 201 if the vehicle is subsequently fitted with tyres which are different to those it was fitted with at the works.



Note

- If you find, when changing the wheel, that the wheel bolts are corroded and difficult to turn, the bolts must be replaced before checking the tightening torque.
- Drive cautiously and only at a moderate speed to a workshop where the tightening torque can be checked. ■

Full wheel trim

Pulling off

- Hook the clamp found in the vehicle tool kit into the reinforced edge of the full wheel trim.
- Push the wheel key through the clamp, support the wheel key at the tyre and pull off the wheel trim.

Installing

- First press the full wheel trim onto the wheel at the valve opening provided. Then press the full wheel trim into the wheel in such a way that its entire circumference locks correctly in place.



Caution

- Use the pressure of your hand, do not knock on the full wheel trim! Heavy knocks mainly on the points where the full wheel trim has not been inserted into the wheel, can result in damage to the guide and centering elements of the full wheel trim.
- Check for yourself that the safety wheel bolt is located in the hole in the area of the valve before fitting the full wheel trim onto a steel wheel which is attached with a safety wheel bolt ⇒ page 210, "Securing wheels against being stolen". ■

Wheel bolts with caps



Fig. 177 Removing the cap.

Pulling off

- Push the plastic clip sufficiently far onto the cap until the inner catches of the clip are positioned at the collar of the cap and detach the cap ⇒ fig. 177.

Installing

- Push the caps fully onto the wheel bolts.

The caps are located in the well of the luggage compartment. ■

Wheel trim caps

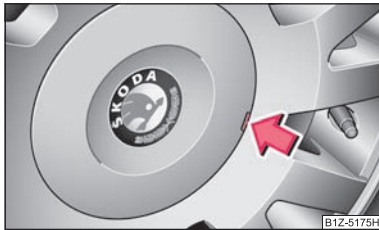

Fig. 178 Pulling off wheel trim cap on light alloy wheels

Pulling off

- Carefully remove the wheel trim cap using the wire clamp ⇒ fig. 178. ■

Slackening and tightening wheel bolts

Slacken the wheel bolts before jacking up the vehicle.



Fig. 179 Changing a wheel: Slackening wheel bolts

Slackening wheel bolts

- Insert the wheel wrench fully onto the wheel bolt ²⁰⁾.
- Grasp the end of the wrench and turn the bolt about **one** turn to the left ⇒ fig. 179. ■

²⁰⁾ Use the appropriate adapter for slackening and tightening the safety wheel bolts ⇒ page 210.

Tightening wheel bolts

- Insert the wheel wrench fully onto the wheel bolt ²⁰⁾.
- Grasp the end of the wrench and turn the bolt to the right until it is tight.

! WARNING

Slacken the wheel bolts only a little (about one turn) as long as the vehicle has not yet been jacked up - risk of an accident!

i Note

Apply pressure carefully with your **foot** to the end of the wrench if it proves difficult to slacken the bolts. Hold tight on the vehicle when doing this and ensure that you have a steady position. ■

Raise vehicle

You have to raise the vehicle with a lifting jack in order to be able to take off the wheel.

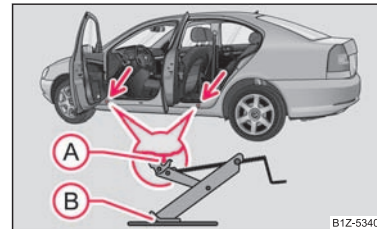

Fig. 180 Changing a wheel: Jacking points for positioning lifting jack

Position the lifting jack by selecting the jacking point which is closest to the wheel to be removed ⇒ fig. 180. The jacking point is located directly below the engraving in the lower sill. The engraving is only visible after opening the door.

- Position the lifting jack below the jacking point and move it up until its claw is positioned directly below the vertical web of the lower sill.
- Align the car jack so that its claw grasps the web of the lower sill (A) and the base plate (B) is resting flat on the floor.
- Turn the lifting jack up further until the wheel is just clear of the ground. ▶

Ground below the lifting jack which is soft and slippery can cause the vehicle to slip off the jack. It is therefore always necessary to place the lifting jack on a solid surface or use a wide and stable base. Use a non-slip base (e.g. a rubber foot mat) if the surface is smooth, such as cobbled stones, a tiled floor, etc.

WARNING

- Always raise the vehicle with the doors closed - risk of injury!
- Take suitable measures to prevent the base of the lifting jack from slipping off - risk of injury!
- Not positioning the lifting jack at the specified points can result in damage to the vehicle. The jack can also slip off if it does not have sufficient grip - risk of injury!
- It is important to support the vehicle with suitable supporting blocks if you wish to work under the lifted vehicle - risk of injury! ■

Securing wheels against being stolen

You need a special adapter for slackening the safety wheel bolts.

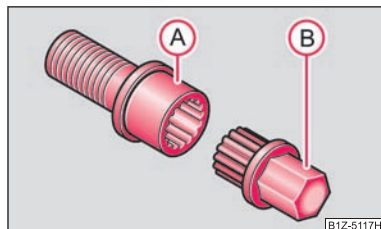

Fig. 181 Illustration image: Safety wheel bolt with adapter

- Pull off the full wheel trim/cap from the wheel hub or cap from the safety wheel bolt.
- Insert the adapter (B) with its toothed side fully into the inner tooting of the safety wheel bolt (A) right down in such a way that only the outer hexagon is jutting out ⇒ fig. 181.
- Insert the wheel wrench fully onto the adapter (B).
- Slacken the wheel bolt, or tighten it firmly ⇒ page 209.

- Reinstall the full wheel trim/wheel cap after removing the adapter or place the cap onto the safety wheel bolt.
- Have the **tightening torque checked** with a torque wrench as soon as possible. Steel and light alloy wheels must be tightened to a tightening torque of **120 Nm**.

The safety wheel bolts on vehicles fitted with them (one safety wheel bolt per wheel) can only be loosened or tighten up by using the adapter provided.

It is meaningful to note the code number hammered into the rear side of the adapter or the rear side of the safety wheel bolts. You can obtain a replacement adapter from an authorised Škoda Service Partner, if necessary, by quoting this number.

We recommend that you always carry the adapter for the wheel bolts with you in the vehicle. It should be stowed in the vehicle tool kit.

Caution

Damage can occur to the adapter and safety wheel bolt if the safety wheel bolt is tightened up too much.

Note

The set of safety wheel bolts can be obtained from an authorised Škoda Service Partner. ■

Tyre repair kit

General information

The tyre repair kit is located in a box under the carpet in the luggage compartment.

Use the tyre repair kit to reliably repair tyre damage caused by foreign bodies or a puncture with diameters up to 4 mm. Do not remove foreign bodies, e.g. screws or nails, from the tyre!

The repair can be undertaken on the vehicle immediately.

The repair with the tyre repair kit is **not at all intended to replace** a permanent repair on the tyre, this repair only serves to reach the next specialist garage.

Do not use the tyre repair kit:

- to repair wheel damage,
- in outside temperatures of less than -20 °C (-4 °F),



- with tears or punctures greater than 4 mm in size,
- to repair damage to the tyre wall,
- when driving with very low tyre pressure or with a completely flat tyre,
- if the use-by-date (see inflation bottle) has passed.

WARNING

- If you find yourself in flowing traffic switch on the hazard warning lights system and place the warning triangle on the side of the road at the prescribed distance from your vehicle. Comply with the national legal regulations. In this way you are protecting not only yourself but also other road users.
- Park the vehicle as far away as possible from the traffic flow. Park on as flat and firm a surface as possible.
- A tyre filled with sealant has the same driving characteristics as a standard tyre.
- Do not drive faster than 80 km/h, 50 mph.
- Avoid accelerating at full throttle, sharp braking and fast cornering.
- Check the tyre inflation pressure after driving 10 minutes!
- Sealant is hazardous to health. Remove immediately if it comes into contact with the skin.

For the sake of the environment

Used sealant or sealant whose expiry date has passed must be disposed of in accordance with environmental protection regulations.

Note

- Observe the manufacturer's usage instructions for the tyre repair kit.
- You can purchase a new bottle of sealant from the range of the Škoda original accessories.
- Change the wheel that was repaired using the tyre repair kit or consult a specialist garage about possibilities for getting repairs done. ■

Components of the tyre repair kit

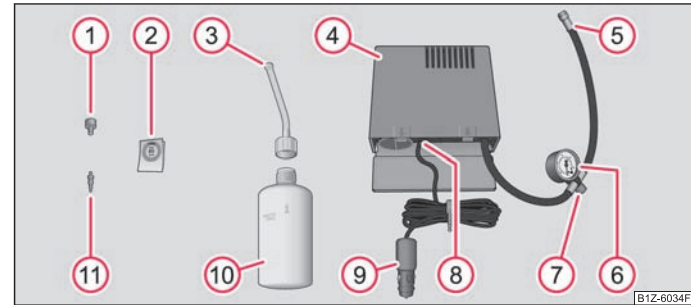

Fig. 182 Components of the tyre repair kit

The tyre repair kit is made up of the following parts:

- ① Valve remover
- ② Sticker with speed designation "max. 80 km/h"/"max. 50 mph"
- ③ Inflation hose with plug
- ④ Compressor
- ⑤ Tyre inflation hose
- ⑥ Tyre inflation pressure indicator
- ⑦ Air release valve
- ⑧ ON and OFF switch
- ⑨ 12 volt cable connector
- ⑩ Tyre inflator bottle with sealing agent
- ⑪ Replacement valve core

The valve remover ① has a slot at its lower end which fits into the valve core. This is the only way in which you can remove and re-install the valve core from the tyre valve. The same also applies to the replacement valve core ⑪. ■

Preparing to use the tyre repair kit

Before using the tyre repair kit, carry out the following preparatory work:

- Park the vehicle as far away as possible from the traffic flow. Park on as flat and firm a surface as possible. ▶

- Have **all the occupants get out**. While changing a wheel, the occupants of the vehicle should not stand on the road (instead of behind a crash barrier).
- Switch off the engine and engage **1st gear** or if your vehicle is fitted with an automatic gearbox, position the **selector lever into position P**.
- Apply the **handbrake** firmly.
- Check whether you can carry out the repairs with the tyre repair kit ⇒ page 210, "General information".
- If a trailer is coupled, uncouple it.
- Remove the **tyre repair kit** from the luggage compartment.
- Stick the sticker (2) ⇒ page 211, fig. 182 on the dash panel in view of the driver.
- Do not remove the foreign body, e.g. screw or nail, from the tyre.
- Unscrew the valve cap.
- Use the valve remover (1) to remove the valve core and place it down on a clean surface. ■

Seal and inflate tyres

Sealing tyres

- Forcefully shake the tyre inflator bottle (10) ⇒ page 211, fig. 182 several times.
- Firmly screw inflation hose (3) onto the tyre inflator bottle in a clockwise direction (10). The film on the cap is pierced automatically.
- Remove the plug from the inflation hose (3) and plug the open end fully into the tyre valve.
- Hold the bottle (10) with the floor facing upwards and fill the whole sealing agent in the tyre inflator bottle into the tyres.
- Remove the empty tyre inflator bottle from the valve.
- Screw the valve core back into the tyre valve using the valve remover (1).

Pumping up the tyres

- Screw the tyre inflation hose (5) ⇒ page 211, fig. 182 of the air compressor firmly onto the tyre valve.
- Check whether the air release valve (7) is closed.
- On vehicles fitted with a manual gearbox, move the gearshift lever into Neutral.
- Start the engine and run it in idle.

- Plug the connector (9) into 12 Volt socket ⇒ page 81.
- Switch on the air compressor with the ON and OFF switch (8).
- Allow the air compressor to run until reaching a pressure of 2.0 - 2.5 bar. Maximum run time of 8 minutes ⇒ (1)!
- Switch off the air compressor with the ON and OFF switch.
- If you cannot reach an air pressure of 2.0 - 2.5 bar, unscrew the tyre inflation hose (5) from the tyre valve.
- Drive the vehicle approx. 10 metres forwards or backwards to allow the sealing agent to distribute in the tyre.
- Screw the tyre inflation hose of the air compressor (5) firmly back onto the tyre valve and repeat the inflation procedure.
- If you cannot reach the required tyre inflation pressure here either, this means the tyre has sustained too much damage. You cannot seal with tyre with the breakdown kit ⇒ ⚠.
- Switch off the air compressor with the ON and OFF switch.
- Remove the tyre inflation hose (5) from the tyre valve.

After reaching a tyre inflation pressure of 2.0 - 2.5 bar, drive at a maximum speed of 80 km/h (50 mph).

Check the tyre inflation pressure after driving 10 minutes ⇒ page 213, "Check after driving for 10 minutes".



WARNING

- During inflation, the tyre inflation hose and air compressor may get hot- risk of injury!
- Do not place hot tyre inflation hoses or hot air compressors on flammable materials - risk of fire!
- If you cannot inflate the tyre to at least 2.0 bar, this means the damage sustained was too serious. The sealing agent cannot be used to seal the tyre. Do not drive the vehicle. Get professional assistance.



Caution

Switch off the air compressor after running 8 minutes at the latest - danger of overheating! Allow the air compressor to cool a few moments before switching it on again. ■

Check after driving for 10 minutes

Check the tyre inflation pressure after driving 10 minutes.

If the tyre inflation pressure is 1.3 bar or less:

- Do not drive the vehicle! You cannot properly seal with tyre with the breakdown kit.
- Contact a Škoda dealer to obtain professional assistance.

If the tyre inflation pressure is 1.3 bar or more:

- Adjust the tyre inflation pressure to the correct value (see inside of fuel filler cap).
- Continue driving carefully to the nearest specialist garage at a maximum speed of 80 km/h (50 mph). ■

Jump-starting

Initial steps

You can use the battery of another vehicle for jump-starting yours if the engine does not start because the battery on your vehicle is flat. You will require jump-start cables for this purpose.

Both batteries must have a rated voltage of 12 V. The **capacity** (Ah) of the battery supplying the power must not be significantly less than the capacity of the discharged battery in your vehicle.

Jump-start cables

Only use jump-start cables which have an adequately large cross-section and insulated terminal clamps. Please pay attention to the manufacturer's instructions.

Positive cable - colour coding in the majority of cases red.

Negative cable - colour coding in the majority of cases black.

WARNING

- A discharged battery may already freeze at temperatures just below 0 °C. In case of frozen battery carry out no jump-starting - risk of explosion!

WARNING (continued)

- Please pay attention to the warning instructions relating to working in the engine compartment ⇒ page 188, "Working in the engine compartment".

Note

- There must not be any contact between the two vehicles otherwise current may flow as soon as the negative terminals are connected.
- The discharged battery must be properly connected to the system of the vehicle.
- Switch off any mobile phone, pay attention to the instructions for use of the mobile phone in such a situation.
- We recommend you buy jump-start cables from a car battery specialist. ■

Start engine

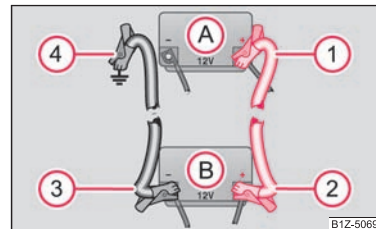

Fig. 183 Jump-starting using the battery from another vehicle: A - flat vehicle battery, B - battery providing current

It is important to connect the jump-start cables in the correct order:

Connecting positive terminals

- Attach one end ① ⇒ fig. 183 to the positive terminal of the discharged battery (A).
- Attach the other end ② to the positive terminal of the battery supplying the power (B).

Connecting negative terminal and engine block

- Attach one end ③ to the negative terminal of the battery supplying the power (B).

- Attach the other end ④ to a solid metal part which is connected firmly to the engine block, or to the engine block itself.

Starting engine

- Start the engine of the vehicle providing current and run the engine at idling speed.
- Now start the engine of the vehicle with the discharged battery.
- Interrupt the attempt at starting an engine after 10 seconds if it does not start right away and wait for about 30 seconds before repeating the attempt.
- Disconnect the cables on the engine in exactly the **reverse order** they were connected up.



WARNING

- The non-insulated parts of the terminal clamps must never make contact with each other. Furthermore, the cable connected to the positive terminal of the battery must not come into contact with electrically conducting parts of the vehicle - risk of a short circuit!
- Do not affix the jump starting cables to the negative terminal of the discharged battery. There is the risk of detonating gas seeping out the battery being ignited by the strong spark which results from the engine being started.
- Run the jump-start cables so that they cannot be caught by any rotating parts in the engine compartment.
- Do not bend over the batteries - risk of caustic burns!
- The vent screws of the battery cells must be tightened firmly.
- Keep any sources of ignition (naked flame, smouldering cigarettes etc.) away from the battery - risk of an explosion!
- Never jump-start the batteries which have a too low electrolyte level - risk of explosion and caustic burns! ■

Jump-starting in vehicles with the "START-STOP" system

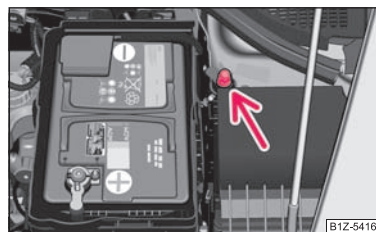

Fig. 184 Jump-starting on vehicles with the START-STOP system

On vehicles with the "START STOP" system, the negative cable of the charger must never be connected directly to the negative pole of the vehicle battery, but only to the engine earth ⇒ fig. 184. ■

Towing the vehicle

General

Vehicles with manual transmission can be towed in with a tow bar or a tow rope or with the front or rear wheels raised.

Vehicles with automatic transmission can be towed in with a tow bar or a tow rope or with the front wheels raised. If the vehicle is raised at rear, the automatic gearbox is damaged!

Vehicles with four-wheel drive can be towed in with a tow bar or a tow rope or with the front wheels raised.

A tow **bar** is safest way of towing a vehicle and also minimizes any shocks. You can use a tow **rope** only if a suitable tow bar is not available.

Refer to the following guidelines when towing:

Driver of the towing vehicle

- Release the clutch particularly gently when starting off or depress the accelerator particularly gently if your vehicle is fitted with an automatic gearbox.
- On vehicles with manual transmission, only push down on the accelerator pedal once the rope is taught. ▶

The maximum towing speed is **50 km/h**.

Driver of the towed vehicle

- Switch the ignition on so that the steering wheel is not blocked and you can also operate the turn signal lights, the headlight flasher, the windscreen wipers and windscreen washer system.
- Take the vehicle out of gear or move the selector lever into position **N** if your vehicle is fitted with an automatic gearbox.

Note that the brake servo unit and power steering only operate if the engine is running. You will require significantly greater physical force to depress the brake pedal and to steer the vehicle if the engine is not running.

When using a tow rope, always ensure that the tow rope is always kept taught.

! Caution

- Do not tow start the engine - danger of damaging the engine. On vehicles with a catalytic converter, unburnt fuel may get into the catalytic converter where it may ignite. This in turn may damage or destroy the catalytic converter. You can use the battery of another vehicle as a jump-start aid ⇒ page 213, "Jump-starting".
- If the gearbox of your vehicle no longer contains any oil because of a defect, your vehicle must only be towed in with the driven wheels raised clear of the ground, or on a special vehicle transporter or trailer.
- The vehicle must be transported on a special vehicle or trailer if it is not possible to tow in the vehicle in the way described or if the towing distance is greater than 50 km.
- To protect both vehicles when tow-starting or towing, the tow rope should be elastic. Thus one should only use plastic fibre rope or a rope made out of a similarly elastic material.
- One should be constantly vigilant not to allow impermissibly high towing forces or jerky loadings. There is always a risk of excessive stresses and damage resulting at the points to which you attach the tow rope or tow bar when you attempt to tow a vehicle which is not standing on a paved road.
- Attach the tow rope or the tow bar only to the **towing eyes** provided for this purpose ⇒ page 215, "Front towing eye" and ⇒ page 216, "Rear towing eye".

i Note

- Towing another vehicle requires a certain amount of practice. Both drivers should be familiar with the particular points about towing a vehicle. Unskilled drivers should not attempt to tow in another vehicle or to be towed in.

- When towing, respect the national legal provisions, especially those which relate to the identification of the towing vehicle and the vehicle being towed.
- The tow rope must not be twisted as it may in certain circumstances result in the front towing eye being unscrewed out of your vehicle. ■

Front towing eye

The towing eye is stored in the box of the vehicle tool kit.

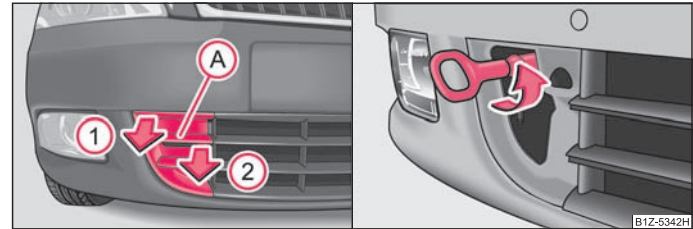

Fig. 185 Front bumper: protective grille/installing the towing eye

Carefully remove the cover as follows.

- Guide the fingers into the opening **A** ⇒ fig. 185.
- By pulling in the direction of arrow **1**, first of all slacken the cover in the upper area on the side to the fog lights.
- Afterwards, also slacken the cover on the other side in the direction of arrow **2** and remove it.
- Screw in the towing eye by hand to the left up to the stop ⇒ fig. 185 - right and tighten. For tightening, we recommend that you use for example the wheel wrench, the lashing eye of another vehicle or a similar object which you can push through the eye.
- In order to reinstall the cover after screwing out the towing eye, first of all insert it starting on the side facing the marking. Then press the cover closed on the side facing the fog light. The cover must engage firmly.

! Caution

The towing eye must always be screwed in fully and firmly tightened, otherwise the towing eye can tear when towing in or tow-starting! ■

Front towing eye for Octavia RS and Octavia Scout

The towing eye is stored in the box of the vehicle tool kit.

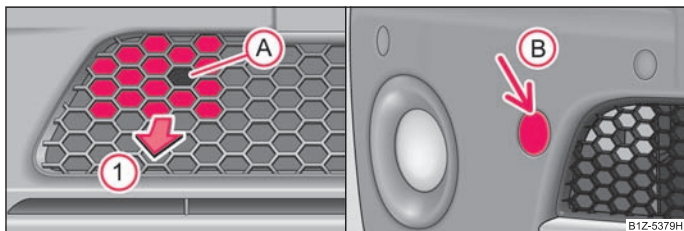

Fig. 186 Front bumper Octavia RS: Protective grille/Octavia Scout: Cover

Octavia RS

- Guide one finger into the opening (A) of the grille ⇒ fig. 186.
- Unlock the cover by pulling it in direction (1) and remove it.
- Screw in the towing eye by hand to the left up to the stop ⇒ page 215, fig. 185 - right and tighten it as much as possible.
- Put the cover in place after screwing out the towing eye again and press into place. The cover must engage firmly.

Octavia Scout

- Press on the upper part of the cover (B) and remove it.
- Screw in the towing eye by hand to the left up to the stop ⇒ page 215, fig. 185 - right and tighten it as much as possible. For tightening, we recommend that you use for example the wheel wrench, the lashing eye of another vehicle or a similar object which you can push through the eye.
- Put the cover in place after screwing out the towing eye again and press into place. The cover must engage firmly.

⚠ Caution

The towing eye must always be screwed in fully and firmly tightened, otherwise the towing eye can tear when towing in or tow-starting. ■

Rear towing eye

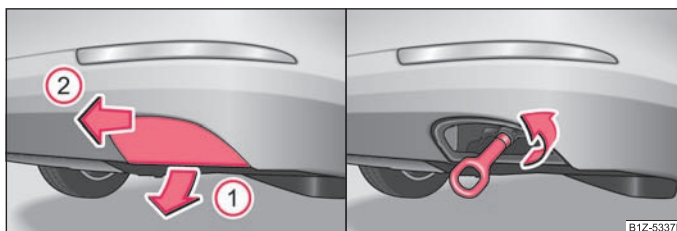

Fig. 187 Rear bumper: Remove cover/rear bumper: Installing the towing eye

- Unlock the bottom part of the cover by pulling it downwards in direction of arrow (1) ⇒ fig. 187.
- Unlock the upper part of the cover by pulling it in direction of arrow (2) and remove it.
- Screw in the towing eye by hand to the left up to the stop ⇒ fig. 187 - right and tighten it as much as possible. For tightening, we recommend that you use for example the wheel wrench, the lashing eye of another vehicle or a similar object which you can push through the eye.
- In order to reinstall the cover after screwing out the towing eye, first of all insert the upper part of the cover and then press in the lower part. The cover must engage firmly.

⚠ Caution

The towing eye must always be screwed in fully and firmly tightened, otherwise the towing eye can tear when towing in or tow-starting. ■

Fuses and light bulbs

Electric fuses

Replacing fuses in the dash panel

Defect fuses must be replaced.

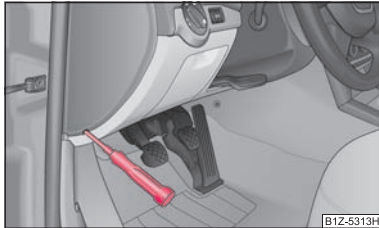

Fig. 188 Fuse cover: left side of the dash panel

Individual electrical circuits are protected by fuses. The fuses are located on the left side of the dash panel behind the safety cover and under the cover in the engine compartment on the left.

- Switch the ignition off and also the electrical component affected.
- Use a screwdriver to take off the fuse cover on the side of the dash panel ⇒ fig. 188 or the fuse cover in the engine compartment ⇒ page 217.
- Find out which fuse belongs to the relevant component ⇒ page 219, "Fuse assignment in the dash panel" or ⇒ page 218, "Fuse assignment in engine compartment".
- Take the plastic clip out of its fixture in the fuse cover, insert it onto the respective fuse and pull out this fuse.
- Defect fuses can be detected by their melted metal strips. Replace the defect fuse by a new fuse of the **same** ampere number.
- Fit on the fuse cover again.

We recommend that you always have the small box of replacement fuses in your vehicle. You can obtain replacement fuses from the range of Škoda original parts or from a specialist garage.

Colour coding of fuses

Colour	Maximum amperage
light brown	5
brown	7.5
red	10
blue	15
yellow	20
white	25
green	30
orange	40
red	50

⚠ Caution

- Never attempt to "repair" fuses and also do not replace them with a fuse of a higher amperage - risk of fire! This may also cause damage at another part of the electrical system.
- Have the electrical system checked as quickly as possible by a specialist garage if a newly inserted fuse blows again after a short time. ■

Fuse cover in engine compartment

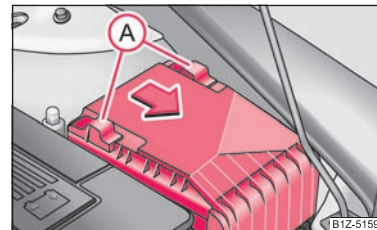



Fig. 189 Fuse cover in engine compartment

On some vehicles, the battery cover must be removed before removing the fuse cover ⇒ page 195.

Removing fuse cover

- Move the circlips (A) ⇒ page 217, fig. 189 as far as the stop, the symbol  appears behind the circlip and remove the cover.

Installing fuse cover

- Position the fuse cover on the fuse box and push the circlips (A) as far as the stop - the symbol  is visible behind the circlip.

Caution

- When unlocking and locking the fuse cover, it must be pressed on the sides to the box, otherwise damage can occur to the locking mechanism.
- Carefully position the fuse cover in the engine compartment. If the cover was not correctly positioned, water can get into the fuses and this results in a damage to the vehicle! ■

Fuse assignment in engine compartment

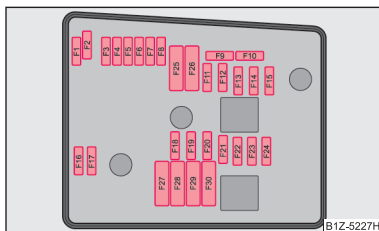

Fig. 190 Schematic representation of fuse carrier in engine compartment

Certain electrical components are only standard on certain vehicle model versions or only suppliable as optional equipment for certain models.

No.	Power consumer
F1	Not assigned
F2	Control unit for automatic gearbox DQ 200
F3	Measuring circuit
F4	Valves for ABS
F5	Control unit for automatic gearbox
F6	Instrument cluster, windshield wiper lever and turn signal light lever
F7	Power supply terminal 15, Starter
F8	Radio
F9	Not assigned
F10	Engine control unit, Main relay
F11	Control unit for auxiliary heating
F12	Control unit for CAN databus
F13	Engine control unit
F14	Ignition
F15	Lambda probe glow plug system relay
F16	Central control unit, right main headlight, right rear light unit
F17	Horn
F18	Amplifier for digital sound processor
F19	Front window wiper
F20	Water pump valve for fuel dosing
F21	Lambda probe Vacuum pump
F22	Clutch pedal switch, brake pedal switch
F23	Secondary air pump Air mass meter Fuel high pressure pump

No.	Power consumer
F24	Activated charcoal filter, exhaust gas recirculation valve
F25	Pump for ABS
F26	Central control unit, left main headlight, left rear light unit
F27	Secondary air pump Glow plug system
F28	Not assigned
F29	Power supply terminal 30
F30	Terminal X ^{a)}

a) In order not to drain the battery unnecessarily when starting the engine, the electrical components of this terminal are automatically switched off.

Fuse assignment in the dash panel

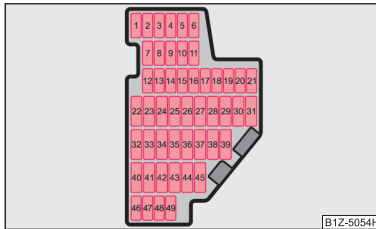

Fig. 191 Schematic representation of the fuse carrier in the dash panel

Certain electrical components are only standard on certain vehicle model versions or only suppliable as optional equipment for certain models.

No.	Power consumer
1	Diagnostic socket, Engine control unit, Electrical fuel pump
2	Control unit for ABS, ESP
3	Airbag
4	Heating, Air conditioning system, Reversing lights

No.	Power consumer
5	Control unit for headlamp beam adjustment
6	Instrument cluster, control unit for automatic gearbox, control unit for electromechanical power steering, parking aid, Haldex coupling
7	Not assigned
8	Not assigned
9	Not assigned
10	Not assigned
11	Not assigned
12	Central locking control unit
13	Diagnostic socket, Light switch
14	Control unit for automatic gearbox, Selector lever lock
15	Central control unit - interior lights
16	Climatronic
17	Not assigned
18	Rear window wiper
19	Control unit for trailer detection
20	Not assigned
21	Cornering lights for the left and right side
22	Air blower for Climatronic
23	Front power window
24	Cigarette lighter
25	Rear window heater Rear window heater, Auxiliary heating (auxiliary heating and ventilation)
26	Power socket in the luggage compartment
27	Fuel pump relay, Injection valves (diesel engine)
28	Radio

No.	Power consumer
29	Engine control unit, Crankcase ventilation heater
30	Control unit for automatic gearbox
31	Vacuum pump
32	Rear power window
33	Electric sliding/tilting roof
34	Control unit for convenience functions
35	Anti-theft alarm system
36	Headlight cleaning system
37	Front seat heating
38	Heated rear seats
39	Instrument cluster, windshield wiper lever and turn signal light lever
40	Air blower for heating and air conditioning
41	Not assigned
42	Not assigned
43	Towing device
44	Towing device
45	Towing device
46	Seat heaters
47	Relay for auxiliary heating
48	Phone
49	Light switch

Electrically adjustable seats are protected by **automatic circuit breakers**, which switch on again automatically after a few seconds after the overload has been eliminated. ■

Bulbs

Changing bulbs

The relevant lamp must always be switched off before a light bulb is replaced.

Defect light bulbs should only be replaced with light bulbs of the same type. The designation is located on the light socket or the glass bulb.

Changing certain bulbs is not something which you can do yourself, but requires to be done by a specialist. Other parts of the vehicle must be removed in order to change the light bulbs. This applies, in particular, to bulbs which can only be reached from the engine compartment.

We therefore recommend that you have any bulbs changed by an authorised Škoda Service Partner or, in exceptional cases, by calling on other professional assistance.

Please note that the engine compartment is a hazardous area ⇒ page 188, "Working in the engine compartment".

We recommend that you always have a small box of replacement bulbs in your vehicle. You can obtain replacement bulbs from Škoda original accessories or from a specialist garage.

A stowage place for the bulbs is located in the box in the spare wheel.

Fitted with a xenon headlight

Change of bulbs on vehicles with Xenon lights (low beam lights, parking lights and main beam lights) should be undertaken by a specialist garage.

Bulb - Overview

Front headlight	Halogen headlight	Xenon headlight
Low beam	H7	D1S
Main beam	H1	
Parking lights	W5W/W5W BL	
Daylight driving lights	PY21W SLL/LED ^{a)}	
Turn signals	PY21W	
Fog lights	H8/HB4 ^{a)}	

^{a)} Octavia RS, Octavia Scout

Light unit (Octavia)	Bulb
Reversing light	P21W
Turn signals	PY21W
Twin filament light bulb for the brake lights and tail lights	P21/4W
Twin filament bulbs for the rear fog light and rear parking light.	P21/4W
Parking lights	W3W
Rear light unit (estate car)	Bulb
Reversing lights, brake lights, parking light and rear fog light	P21W
Turn signals	PY21W
Parking lights	W3W
Others	Bulb
Side turn signal lights	LED
Licence plate light	C5W
3 Brake light	LED
Entry lighting	W5W
front interior lighting	C10W
Reading lights	W5W
Rear interior lighting	C10W
Luggage compartment light	W5W
Door warning light	C5W
Lighting in storage compartment	C3W

WARNING

- Bulbs H7 and H1 are pressurised and may burst when changing the bulb - risk of injury!
- It is recommended to wear gloves and safety glasses when changing a bulb.
- Gas discharge bulbs (xenon bulbs) operate with a high voltage, professional knowledge is required - danger to life!

Caution

Do not take hold of the glass bulb with naked fingers (even the smallest amount of dirt reduces the working life of the light bulb). Use a clean cloth, serviette or something similar.

Note

This Owner's Manual only describes the replacement of bulbs where it is assumed that no major complications will arise. Other light bulbs should be changed by your specialist garage. ■

Front headlight

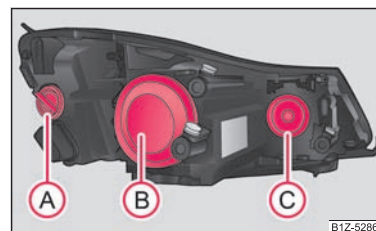

Fig. 192 Front headlight: Fitting position of the bulbs

Positions of the light bulbs in the front headlight ⇒ fig. 192.

- Ⓐ - Front turn signal light
- Ⓑ - parking lights and low beam
- Ⓒ - main beam light ■

Removing the headlight

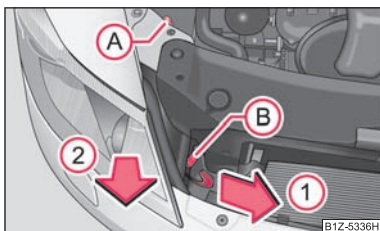

Fig. 193 Front headlight: Fitting position of the bulbs

The headlight must be removed in order to change the light bulb of the parking lights, low beam lights and main beam lights as well as the turn signal lights.

Removing the headlight

- Switch the ignition and all lights off.
- Open the bonnet ⇒ page 187.
- Unscrew the plastic nut **A** ⇒ fig. 193.
- Pull the fuse **B** in upward direction.
- Pull the locking lever of the headlight as far as the stop in the direction of arrow **1**.
- Unplug the plug connector and carefully take out the headlight in the direction of arrow **2**.

Installation takes place in the reverse order.



Note

After installing the headlight, the headlight setting must be checked by a specialist garage. ■

Turn signal light (at the front)



Fig. 194 Removing the light bulb for the turn signal light

Changing light bulb for turn signal light (at the front)

- Switch the ignition and all lights off.
- Remove the headlight ⇒ page 222.
- Turn the socket in the direction of arrow **OPEN (open)** and take it out together with the light bulb for the turn signal light ⇒ fig. 194.
- Press the defective light bulb into the socket, turn to the left and remove.
- Press a new light bulb into the socket and turn the light bulb to the right as far as the stop.
- Insert the socket with the changed light bulb into the headlight and secure it by turning in the direction of arrow **CLOSE (close)** to the right.



Note

After installing the headlight, the headlight setting must be checked by a specialist garage. ■

Front parking lights and low beam

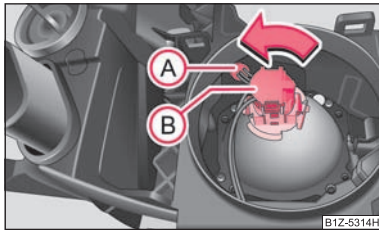

Fig. 195 Removing the bulbs for the parking and low beam light

Removing the light bulb for the parking light

- Switch the ignition and all lights off.
- Remove the headlight ⇒ page 222.
- Remove the protective cap (B) ⇒ page 221, fig. 192.
- Remove the socket (A) ⇒ fig. 195.
- Take the faulty bulb out of the fixture and insert a new one.
- Insert the protective cap.

Removing the light bulb for the low beam light

- Switch the ignition and all lights off.
- Remove the headlight ⇒ page 222.
- Remove the protective cap (B) ⇒ page 221, fig. 192.
- Turn the connector with the light bulb (B) up to the stop towards the left and remove ⇒ fig. 195.
- Replace the lamp, insert the connector with the new lamp and turn to the right up to the stop.
- Insert the protective cap.

Note

- In order to facilitate the removal of the socket with the bulb for the parking light, we recommend to remove first of all the bulb for the low beam light.

- After installing the headlight, the headlight setting must be checked by a specialist garage. ■

Main beam

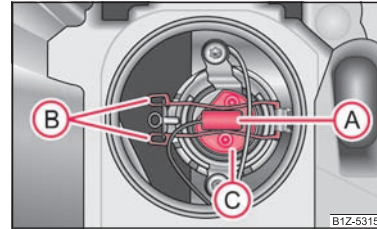

Fig. 196 Removing the light bulb for the main beam light

- Switch the ignition and all lights off.
- Remove the headlight ⇒ page 222.
- Remove the protective cap (C) ⇒ page 221, fig. 192.
- Unplug plug (A) ⇒ fig. 196.
- Press the wire clamps (B) in the direction of the headlight and then unhook them to the side.
- Remove the light bulb (C) and insert the new light bulb in such a way that the fixing lugs of the light bulb socket fit into the recesses at the reflector.

Installation takes place in the reverse order.

Note

After installing the headlight, the headlight setting must be checked by a specialist garage. ■

Fog lights and daylight driving lights

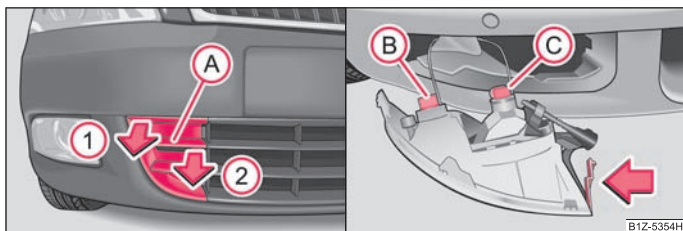

Fig. 197 Front bumper: Protective grille/removing the fog light

Plug **B** - Bulb for daylight driving light ⇒ fig. 197. Plug **C** - Bulb for fog lights.

Removing the cover

- Switch the ignition and all lights off.
- Guide the fingers into the opening **A** ⇒ fig. 197.
- By pulling in the direction of arrow **1**, first of all slacken the cover in the upper area on the side to the fog lights.
- Afterwards, also slacken the cover on the other side in the direction of arrow **2** and remove it.

Removing the fog light

- Guide your hand into the opening, in which the cover was located, and press the spring bolt ⇒ fig. 197 - right.
- Take out the fog light.
- Turn the connector with the light bulb up to the stop towards the left and remove.
- Replace the lamp, insert the connector with the new lamp and turn to the right up to the stop.
- For the installation, first of all insert the fog light with the interlock to the side far away from the marking of the vehicle.
- Press into place the headlight onto the side facing the marking.

- In order to reinstall the cover, first of all insert one part of the cover starting on the side facing the marking. Then press the cover closed on the side facing the fog light. The cover must engage firmly. ■

Cover of fog lights Octavia RS, Octavia Scout

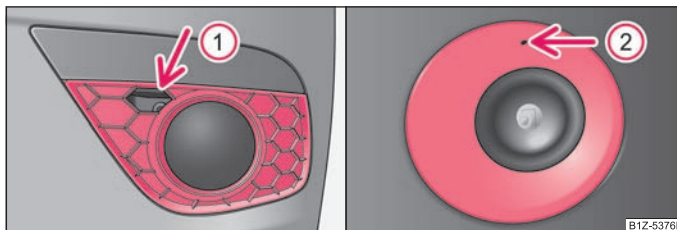

Fig. 198 Front bumper: Octavia RS/Octavia Scout

Removing the cover - Octavia RS

- Switch the ignition and all lights off.
- Guide one finger into the opening **1** ⇒ fig. 198 and remove the cover.

Removing the cover - Octavia Scout

- Switch the ignition and all lights off.
- Guide the wire clamp from the vehicle tool kit into the opening **2** above the fog light and remove the cover. ■

Fog lights Octavia RS, Octavia Scout

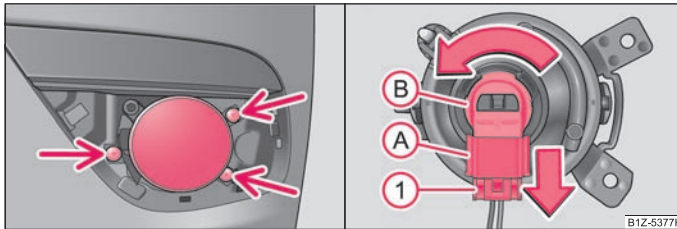

Fig. 199 Front bumper: Fog lights/fog lights: Replacing light bulb

Removing the fog light

- Use the screwdriver to unscrew the screws from the car tool kit ²¹⁾ ⇒ fig. 199 - left.
- Take out the fog light.

Changing the bulb and installing the fog light

- Press the locking button ① of the plug ① and remove the plug from the socket ②.
- Turn the socket ② with the bulb to the left up to the stop and take it out.
- Change the bulb, insert again the socket with the new bulb and turn it to the right up to the stop.
- Connect the plug ① to the socket ②.
- Screw in the screws again and insert the cover. The cover must engage firmly.

²¹⁾ Valid for Octavia RS and Octavia Scout.

Licence plate light

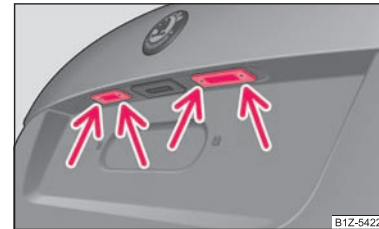

Fig. 200 Remove the licence plate light

- Open the boot lid and unscrew the light glass ⇒ fig. 200.
- Take the defective bulb out of the holder and insert a new one.
- Insert the glass cover of the light again and press it down to the stop - ensure that the sealing rubber is correctly seated.
- Screw on the light glass slightly. ■

Light unit (Octavia)



Fig. 201 Luggage compartment: Cover for the lamp holder/removing the lamp holder

Changing light bulbs in the lamp holder

- Switch the ignition and all lights off.
- Unlock the locking button and open the cover of the lamp holder ⇒ fig. 201 - left. ►

- Press the catches in the direction of arrow and take out the lamp holder ⇒ page 225, fig. 201 - right.
- Press the defective light bulb into the socket, turn to the left and remove.
- Press a new light bulb into the socket and turn the light bulb to the right as far as the stop.
- Insert the lamp holder in such a way that the catches lock in place in the housing.
- Close and lock the cover of the lamp holder.

Change the light bulb for the parking light

- Switch the ignition and all lights off.
- Unlock the locking button and open the cover of the lamp holder ⇒ page 225, fig. 201 - left.
- Take the defective light bulb (arrow ① or ②) out of the housing and replace it with a new one.
- Close and lock the cover of the lamp holder. ■

- Press the defective light bulb into the socket, turn to the left and remove.
- Press a new light bulb into the socket and turn the light bulb to the right as far as the stop.
- Insert the lamp holder in such a way that the catches lock in place in the housing.
- Take out the light bulbs from the rear parking light (arrow ① and ②).
- Close the cover of the lamp holder.

Change the light bulb for the parking light

- Switch the ignition and all lights off.
- Open the lamp holder cover ⇒ fig. 202 - left.
- Take the defective light bulb (arrow ① or ②) out of the housing and replace it with a new one.
- Close the cover of the lamp holder. ■

Rear light unit (estate car)

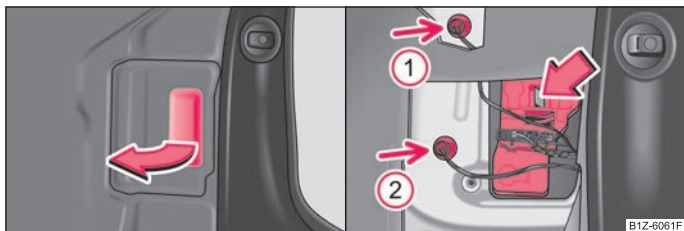

Fig. 202 Luggage compartment: Cover for the lamp holder/removing the lamp holder

Changing light bulbs in the lamp holder

- Switch the ignition and all lights off.
- Open the lamp holder cover ⇒ fig. 202 - left.
- Take out the light bulbs of the tail light (arrow ① and ②).
- Press the catch in the direction of arrow and take out the lamp ⇒ fig. 202 - right.

Technical data

Technical Data

General information

The details given in the official vehicle registration documents always take precedence over the details in the Owner's Manual. Please refer to the official vehicle registration documents or consult an authorised Škoda Service Partner concerning the engine with which your vehicle is equipped. ■

Used abbreviations

Abbreviation	Importance
kW	Kilowatt, measuring unit for the engine output
rpm	Engine revolutions per minute
Nm	Newton meter, measuring unit for the engine torque
g/km	discharged quantity of carbon dioxide in grams per driven kilometre
TSI	Petrol engine with a turbocharger and a direct fuel injection system
TDI PD	Diesel engine with turbocharger and injection system unit injector
TDI CR	Diesel engine with turbocharger and injection system Common Rail
M5/M6	5-speed/6-speed manual gearbox
AG6	6-speed automatic gearbox
DQ6/DQ7	6 speed-/7 speed automatic gearbox DSG
DPF	Diesel particle filter
N1	The vehicles of this category are designed and constructed for conveying goods with a maximum weight of 3.5 tons

Performances

The listed performance values were determined without performance-reducing equipment, e.g. air conditioning system. ■

Weight

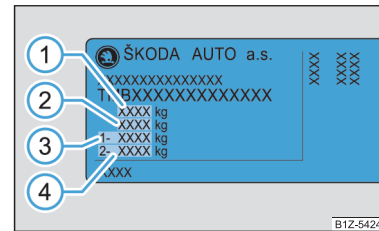

Fig. 203 Type plate

The indicated unloaded weight is for orientation purposes only. It is for the basic equipment variant of the vehicle not including special features or accessories.

The unladen weight contains a fuel tank topped up to 90 % and a driver weight of 75 kg.

It is possible to calculate the approximate loading capacity from the difference between the permissible total weight and the unloaded weight.

You need to include the following into the loading capacity:

- Passengers,
- all luggage and other loads,
- Loads on the roof incl. roof rack,
- When using the towing device, the corresponding drawbar load (max. 75 kg).

The following specifications are listed on the type plate ⇒ fig. 203: ▶

- ① Permissible gross weight
- ② The permissible overall weight of the vehicle/trailer combination when the vehicle is being operated with a trailer
- ③ Maximum permissible front axle load
- ④ Maximum permissible rear axle load

The type plate is fixed to the lower part of the columns on the driver's side, between the front and rear doors.

⚠ WARNING

Do not exceed the permissible overall weight - risk of accident and damage to the vehicle. ■

Identification details

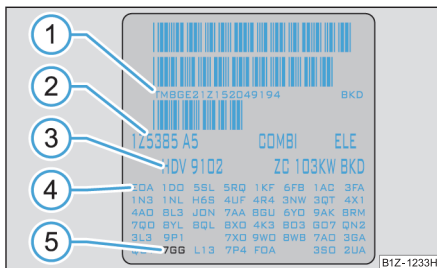

Fig. 204 Vehicle data sticker

Vehicle data sticker

The vehicle data sticker → fig. 204 is located on the floor of the luggage compartment and is also stated in the Service schedule.

The vehicle data sticker contains the following data:

- ① Vehicle identification number (VIN)
- ② Vehicle type
- ③ Gearbox code, paint number, interior equipment number, engine output, engine code
- ④ Partial description of the vehicle
- ⑤ 7GG, 7MB, 7MG - vehicles with DPF ⇒ page 167

Vehicle identification number (VIN)

The vehicle identification number - VIN (vehicle body number) is stamped into the engine compartment on the right hand shock absorber dome. This number is also located on a sign on the lower left hand edge below the windscreen.

Engine number

The engine number is stamped into the engine block.

Type plate (production plate)

The type plate is located in the lower area of the left centre column.

Sticker on inside of fuel filler flap

The stickers are affixed to the inside of the fuel filler flap and contain the following information:

- The prescribed types of fuel,
- Tyre size,
- Tyre pressure. ■

Fuel consumption according to the ECE standards and EU guidelines

Depending on the range of the special equipment, style of driving, traffic situation, weather influences and vehicle condition, the consumption values which in practice result when using the vehicle can deviate from the indicated values.

Urban traffic

The consumption measurement in urban traffic begins with starting of the cold engine. Afterwards the normal urban traffic is simulated.

Non-urban traffic

For the consumption measurement in non-urban traffic the vehicle, as in daily motoring, is accelerated and braked several times in all gears. The vehicle speed changes within the range from 0 to 120 km/h.

Combined traffic

The consumption value in the combined traffic consists of 37 % from the value for the urban traffic and of 63 % from the value for the non-urban traffic. ■

Dimensions

Dimensions (mm)

	OCTAVIA	OCTAVIA GreenLine	OCTAVIA RS	ESTATE CAR	ESTATE CAR GreenLine	ESTATE CAR RS	ESTATE CAR 4x4	SCOUT
Length	4569	4569	4597	4569	4569	4599	4569	4584
Width	1769	1769	1769	1769	1769	1769	1769	1784
Width including exterior mirror	2018	2018	2018	2018	2018	2018	2018	2018
Height	1462 1485 ^{a)} 1449 ^{b)}	1462 1449 ^{b)}	1447	1468 1490 ^{a)} 1455 ^{b)}	1468 1455 ^{b)}	1451	1495 1520 ^{a)}	1533
Clearance	140 164 ^{a)} 125 ^{b)}	140 125 ^{b)}	127	140 164 ^{a)} 125 ^{b)}	140 125 ^{b)}	128	138 163 ^{a)}	179
Wheel base	2578	2578	2578	2578	2578	2578	2578	2578
Track gauge front/rear	1541/1514	1535/1508	1528/1508	1541/1514	1535/1508	1528/1508	1541/1514	1531/1500

a) The value corresponds to the status with rough road package.

b) The value corresponds to the status with SPORT package.

Engine oil specifications

The grade of engine oil should be selected in accordance with precise specifications.

The engine of your vehicle has been factory-filled with a high-grade oil which you can use throughout the year - except in extreme climatic regions.

You can mix various oils together with each other when refilling with oil. This does not, however, apply for models with flexible service intervals (QG1).

Engine oils are, of course, undergoing continuous further development. Thus the information stated in this Owner's Manual is only correct at the time of publication.

Authorised Škoda Service Partners are informed by Škoda Auto about current changes. This why you should always have engine oil changed by an authorised Škoda Service Partner.

The specifications (VW standards) stated in the following must be indicated separately or together with other specifications on the bottle.

Engine oil specifications for models with flexible service intervals (QG1)

Petrol engines	Specification	Content ^{a)}
1,2 ltr./77 kW - EU5	VW 504 00	3.6
1.4 ltr./59 kW - EU4	VW 503 00, VW 504 00	3.2
1.4 ltr./90 kW TSI - EU5	VW 503 00, VW 504 00	3.6
1.6 ltr./75 kW - EU4, EU2	VW 503 00, VW 504 00	4.5
1.6 ltr./75 kW MultiFuel - EU4, EU2	VW 503 00, VW 504 00	4.5
1.8 ltr./118 kW TSI - EU5, EU2 DDK (1.8 ltr./112 kW TSI - EU5)	VW 504 00	4.6
2.0 ltr./147 kW TSI - EU5	VW 504 00	4.6

^{a)} Oil capacity with oil filter change. Inspect oil level when filling; do not fill up too much. The oil level must be between the markings ⇒ page 189.

Diesel engines	Specification	Content ^{a)}
1.6 ltr./77 kW TDI CR - EU5	VW 507 00	4.3
1.9 ltr./77 kW TDI PD - EU4, EU3	VW 506 01, VW 507 00	3.8
1.9 ltr./77 kW TDI PD DPF - EU4	VW 507 00	4.3
2.0 ltr./81 kW TDI CR - EU4, EU5	VW 507 00	4.3
2.0 ltr./103 kW TDI CR DPF - EU4, EU5	VW 507 00	4.3
2.0 ltr./125 kW TDI CR - EU5	VW 507 00	4.3

Engine oil specifications for vehicles with fixed service intervals (QG2)

Petrol engines	Specification	Content ^{a)}
1,2ltr./77 kW - EU5	VW 502 00	3.6
1.4 ltr./59 kW - EU4	VW 501 01, VW 502 00	3.2
1.4 ltr./90 kW TSI - EU5	VW 501 01, VW 502 00	3.6
1.6 ltr./75 kW - EU4, EU2	VW 501 01, VW 502 00	4.5
1.6 ltr./75 kW MultiFuel - EU4, EU2	VW 502 00	4.5
1.8 ltr./118 kW TSI - EU5, EU2 DDK (1.8 ltr./112 kW TSI - EU5)	VW 502 00	4.6
2.0 ltr./147 kW TSI - EU5	VW 502 00	4.6

^{a)} Oil capacity with oil filter change. Inspect oil level when filling; do not fill up too much. The oil level must be between the markings ⇒ page 189.

If the oils specified above are not available, oils according to ACEA A2 or ACEA A3 can be used once for refilling.

Diesel engines	Specification	Content ^{a)}
1.6 ltr./77 kW TDI CR - EU5	VW 507 00	4.3
1.9 ltr./77 kW TDI PD - EU4, EU3	VW 505 01	3.8
1.9 ltr./77 kW TDI PD DPF - EU4	VW 507 00	4.3

Diesel engines	Specification	Content ^{a)}
2.0 ltr./81 kW TDI CR - EU4, EU5	VW 507 00	4.3
2.0 ltr./103 kW TDI CR DPF - EU4, EU5	VW 507 00	4.3
2.0 ltr./125 kW TDI CR - EU5	VW 507 00	4.3

If the oils specified above are not available, oils according to ACEA B3 or ACEA B4 can be used once for refilling.

Caution

Only the above-mentioned oils may be used on vehicles with flexible service intervals (QG1). We recommend always refilling with oil of the same specification since this will maintain the properties of the oil. In exceptional cases, you must top up only once engine oil complying with Specification VW 502 00 (only for petrol engines) or Specification VW 505 01 (only for diesel engines) to maximum 0.5 litres. You must not use other engine oils - risk of engine damage!

Note

- Before a long drive we recommend that you purchase and carry with you engine oil which complies with the specification for your vehicle. Consequently, you will always have the correct engine oil for refilling.
- We recommend using a preservative from the Škoda original accessories offered by your Škoda dealer.
- For further information - see Service schedule. ■

Engine 1.2 I/77 kW TSI - EU5

Output (kW per rpm)	Max. torque (Nm per rpm)	Number of cylinders/Displacement (cm ³)
77/5000	175/1550-4100	4/1197

Performances	OCTAVIA M6	OCTAVIA DQ7	ESTATE CAR M6	ESTATE CAR DQ7
Maximum speed (km/h)	192	192	191	191
Acceleration 0 - 100 km/h (s)	10.8	10.8	10.9	10.9

Fuel consumption (in ltr./100 km) and CO₂ (in g/km)

	OCTAVIA M6	OCTAVIA DQ7	ESTATE CAR M6	ESTATE CAR DQ7
Urban	7.1	7.0	7.1	7.0
Non-urban	4.9	5.2	4.9	5.2
Combination	5.7	5.9	5.7	5.9
CO ₂ emission - combination	134	136	134	136

Weight (in kg)

	OCTAVIA M6	OCTAVIA DQ7	ESTATE CAR M6	ESTATE CAR DQ7
Permissible gross weight	1865	1890	1880	1905
Unladen weight ready for work	1265	1290	1280	1305
Permissible trailer loads, trailer braked	1200 ^{a)} /1400 ^{b)} (1200 ^{a)b)} ^{c)}			
Permissible trailer loads, trailer unbraked	600			

a) Uphills up to 12 %

b) Uphills up to 8 %

c) Vehicles of the group N1.

Engine 1.4 I/59 kW - EU4, EU5

Output (kW per rpm)	Max. torque (Nm per rpm)	Number of cylinders/Displacement (cm ³)
59/5000	132/3800	4/1390

Performances	OCTAVIA EU4	OCTAVIA EU5	ESTATE CAR EU4	ESTATE CAR EU5
Maximum speed (km/h)	173	174	172	173
Acceleration 0 - 100 km/h (s)	14.2	14.3	14.3	14.4

Fuel consumption (in ltr./100 km) and CO₂ (in g/km)

Urban	9.6	8.5	9.6	8.5
Non-urban	5.6	5.1	5.6	5.1
Combination	7.0	6.4	7.0	6.4
CO ₂ emission - combination	167	149	167	149

Weight (in kg)

Permissible gross weight	1855	1750	1870	1755
Unladen weight ready for work	1255	1255	1270	1270
Permissible trailer loads, trailer braked	900 ^{a)} /1100 ^{b)}		(900 ^{a)} / ^{b)} / ^{c)} 900 ^{a)} /1100 ^{b)}	900 ^{a)} /1100 ^{b)}
Permissible trailer loads, trailer unbraked	600			

^{a)} Uphills up to 12 %

^{b)} Uphills up to 8 %

^{c)} Vehicles of the group N1.

Engine 1.4 I/90 kW TSI - EU5

Output (kW per rpm)	Max. torque (Nm per rpm)		Number of cylinders/Displacement (cm ³)	
90/5000	200/1500-4000		4/1390	
Performances	OCTAVIA M6	OCTAVIA DQ7	ESTATE CAR M6	ESTATE CAR DQ7
Maximum speed (km/h)	203 (205) ^{a)}	202	202 (204) ^{a)}	201
Acceleration 0 - 100 km/h (s)	9.7 (9.8) ^{a)}	9.7	9.8 (9.9) ^{a)}	9.8
Fuel consumption (in ltr./100 km) and CO ₂ (in g/km)				
Urban	8.5 (7.2) ^{a)}	8.0	8.5 (7.2) ^{a)}	8.0
Non-urban	5.0 (4.9) ^{a)}	5.3	5.0 (4.9) ^{a)}	5.3
Combination	6.3 (5.8) ^{a)}	6.3	6.3 (5.8) ^{a)}	6.3
CO ₂ emission - combination	148 (134) ^{a)}	147	148 (134) ^{a)}	147
Weight (in kg)				
Permissible gross weight	1910 (1925) ^{a)}	1930	1925 (1940) ^{a)}	1945
Unladen weight ready for work	1310 (1325) ^{a)}	1330	1325 (1340) ^{a)}	1345
Permissible trailer loads, trailer braked	1200 ^{b)} /1400 ^{c)} (1200 ^{b)c)} ^{d)}			
Permissible trailer loads, trailer unbraked	600			

a) The value corresponds to the status with Greentec package.

b) Uphills up to 12 %

c) Uphills up to 8 %

d) Vehicles of the group N1.

Engine 1.6 I/75 kW - EU2, EU4, EU5

Output (kW per rpm)		Max. torque (Nm per rpm)			Number of cylinders/Displacement (cm ³)			
75/5600		148/3800			4/1595			
Performances	OCTAVIA M5 EU4	OCTAVIA M5 EU4	OCTAVIA M5 MultiFuel	OCTAVIA AG6	ESTATE CAR M5 EU4	ESTATE CAR M5 EU5	ESTATE CAR M5 MultiFuel	ESTATE CAR AG6
Maximum speed (km/h)	190			184	188	189	188	184
Acceleration 0 - 100 km/h (s)	12.3			14.1	12.4	12.4	12.4	14.2
Fuel consumption (in ltr./100 km) and CO ₂ (in g/km)								
Urban	10.0	9.6	9.4/13.0 ^{a)}	11.2	10.0	9.7	9.6/13.2 ^{a)}	11.2
Non-urban	5.8	5.5	5.5/7.5 ^{a)}	6.1	5.8	5.6	5.7/7.7 ^{a)}	6.1
Combination	7.4	7.1	7.0/9.5 ^{a)}	7.9	7.4	7.2	7.2/9.7 ^{a)}	7.9
CO ₂ emission - combination	176	166	162/157 ^{a)}	188	176	168	167/162 ^{a)}	188
Weight (in kg)								
Permissible gross weight	1880			1915	1895			1930
Unladen weight ready for work	1280			1315	1295			1330
Permissible trailer loads, trailer braked	1200 ^{b)} /1400 ^{c)} (1200 ^{b)} c) ^{d)}							
Permissible trailer loads, trailer unbraked	600							

^{a)} Biofuel Ethanol E85

^{b)} Uphills up to 12 %

^{c)} Uphills up to 8 %

^{d)} Vehicles of the group N1.

Engine 1.8 I/118 kW TSI - EU5, EU2 DDK (1.8 I/112 kW TSI - EU5)

Output (kW per rpm)	Max. torque (Nm per rpm)	Number of cylinders/Displacement (cm ³)
118/4500-6200 (112/4300-6200) ^{a)}	250/1500-4500 (250/1500-4200) ^{a)}	4/1798

a) 1.8 ltr./112 kW TSI

Performances	OCTAVIA M6	OCTAVIA DQ7	ESTATE CAR M6	ESTATE CAR DQ7	ESTATE CAR 4x4 M6	SCOUT M6
Maximum speed (km/h)	223 (219) ^{a)}		222 (218) ^{a)}		218 (214) ^{a)}	211 (208) ^{a)}
Acceleration 0 - 100 km/h (s)	7.8 (8.1) ^{a)}		7.9 (8.2) ^{a)}		8.1 (8.4) ^{a)}	8.4 (8.7) ^{a)}
Fuel consumption (in ltr./100 km) and CO₂ (in g/km)						
Urban	9.5	9.1	9.5	9.1	10.3	10.2
Non-urban	5.5	5.4	5.5	5.4	6.2	6.4
Combination	6.9	6.6	6.9	6.6	7.7	7.8
CO ₂ emission - combination	158	155	158	155	180	182
Weight (in kg)						
Permissible gross weight	1950	1970	1965	1985	2070	2130
Unladen weight ready for work	1350	1370	1365	1385	1470	1530
Permissible trailer loads, trailer braked	1300 ^{b)} /1400 ^{c)} (1300 ^{b)} / ^{c)} ^{d)}				1500 ^{b)} /1600 ^{c)} (1500 ^{b)} / ^{c)} ^{d)}	
Permissible trailer loads, trailer unbraked	650					

a) 1.8 ltr./112 kW TSI

b) Uphills up to 12 %

c) Uphills up to 8 %

d) Vehicles of the group N1.

Engine 2.0 I/147 kW TSI - EU5, EU2 DDK

Output (kW per rpm)	Max. torque (Nm per rpm)	Number of cylinders/Displacement (cm ³)
147/5100-6000	280/1700-5000	4/1984

Performances	OCTAVIA RS M6	OCTAVIA RS DQ6	ESTATE CAR RS M6	ESTATE CAR RS DQ6
Maximum speed (km/h)	242	240	239	237
Acceleration 0 - 100 km/h (s)	7.2	7.2	7.3	7.3

Fuel consumption (in ltr./100 km) and CO₂ (in g/km)

	OCTAVIA RS M6	OCTAVIA RS DQ6	ESTATE CAR RS M6	ESTATE CAR RS DQ6
Urban	10.2	10.4	10.2	10.4
Non-urban	5.9	6.2	5.9	6.2
Combination	7.5	7.7	7.5	7.7
CO ₂ emission - combination	175	180	175	180

Weight (in kg)

	OCTAVIA RS M6	OCTAVIA RS DQ6	ESTATE CAR RS M6	ESTATE CAR RS DQ6
Permissible gross weight	1915/1980 ^{a)}	1935/2000 ^{a)}	1930/1995 ^{a)}	1950/2015 ^{a)}
Unladen weight ready for work	1435	1455	1450	1470
Permissible trailer loads, trailer braked	1400 ^{b)} /1600 ^{c)} (1400 ^{b)} / ^{c)} ^{a)}			
Permissible trailer loads, trailer unbraked	650			

^{a)} Vehicles of the group N1.

^{b)} Uphills up to 12 %

^{c)} Uphills up to 8 %

Engine 1.6 I/77 kW TDI CR - EU5

Output (kW per rpm)	Max. torque (Nm per rpm)				Number of cylinders/Displacement (cm ³)		
77/4400	250/1500-2500				4/1598		
Performances	OCTAVIAM5	OCTAVIA M5 GreenLine	OCTAVIA DQ7	ESTATE CAR M5	ESTATE CAR M5 GreenLine	ESTATE CAR DQ7	ESTATE CAR 4x4 M6
Maximum speed (km/h)	191 (192) ^{a)}	192	191	190 (191) ^{a)}	191	190	186
Acceleration 0 - 100 km/h (s)	11.3	11.4	11.4	11.4	11.4	11.5	12.2
Fuel consumption (in ltr./100 km) and CO ₂ (in g/km)							
Urban	5.7 (5.1) ^{a)}	4.7	5.6	5.7 (5.1) ^{a)}	5.3	5.6	6.7
Non-urban	3.9 (3.6) ^{a)}	3.4	4.2	3.9 (3.6) ^{a)}	3.5	4.2	4.6
Combination	4.5 (4.2) ^{a)}	3.8	4.7	4.5 (4.2) ^{a)}	4.1	4.7	5.4
CO ₂ emission - combination	119 (109) ^{a)}	99	123	119 (109) ^{a)}	107	123	141
Weight (in kg)							
Permissible gross weight	1950 (1960) ^{a)}	1990	1975	1965 (1975) ^{a)}	2005	1990	2075
Unladen weight ready for work	1350 (1360) ^{a)}	1390	1375	1365 (1375) ^{a)}	1405	1390	1475
Permissible trailer loads, trailer braked	1400 ^{b)} /1600 ^{c)} (1400 ^{b)} / ^{c)} ^{d)}						1600 ^{b)} /1700 ^{c)} (1600 ^{b)} / ^{c)} ^{d)}
Permissible trailer loads, trailer unbraked	650						

a) The value corresponds to the status with Greentec package.

b) Uphills up to 12 %

c) Uphills up to 8 %

d) Vehicles of the group N1.

Engine 1.9 I/77 kW TDI PD - EU4

Output (kW per rpm)	Max. torque (Nm per rpm)	Number of cylinders/Displacement (cm ³)
77/4000	250/1900	4/1896

Performances	OCTAVIAM5	OCTAVIA DQ6	ESTATE CAR M5	ESTATE CAR DQ6	ESTATE CAR 4x4 M6
Maximum speed (km/h)	192	189	191	189	181
Acceleration 0 - 100 km/h (s)	11.8	12.2	11.9	12.3	12.9

Fuel consumption (in ltr./100 km) and CO₂ (in g/km)

Urban	6.3	7.7	6.3	7.7	7.7
Non-urban	4.2	5.0	4.2	5.0	4.9
Combination	4.9	5.9	4.9	5.9	6.0
CO ₂ emission - combination	130	155	130	155	159

Weight (in kg)

Permissible gross weight	1955/1945 ^{a)}	1980/1970 ^{a)}	1970	1995	2080
Unladen weight ready for work	1355	1380	1370	1395	1480
Permissible trailer loads, trailer braked	1400 ^{b)} /1600 ^{c)} (1400 ^{b)} / ^{c)} ^{a)}				1600 ^{b)} /1700 ^{c)} (1600 ^{b)} / ^{c)} ^{a)}
Permissible trailer loads, trailer unbraked	650				

^{a)} Vehicles of the group N1.

^{b)} Uphills up to 12 %

^{c)} Uphills up to 8 %

Engine 2.0 I/81 kW TDI CR - EU4, EU5

Output (kW per rpm)	Max. torque (Nm per rpm)		Number of cylinders/Displacement (cm ³)		
81/4200	280/1750-2750		4/1968		
Performances	OCTAVIA M5 EU4	OCTAVIA M6 EU5	ESTATE CAR M5 EU4	ESTATE CAR M6 EU5	ESTATE CAR 4x4 M6 EU5
Maximum speed (km/h)	195	195	194	194	189
Acceleration 0 - 100 km/h (s)	11.0	11.0	11.1	11.1	11.6
Fuel consumption (in ltr./100 km) and CO ₂ (in g/km)					
Urban	6.5	6.1	6.5	6.2	7.2
Non-urban	4.3	4.0	4.3	4.1	4.7
Combination	5.0	4.8	5.0	4.9	5.6
CO ₂ emission - combination	132	126	132	129	148
Weight (in kg)					
Permissible gross weight	1971	1995	1986	2010	2100
Unladen weight ready for work	1371	1395	1386	1410	1500
Permissible trailer loads, trailer braked	1400 ^{a)} /1600 ^{b)} (1400 ^{a)} b) ^{c)}				1600 ^{a)} /1700 ^{b)} (1600 ^{a)} b) ^{c)}
Permissible trailer loads, trailer unbraked	650				

a) Uphills up to 12 %

b) Uphills up to 8 %

c) Vehicles of the group N1.

Engine 2.0 I/103 kW TDI CR - EU4, EU5

Output (kW per rpm)	Max. torque (Nm per rpm)	Number of cylinders/Displacement (cm ³)
103/4000 - EU4 103/4200 - EU5	320/1750 - 2500	4/1968

Performances	OCTAVIA M6	OCTAVIA DQ6	ESTATE CAR M6	ESTATE CAR DQ6	ESTATE CAR 4x4 M6	ESTATE CAR 4x4 DQ6	SCOUT M6	SCOUT DQ6
Maximum speed (km/h)	211	209	210	208	204	203	199	197
Acceleration 0 - 100 km/h (s)	9.5	9.6	9.6	9.7	9.8	9.9	10.1	10.2
Fuel consumption (in ltr./100 km) and CO₂ (in g/km)								
Urban	6.1	6.7	6.2	7.0	7.2	7.3	7.4	7.4
Non-urban	4.0	4.5	4.1	4.6	4.7	5.2	5.1	5.5
Combination	4.8	5.3	4.9	5.4	5.6	5.9	5.9	6.2
CO ₂ emission - combination	126	138	129	143	148	156	155	162
Weight (in kg)								
Permissible gross weight	1995	2015/2005 ^{a)}	2010	2030	2100	2120	2155	2175
Unladen weight ready for work	1395	1415	1410	1430	1500	1520	1555	1575
Permissible trailer loads, trailer braked	1400 ^{b)} /1600 ^{c)} (1400 ^{b)} / ^{c)} ^{a)}				1600 ^{b)} /1700 ^{c)} (1600 ^{b)} / ^{c)} ^{a)}			
Permissible trailer loads, trailer unbraked	650							

^{a)} Vehicles of the group N1.

^{b)} Uphills up to 12 %

^{c)} Uphills up to 8 %

Engine 2.0 I/125 kW TDI CR - EU5

Output (kW per rpm)	Max. torque (Nm per rpm)		Number of cylinders/Displacement (cm ³)	
125/4200	350/1750 - 2500		4/1968	
Performances	OCTAVIA RS M6	OCTAVIA RS DQ6	ESTATE CAR RS M6	ESTATE CAR RS DQ6
Maximum speed (km/h)	226	224	225	223
Acceleration 0 - 100 km/h (s)	8.3	8.3	8.4	8.4
Fuel consumption (in ltr./100 km) and CO ₂ (in g/km)				
Urban	7.5	7.9	7.5	7.9
Non-urban	4.6	4.9	4.6	4.9
Combination	5.7	6.0	5.7	6.0
CO ₂ emission - combination	149	159	149	159
Weight (in kg)				
Permissible gross weight	1950/2015 ^{a)}	1970/2035 ^{a)}	1965/2030 ^{a)}	1985/2050 ^{a)}
Unladen weight ready for work	1470	1490	1485	1505
Permissible trailer loads, trailer braked	1400 ^{b)} /1600 ^{c)} (1400 ^{b)c)} ^{a)}			
Permissible trailer loads, trailer unbraked	650			

^{a)} Vehicles of the group N1.

^{b)} Uphills up to 12 %

^{c)} Uphills up to 8 %

Index

A

Abroad	173
ABS	164
Warning light	32
Accessories	204
Active driver-steering recommendation	163
Adjusting seats	64, 138
electrically	65
Adjusting the steering wheel	104
Air conditioning system	94
Air outlet vents	91
Recirculated air mode	97
Airbag	145
Deployment	145
Front airbag	146
Head airbag	150
Side airbag	148
Warning light	29
Airbag system	145
Warning light	29
Alarm	42
Alternator	
Warning light	33
Antilock brake system	164
Antilock brake system (ABS)	
Warning light	32
Anti-theft alarm system	42
Ashtray	79
Assigning the remote control key to the memory	
buttons	66
Auto Check Control	24
Auto Computer	18
Automatic driving lamp control	49
Automatic gearbox	114
Emergency programme	118
Kickdown	117
Selector lever-emergency unlocking	118
Tiptronic	117

Automatic seat adjustment	66
Automatic vehicle wash systems	177
Automatic wiper/washer system	58
Avoiding damage to your vehicle	173

B

Battery	33, 194
change	197
Charge	196
Operation in winter	196
Before setting off	137
Belt	
Warning light	32
Belt tensioners	144
Belts	141
Bonnet	14, 187
Warning light	32
Boot lid	39
Lighting	56
Warning light	32
Brake	
Handbrake	107
Warning light	33
Brake Assist	165
Brake booster	164
Brake fluid	193
Brakes	163
Bulbs	
Warning light	28
Button for the central locking system	38
Button in the driver's door	
Power windows	43

C

Car jack	206, 209
Car state	24

Catalytic converter	168
Central locking system	36
lock	38
unlock	38
Changes	204
Changing a wheel	207
Changing bulbs	220
Changing the engine oil	190
Changing wheels around	201
Charging the battery	196
Warning light	33
Check engine oil level	189
Child safety	153
Side airbag	155
Child safety lock	36
Child safety seat	
on the front passenger seat	154
Safety information	153
Child seat	155
Classification into groups	155
ISOFIX system	158
Children and safety	153
Chrome parts	179
Cigarette lighter	81
Cleaning	177
Climatronic	
Defrosting windows	100
Recirculated air mode	99
Climatronic (automatic air conditioning)	97
Clock	18
Clothes hooks	88
Cockpit	
General view	9
Compartments	81
Computer	18
Convenience operation	45
Converting/masking over headlights	173

Coolant	191
replenishing	192
Warning light	30
Coolant level	
Warning light	30
Coolant quantity	
Warning light	30
Coolant temperature gauge	16
Coolant temperature/coolant level	
Warning light	30
Cornering lights	50
Correct seated position	138
Counter for distance driven	16
Cruise control system	110
Warning light	28
Cup holder	
front	78
rear	79
D	
Dash panel insert	15
Daylight driving lights	48
Deactivating	
an airbag	151
Deactivating an airbag	151
Defrosting rear window	56
De-icing the windows	179
Diesel	185
Diesel engines	
Starting the engine	106
Diesel particle filter	167
Warning light	28
Digital clock	18
Direction indicators	54
Warning light	28
Display	22
Displays	15
Distance driven	16
Door	
Child safety lock	36

Driving economically	169
E	
EDL	162
Electric sliding/tilting roof	46
Electrically adjustable exterior mirror	62
Electronic Differential Lock	162
Electronic immobiliser	36
Electronic stability programme	161
Electronic stability programme (ESP)	
Warning light	31
Emergency wheel	206
Engine	
starting	105
switching off	106
Engine compartment	
Safety information	188
Engine electronics	
Warning light	30
Engine oil	189
Changing	190
changing	190
check	189
replenishing	190
Warning light	29
Engine oil level	
Warning light	34
Engine revolutions counter	15
Environment	169
Environmental compatibility	169, 172
ESP	161
Warning light	31
Exhaust gas	
Warning light	29
Exhaust gas inspection	
Warning light	29
Explanations	6
Exterior mirror	62
Exterior mirror heater	62

F

First-aid box	205
Fixing net	
Estate	73
Octavia	72
Fog lights	51
Indicator light	28
Warning light	28
Fog lights with the function CORNER	52
Foldable luggage compartment cover	75
Front airbag	146
Front armrest	85
Fuel	183
Diesel fuel	185
Fuel gauge	16
Petrol	183
Fuel consumption	169
Saving energy	169
Fuel gauge	16
Fuel reserve	
Warning light	34
Full wheel trim	208
Fuses	217

G

Gearbox	
mechanical	107
General view	
Cockpit	9
Glass roof	46
Glow plug system	106
Warning light	30
GSM	122, 128

H

Hand break	
Warning light	33
Handbrake	107

Hazard warning light system	53
Warning light	28
Head airbag	150
Head restraint	67
Headlamp range adjustment	53
Headlight cleaning system	59
Headlight flasher	54
Headlights	
Fog lights	51
Headlight cleaning system	59
Heated windscreen washer nozzles	58
Heating	92
Auxiliary heating (auxiliary heating)	100
Defrosting windows	93
Recirculated air mode	94
Height adjustment	143
Horn	9
I	
Ignition	104
Ignition lock	104
Immobiliser	36
Information display	22
Instrument cluster	15
Instrument lighting	52
Interior light	
Luggage compartment	56
Interior lighting	54
Interior mirror	61
Interior monitor	43
Intermittent wiping	58
Internet connection	135
ISOFIX	158
ISOFIX system	158
J	
Jacking points	209
Jump-starting	213

L

Lashing eyes	72
Leather care	181
Light	
automatic	49
Changing bulbs	220
Lights	
converting/masking over	173
Range adjustment	53
Warning lights	26
lights	
on and off	48
Liquid in reservoir for windscreen washer system	
Warning light	33
Loading	71
Lock	
Central locking system	38
Locking	36
Remote control	41
Locking and unlocking from inside	38
Low beam	48
Warning light	28
Luggage	39
Luggage compartment	39, 71
Fixing of the floor covering	74
Folding double hooks	73
Folding hooks	73
Lashing eyes	72
Luggage compartment - variable loading floor	75
Luggage compartment cover	74
Luggage rack	77

M

Main beam	48, 54
Warning light	28
Manual gearbox	107
Manual shifting of gears	107
Memory for the on-board computer	19

Mobile phone	122, 128
Connection to the hands-free system	129
Connection with the hands-free system	123
Voice control	134
Motoring abroad	173
Multifunction steering wheel	120
Multi-functional indicator	18
Multimedia	135
AUX-IN	135
CD changer	135
MDI	135

N

Net partition (Estate)	76
Note holder	79

O

Oil	189
Warning light	29
Oil dipstick	189
Onboard computer	18
Open door	
Warning light	33
Opening a single door	36
Opening for skis	86
Operation in winter	
Battery	196
Biodiesel	185
De-icing windows	179
Outside temperature	20
Overview of the engine compartment	189

P

Paint	179
Paint damage	179
Parking	108

- Parking aid
 - Front and rear 109
 - rear 108
 - Parking light 50
 - Parking the vehicle 108
 - Passive Safety 137
 - Payload 227
 - Pedals 70
 - Petrol 183
 - Petrol engines
 - Starting the engine 106
 - Polishing 179
 - Power socket 81
 - Power steering 165
 - Warning light 29
 - Power windows 43
 - Button in the driver's door 43
 - Button in the front passenger door and in the rear doors 44
 - Operational faults 45
 - with central locking system 45
- ## R
- Radiator fan 193
 - Rear armrest 70, 86
 - Rear fog light 52
 - Warning light 28
 - Rear seats 68
 - Rear window
 - heater 56
 - Rear window heater 56
 - Rear-view mirror
 - Exterior mirror 62
 - Interior mirror 61
 - Recharge battery 196
 - Recommendation for changing gears 18
 - Refuelling 185
 - Remote control 41
 - Synchronisation 42
 - Removing the seats 69
 - Replacement of parts 204
 - Replacing fuses 217
 - Replacing the wiper blades 60
 - Roof aerial 177
 - Running in the vehicle 168
- ## S
- Safe securing 37
 - Safety 137
 - Safety information
 - Engine compartment 188
 - Safety wheel bolts 210
 - Saving electrical energy 169
 - Seat belt height adjuster
 - Seat belts 143
 - Seat belt warning light 143
 - Seat belts 141
 - Belt tensioners 144
 - Cleaning 182
 - fastening 143
 - Safety information 142
 - taking off 144
 - Warning light 32
 - Seat heaters 70
 - Selector lever 115
 - Selector lever lock
 - Warning light 31
 - Selector lever positions 115
 - Selector lever-emergency unlocking 118
 - Service reminder indicator 17
 - Setting temperature
 - Heating 92
 - Setting the clock 18
 - Shifting 107
 - Side airbag 148
 - Side lights 48
 - Snow chains 203
 - Spare wheel 206
 - Speedometer 16
 - Stability system 161
 - START STOP 214
 - Starting the engine 105
 - after fuel tank has run empty 106
 - Diesel engines 106
 - Petrol engines 106
 - START-STOP 111
 - Steering
 - active driver-steering recommendation ... 163
 - Steering force assistance 165
 - Storage compartment
 - Lighting 55
 - Storage compartments 81
 - Storage facilities 81
 - Sun 57
 - Sun screen 57
 - Switch off the Traction control system (TCS)
 - Warning light 31
 - Switching off the engine 106
- ## T
- Taking care of your vehicle 177
 - TCS 162
 - Warning light 31
 - Technical data 227
 - Telephone 122, 128
 - Temperature
 - outside 20
 - The first 1 500 kilometres 168
 - The roof luggage rack system 77
 - Through-loading bag 87
 - Tilting roof 46
 - Tiptronic 114
 - Tool 206
 - Top Tether 158
 - Towing 214
 - Towing a trailer 175
 - Traction control system (TCS) 162
 - Warning light 31
 - Trailer 175
 - General Maintenance 175

Transporting children safely	153
Tread depth	200
Turn signal lights	54
Warning light	28
Two-way radio systems	122
Tyre	199
Tyre inflation pressure	
Warning light	31
Tyre repair kit	
Tyre repair	210
Tyres	
Winter tyres	202

U

Underbody protection	180
unlock	
Central locking system	38
Unlocking	36
Remote control	41
Uphill Start Assist	165

V

Vanity mirror	57
Vehicle key	35
Vehicle tool kit	206
Ventilation	
Auxiliary ventilation	100
Visors	57

W

Warning lights	26
Warning symbols	26
Warning triangle	205
Washing	177
with a high-pressure cleaner	178
Washing the vehicle	177
Washing vehicle by hand	178
Wax treatment	178

Weight	227
Wheel	
Changing	207
Spare	206
Wheel bolts	202
Wheel trim	199, 208
Wheels	199
Windows	43
de-icing	179
Windscreen washer nozzles	58
Windshield washer fluid reservoir	197
Warning light	33
Windshield washer system	197
Windshield wiper	58
Winter tyres	202
Wiper blades	
Replacing the wiper blades	60

X

XDL	162
Xenon headlights	220

Škoda Auto pursues a policy of constant product and model development. We trust that you will understand that changes to models in terms of shape, equipment and engineering, may be introduced at any time. The information about scope of delivery, appearance, performances, dimensions, weight, fuel consumption, standards and functions of the vehicle is only correct at the time of publication. Certain items of equipment might only be installed later on (information given by the local authorised Škoda Service Partner) and only envisaged for particular markets. It is therefore not possible for legal claims to be made based on the data, illustrations and descriptions contained in this Owner's Manual.

Reprinting, reproduction or translation, either in whole or in part, is not permitted without the written consent of Škoda Auto.

Škoda Auto expressly reserves all rights relating to copyright laws.

We reserve the right to make changes to this document.

Issued by: ŠKODA AUTO a.s.

© ŠKODA AUTO a.s. 2011

Minimisation of fuel consumption and CO₂ emissions

- Start-stop system*
- Recovery*
- Indication of recommended gear*

Weight reduction

- Optimisation of high-strength panels, reduction of thickness in panels and other materials
- Replacement of spare wheel with tyre repair kit

Reduction of energy consumption

- Use of energy-saving electromechanical steering instead of hydraulic type
- Optimisation of efficiency of generators
- Optimisation of operating consumption and electrical current consumption

Optimisation of aerodynamic- and rolling resistance

- Additional aerodynamic spoilers*
- Additional covers at rack (CD covers)*
- Optimised cooling (input grid, additional seal)*
- Reduction by 15 mm* with frame
- Ro-Wi tyres (wheels with low rolling resistance)*



* realised in the Greenline 2 series

Recyclability

- All models currently in production homologized in conformity with the requirements for recyclability (EU Directive 2005/64/EC)
- Use of recyclable, environmentally-friendly materials
- Use of recycled materials with the parameters of the new material preferred
- Labelling of materials for the purpose of making sorting easy



How you can contribute to a cleaner environment

The fuel consumption of your Škoda - and thus the level of pollutants contained in the exhaust - is also determined by how you drive.

The noise level and wear and tear are also influenced by how you personally handle your vehicle.

This Owner's Manual tells you how to drive your Škoda to achieve the minimum impact on the environment, and how to save money at the same time. Look up „Environment“ in the Index to find out more.

Please also refer to all the texts identified with a  in this Owner's Manual.

Make your contribution - for the sake of the environment.

www.skoda-auto.com

Návod k obsluze
Octavia anglicky 05.11
S64.5610.08.20
1Z0 012 003 PJ