

OWNER'S MANUAL

Vehicle and Infotainment

ŠKODA SUPERB



ŠKODA



Documentation of vehicle delivery

Date vehicle handover^{a)}

			/				/					
--	--	--	---	--	--	--	---	--	--	--	--	--

ŠKODA Partner

Stamp and signature of the vendor

I confirm that I have taken delivery of the vehicle in good condition, have received information on how to operate it correctly, and have had the terms of the warranty explained to me.

Signature of the customer

Has the vehicle an extended warranty? Yes No

Limitations of the ŠKODA extended warranty^{b)}

Years: _____ or km/mile-
age: _____
or
Miles: _____

^{a)} Due to the requirements of generally binding country-specific regulations, the date of first registration can be specified instead of the date the vehicle hand-over.

^{b)} Depending on which comes first.



3V0012720AJ

1. Vehicle owner

This vehicle with the official registration number
(To be filled in by the vendor)
belongs to:

Title, Name / Company:

Address:

Telephone:

ŠKODA partner

Service consultant:

Telephone:

2. Vehicle owner

This vehicle with the official registration number
belongs to:

Title, Name / Company:

Address:

Telephone:

ŠKODA partner

Service consultant:

Telephone:



3V001Z720AJ

Useful links

Before starting off

- Adjusting the seat » page 83
- Adjusting the steering wheel » page 21
- Exterior mirrors » page 82
- Headlights/lights » page 70
- Windscreen wipers and washers » page 80
- Heating and ventilation » page 117
- Heated windscreen » page 77

Instrument cluster

- Warning lights » page 39
- Display operation » page 51
- Set the time » page 49

Unlocking and opening

- Keyless unlocking (KESSY) » page 59
- Luggage compartment lid » page 63
- Power windows » page 66
- Bonnet » page 270

Connectivity

- Online Services – ŠKODA Connect » page 13
- SmartLink+ » page 175
- Connecting Infotainment to the Internet » page 172
- Hotspot (WLAN) » page 173
- Making telephone calls » page 161
- Configuration wizard » page 132

Driving

- Automatic gearbox » page 212
- Braking and stabilizing systems » page 217
- START-STOP system » page 206

- Adaptive cruise control » page 236
- Lane Assist » page 247

Parking

- Electric parking brake » page 208
- Parking the vehicle » page 210
- Parking aid » page 219
- Reversing camera » page 226

Care and maintenance

- Service intervals » page 54
- Tyre pressure » page 277
- Washing the vehicle » page 261
- Folding the windscreen wiper arms securely » page 294

Inspecting and replenishing

- Refuelling » page 265
- AdBlue® » page 267
- Engine oil » page 271
- Windscreen washer fluid » page 271

Emergencies

- Emergency call » page 16
- Vehicle tool kit » page 282
- Lamp replacement » page 300
- Replacing fuses » page 296
- Changing a wheel » page 283
- Jump-starting » page 288
- Towing the vehicle » page 289

Interesting tips

- Electronic version of the Owner's Manual » page 10
- Tutorial videos » page 11
- Digital instrument panel » page 37

Table of Contents

Liability for defects and ŠKODA Warranty for new cars	6
--	---

Accident data recorder (Event Data Recorder)	8
---	---

Radio equipment - Information on Directive 2014/53/EU	9
--	---

About the Owner's Manual

Introductory information	10
General	10
Printed Owner's Manual	10
Electronic version of the Owner's Manual	10
Tutorial videos	11
Application MyŠKODA App	11
Notes	12

Online Services

ŠKODA Connect	13
Service package "ŠKODA Connect"	13
"ŠKODA Connect" website	13
User and vehicle registration, activation of online services	13
Managing online services	15
Emergency call	16
"Care Connect" Services	17
"Infotainment Online" services	18

Safety

Passive Safety	19
General information	19
Correct and safe seating position	19

Seat belts	22
Using seat belts	22
Inertia reel and belt tensioners	24

Airbag system	25
Description of the airbag system	25
Airbag deactivation	27

Transporting children safely	29
Child seat	29
Fastening systems	32

Using the system

Cockpit	35
Overview	34

Instruments and warning lights	36
Instrument cluster	36
Digital instrument cluster	37
Warning lights	39

Information system	48
Driver information system	48
Operation of the information system	51
Driving data (Multifunction display)	51
Menus in the display of the instrument cluster	53
Service intervals	54
Personalization	55

Unlocking and opening	57
Unlocking and locking	57
Anti-theft alarm system	62
Manually operated tailgate	63
Electric boot lid	64
Window operation	66
Panoramic tilting / sliding sunroof	68

Lights and visibility	70
Light	70
Headlight Assist (Light Assist / Dynamic Light Assist)	74
Interior lighting	75
Visibility	77
Windscreen wipers and washers	79
Rear view mirror	81

Seats and head restraints	83
Front seats	83
Rear seats	87
Headrests	88
Seat heating and ventilation	89
Heated steering wheel	91

Practical features	92
Passenger compartment features	92
Electrical sockets	100
Ashtray and cigarette lighter	102
Tablet holder	103

Transport of cargo	105
Luggage compartment	105
Variable loading floor in the luggage compartment (Estate)	113
Net partition	115
Transportation on the roof rack	116

Heating and ventilation	117
Heating, manual air conditioning system, Climatronic	117
Auxiliary heating (auxiliary heating and ventilation)	122

Infotainment

Introductory information	125
Important information	125
Infotainment Overview	125

Infotainment operation	128
Infotainment operation	128
Voice control	133
Updating the Infotainment software	135
Infotainment settings - Columbus, Amundsen, Bolero	136
Infotainment system settings	136
Menu Settings Radio	139
Media menu settings	140
Image menu settings	140
Video DVD menu settings	140
Settings	140
SmartLink+ menu settings	141
Navigation menu settings	142
Infotainment settings - Swing	144
Infotainment system settings	144
Radio menu settings	145
Media menu settings	146
Import contacts Telephone menu settings	146
SmartLink+ menu settings	146
Radio	147
service	147
Media	150
service	150
Audio sources	152
Images	156
Image viewer	156
Video DVD	158
video player	158
Media Command	159
Operation	159

Telephone	161
Introductory information	161
Pairing and connecting	163
Use the SIM card in the external module	166
Telephone functions	167
Text messages (SMS)	170
Data connection	172
Internet connection	172
Connecting via the CarStick device	172
Establishing a connection using a SIM card in the external module	173
Establishing a connection using the Bluetooth® rSAP profile	173
Connecting via WLAN	173
SmartLink	175
Introductory information	175
Android Auto	176
Apple CarPlay	177
MirrorLink®	178
Application "ŠKODA OneApp"	179
Navigation	180
Introductory information	180
Search for destination and enter	183
Saved destinations	186
Import your own goals	188
Map	190
Route guidance	193
Route	196
Waypoint mode	198
Traffic reports	200
vehicle systems	202
CAR - Vehicle settings	202

Driving

Starting-off and Driving	204
Starting and stopping the engine	204
START-STOPsystem	206
Brakes and Parking	208
Manual gear changing and pedals	211
Automatic transmission	211
Running in the engine and economical driving	214
Avoiding damage to your vehicle	215
Assist systems	216
General information	216
Braking and stabilisation systems	217
Parking aid (ParkPilot)	219
Rear traffic alert and wizard for "Blind spot" Monitoring	223
Rear View Camera	226
Park Assist	229
Cruise Control System	234
Speed limiter	235
Adaptive Cruise Control (ACC)	236
Front Assist	242
Select the driving mode (Driving Mode Selection)	244
Proactive occupant protection (Crew Protect Assist)	246
Spurhalteassistent (Lane Assist)	247
Traffic jam assistant	249
Assistant for emergencies	249
Traffic sign recognition	250
Fatigue detection system	252
Tyre pressure monitoring	252
Towing device and trailer	254
Hitch	254
Using hitch	255

General Maintenance

Care and maintenance	259
Service work, adjustments and technical alterations	259
Cleaning and care	260
Inspecting and replenishing	265
Fuel	265
AdBlue® and its refilling	267
Engine compartment	269
Engine oil	271
Coolant	272
Brake fluid	273
Vehicle battery	274
Wheels	276
Wheels and tyres	276
Operating in winter conditions	279

Do-it-yourself

Emergency equipment and self-help	281
Emergency equipment	281
Changing a wheel	283
Puncture repair kit	286
Jump-starting	288
Towing the vehicle	289
Remote control and removable light - changing the battery	291
Emergency unlocking / unlocking of doors	293
Replacing windscreen wiper blades	294
Fuses and light bulbs	296
Fuses	296
Bulbs	300

Technical data

Technical data	304
Basic vehicle data	304
Vehicle-specific details per engine type	309

Index

Liability for defects and ŠKODA Warranty for new cars

Materials defect liability

Your ŠKODA Partner, as a vendor, is liable to you for material damage to your new ŠKODA car, ŠKODA Genuine Parts or ŠKODA Genuine Accessories in accordance with statutory regulations and the purchase agreement.

ŠKODA warranty for new cars

As well as the materials defect liability, ŠKODA AUTO a.s. grants you the ŠKODA warranty for new cars (hereinafter referred to as "ŠKODA warranty"),¹⁾ according to the conditions described below.

As part of the ŠKODA warranty, ŠKODA AUTO will ensure the following services.

- ▶ Free repair of faulty components or vehicle defects that occur within two years from the start of the ŠKODA warranty.
- ▶ Free repair of paintwork defects on your vehicle that occur within three years from the start of the ŠKODA warranty.
- ▶ Free repair of rust perforation to the bodywork of your vehicle that occurs within twelve years from the start of the warranty. Only rust perforation of body panels from the inside to the outside is included in the definition of rust perforation on bodywork and covered by the ŠKODA warranty.

The start of warranty is the date on which the first buyer purchases the new cars from the ŠKODA Partner¹⁾. The ŠKODA Partner must insert this date into the manufacturer's systems accordingly for your car identified by the Vehicle Identification Number.

Vehicle repairs may be carried out either by replacing the faulty part or by repairing it. Replaced parts become the property of the ŠKODA Service Partner.

There shall be no further claims arising from the ŠKODA warranty. In particular, there shall be no claims for replacement, cancellation, provision of a courtesy vehicle for the duration of repairs or compensation for damages.

The ŠKODA warranty is valid at any ŠKODA service partner.

¹⁾ Due to the requirements of generally binding country-specific regulations, the date of first registration can be specified instead of the date the vehicle handover.

One of the conditions for service from the ŠKODA warranty is that all service work has been carried out in a timely and adequate manner and in accordance with ŠKODA AUTO provisions. It must be proven that service work has been carried out properly and in accordance with the ŠKODA AUTO provisions when raising a claim from the ŠKODA warranty. In the event of a missed service or failure to carry out a service according to the ŠKODA AUTO provisions, you may still be entitled to warranty claims as long as you can prove that the missed service or the failure to carry out a service according to the ŠKODA AUTO provisions was not the cause of the defect.

ŠKODA warranty excludes parts that are subject to natural wear such as tyres, spark plugs, wiper blades, brake pads and brake discs, clutch, bulbs, synchroniser rings, batteries etc. The ŠKODA warranty also does not cover faults to bodywork, installations or conversions provided by third-parties, or vehicle faults caused as a result. The same applies to accessories that are not factory installed and/or delivered.

In addition, this warranty does not apply if the defect was caused by one of the following:

- ▶ Unauthorized use, improper handling (e.g. use in racing competitions or overloading), improper care and maintenance or unapproved modification to your vehicle.
- ▶ Non-compliance with provisions in the Owner's Manual or other factory-supplied instructions.
- ▶ External causes or influences (e.g. accidents, hail, flooding etc.).
- ▶ Parts fitted or connected on or in the vehicle whose use has not been approved by ŠKODA AUTO, or modification of the vehicle in a manner not approved by ŠKODA AUTO (e.g. tuning).
- ▶ Damage caused by you that was not immediately seen to by a specialist garage or was not rectified properly.

It is the customer's responsibility to prove that it was not the cause.

This ŠKODA warranty does not affect the purchaser's statutory rights from materials defect liability from the vehicle vendor and other potential claims from product liability laws. ▶

Mobility warranty

The mobility warranty provides a sense of security when travelling in your vehicle.

As part of the mobility warranty, if your car breaks down as a result of an unexpected fault when you are on the move, you can access services to ensure your continued mobility. These services include the following: Breakdown service at the breakdown location and towing to the ŠKODA Service Partner, technical assistance by phone or on-site operation.

If your vehicle is not repaired on the same day, the ŠKODA Service Partner may provide further services as required, such as replacement transportation (bus, train etc.) or a courtesy vehicle etc.

More information regarding terms and conditions for the provision of a mobility warranty for your vehicle can be obtained from your ŠKODA Partner. They will also provide you with detailed terms and conditions for the mobility warranty with respect to your vehicle. In the event that there is no mobility warranty coverage available for your vehicle, you should check with any ŠKODA Service Partner about the possibility of a subsequent agreement.

Optional ŠKODA extended warranty

If you opted for a ŠKODA extended warranty when purchasing your new car, the two-year ŠKODA warranty with regards to all free warranty repairs is extended by the period you chose or until the chosen mileage limit has been reached, whichever occurs first.

The previously mentioned paint warranty and the warranty against rust perforation are unaffected by the ŠKODA extended warranty.

The ŠKODA extended warranty does not apply to external and internal foils.

The information on the detailed conditions of the ŠKODA extended warranty is provided by your ŠKODA partner.

i Note

The ŠKODA extended warranty is only available in some countries.

Accident data recorder (Event Data Recorder)

The vehicle is equipped with a device that serves as an accident data recorder (referred to solely as “EDR” from this point). The main purpose of the EDR is data recording during a traffic accident or other exceptional traffic conditions (referred to solely as “accident” from this point), where the restraint systems are activated.

The EDR records the accident in a short time (approximately 10 s), by showing the following information, for example:

- ▶ The function of certain vehicle systems,
- ▶ The driver and passenger seat belt status,
- ▶ The actuation of the brake and accelerator pedal,
- ▶ The speed of the vehicle at the time of the accident.

The recorded data helps with the analysis of how the vehicle systems were behaving shortly before, during and shortly after the accident, thereby ensuring better information regarding the circumstances under which the accident occurred, which lead to material damage and possibly to personal injury.

The data relating to assist systems in the vehicle is then also recorded. In addition to the information on whether the affected systems were switched on or off at the relevant time, whether these were only partially available or were inactive, there is also the possibility of tracking whether these vehicle functions controlled, accelerated or braked the vehicle during the accident. Depending on the vehicle equipment, these functions may include, for example:

- ▶ Adaptive Cruise Control (ACC)
- ▶ Lane Assist
- ▶ Park Assist
- ▶ Parking aid
- ▶ Emergency brake function (Front Assist)

EDR data is only recorded if an accident causes the restraint systems to be activated. Under normal driving conditions there is no data recording and there is no audio or video recording of the vehicle interior or the vehicle environment. Personal data such as name, gender, age or place where the accident occurred is also not stored in the EDR. However, third parties such as law enforcement authorities may use certain resources to connect EDR content to other data sources, and therefore deduce the identification of some of the people involved in the accident when investigating the causes of the accident.

Reading out the EDR requires special equipment with specific access authorization and a legally prescribed diagnostic connection in the vehicle (“on-board diagnostics”), and the ignition will need to be switched on.

ŠKODA AUTO will not read or otherwise process any accident data from the EDR without the approval of the vehicle owner or other person authorised for use of the vehicle. Exceptions are specified in the contractual arrangements, or these are subject to generally binding regulations.

Due to the legal requirements, ŠKODA AUTO is required to monitor the quality and safety of its products, meaning that it is only entitled to use data from the EDR for monitoring the product on the market, for further research and development, and to improve the quality of the vehicle's safety systems. For the purpose of research and development, ŠKODA AUTO will also make data available to third parties. This is done exclusively in anonymous form, i.e. without any connection to the specific vehicle, the vehicle owner or other authorised user.



Your vehicle has various radio systems.

The manufacturers of these radio systems declare that these systems comply with the requirements of Directive 2014/53/EU.

To display **Information on Directive 2014/53 / EU and the Declaration of Conformity** proceed as follows.

1. Scan the QR code » Fig. 1 or enter the following address in your web browser.
<http://go.skoda.eu/owners-manuals>
2. Click on "Choose your manual".
3. Select the desired model - a menu with the manuals is displayed.
4. Select the construction period as well as the language.
5. Select the **Information on Directive 2014/53 / EU** file in **pdf** format.

About the Owner's Manual

Introductory information

General

Read this Owner's Manual carefully, because the operation in accordance with these instructions is a prerequisite for proper use of the vehicle.

When using the vehicle, the universally applicable country-specific legal requirements (e.g. for transporting children, deactivating the airbag, tyre use, road traffic etc.) must always be observed.

Always pay attention when driving! As the driver, you are fully responsible for road safety.

The Owner's Manual applies to all **body variants** of the vehicle, all related **model versions** as well as all **equipment levels**.

The Owner's Manual describes **all possible equipment variants** without identifying them as special equipment, model variants or market-dependent equipment. Consequently, this vehicle **does not contain all of the equipment components** described in the Owner's Manual.

The level of equipment in your vehicle refers to your purchase contract for the vehicle. For any questions regarding the scope of equipment, please contact a ŠKODA Partner.

The **pictures** in the Owner's Manual are for illustrative purposes only. The illustrations can differ in minor details from your vehicle; they are only intended to provide general information.

ŠKODA AUTO pursues a policy of ongoing product and model development with all vehicles. Changes in terms of supply scope are possible at any time with regard to design, equipment and technology. The information listed in the Owner's Manual corresponds to the information available at the time of going to press.

Therefore legal claims cannot be made based on the technical data, illustrations and information contained in the Owner's Manual.

We recommend that the **web pages** that are referred to in the Owner's Manual are displayed using the classic view. If the web pages are displayed using the mobile view, they may not contain all necessary information.

Printed Owner's Manual

The printed Owner's Manual includes the most important information relating to vehicle operation. For complete information, see the electronic version of the Owner's Manual.

Electronic version of the Owner's Manual



Fig. 2
ŠKODA websites

The electronic version of the Owner's Manual includes full information regarding vehicle operation.

The electronic version of the Owner's Manual is available on the ŠKODA website and in the MyŠKODA App mobile application.

Displaying the electronic version of the Owner's Manual

› Scan the QR code » Fig. 2 or enter the following address in your web browser.

<http://go.skoda.eu/owners-manuals>

- › Click on "Choose your manual".
- › Select the desired model.
- › Select the construction period as well as the language.
- › Select the desired Owner's Manual.

Tutorial videos

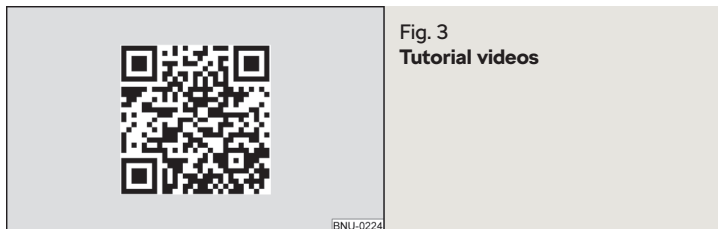

The operation of some vehicle functions can be displayed in the form of video instructions.

Show menu with video instructions

› Scan the QR code » Fig. 3 or enter the following address in your web browser.

<http://go.skoda.eu/owners-manuals-videos>

Note

The video instructions are only available in some language versions.

Application MyŠKODA App

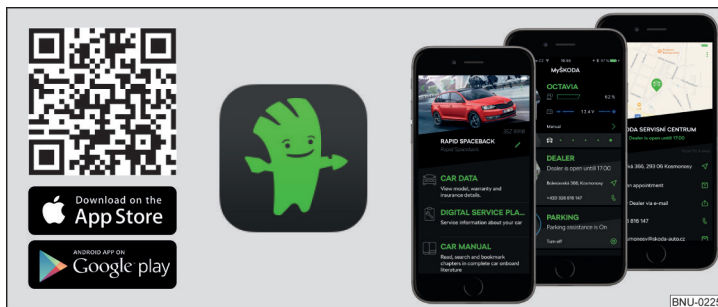

Fig. 4 The MyŠKODA App application is available for devices with the Android (Google) or iOS (Apple) operating system.

The MyŠKODA App application contains, for example, the electronic version of the Owner's Manual, quick tips regarding how to resolve certain situations in relation to the vehicle or a description of the Simply Clever solutions.

You can use this application to get in touch with a ŠKODA partner and to use its services or to access the breakdown service quickly.

The application can also be used as an RSS reader of favourite websites.

After entering the following address into the web browser, the website is opened with information on the ŠKODA mobile applications.

<http://go.skoda.eu/service-app>

Installing the MyŠKODA App application

› Scan the QR code » Fig. 4 .

Notes

Terms used

“Specialist” - Workshop - a workshop that carries out specialist service tasks for ŠKODA vehicles. A specialist can be a ŠKODA Partner, a ŠKODA Service Partner, or an independent workshop.

“ŠKODA service partners” - A workshop that has been contractually authorised by ŠKODA AUTO or its distribution partner to perform service work on ŠKODA vehicles and to sell ŠKODA Genuine Parts.

“ŠKODA partners” - A company that has been authorised by ŠKODA AUTO or its distribution partner to sell new ŠKODA vehicles and, when applicable, to service them using ŠKODA Genuine Parts and sell ŠKODA Genuine Parts.

Text notes

“Press” - Short press (e.g. a button) within 1 s

“Hold” - Long press (e.g. a button) for more than 1 s

Direction indications

All direction indications such as “left”, “right”, “front”, “rear” relate to the forward direction of travel of the vehicle.

Explanation of symbols

→ Marker to the next operation step

WARNING

Texts with this symbol draw attention to threats of a **serious accident, injury or loss of life**.

CAUTION

Texts with this symbol draw attention to the risk of vehicle damage or possible inoperability of some systems.

Note

Texts with this symbol contain additional information.

Online Services

ŠKODA Connect

Service package “ŠKODA Connect”

The “ŠKODA Connect” online services extend the vehicle and Infotainment functions with the “Care Connect” and “Infotainment Online” service packages.

“ŠKODA Connect” online services are not included in the vehicle delivery. Their order is made separately via the website “ŠKODA Connect Portal” » [page 13, Website “ŠKODA Connect Portal”](#). Rights and obligations of the Parties with respect to the provision of these services are governed by a separate agreement.

“Care Connect” online services

“Care Connect” services include the following features.

- ▶ Emergency, information and breakdown call.
- ▶ Proactive service offering to connect with your ŠKODA service partner.
- ▶ Remote access to the vehicle using the “ŠKODA Connect” application and the “ŠKODA Connect Portal” website.

For “Care Connect” Services functionality, the vehicle must be within range of a mobile network through which the “Care Connect” Services are provided.

“Infotainment Online” online services

The “Infotainment Online” services extend the Infotainment functions, e.g. with the following functions.

- ▶ Weather forecast.
- ▶ Filling station search with information on fuel prices.
- ▶ Online traffic information.
- ▶ Online destination search.

The Infotainment must be connected to the Internet for the “Infotainment Online” Services to work » [page 172](#).

Terms of use and availability of services

Current “**conditions for the use of the user account**” incl. “**declaration on the protection of personal data**” can be found on the “ŠKODA Connect Portal” website » [page 13, Website “ŠKODA Connect Portal”](#).

The availability of the services is dependent on the type of vehicle and on the type of Infotainment system installed in the vehicle. Some services are available only in certain countries.

i Note

The availability of the services listed always refers to the period of validity of the contract. During this interim period of validity, content changes of these services are possible.

“ŠKODA Connect” website



Fig. 5 Starting the ŠKODA Connect website

The “ŠKODA Connect” website contains information about the online services and their functions, access to the “ŠKODA Connect Portal” website, as well as the option to download the “ŠKODA Connect” application.

The “ŠKODA Connect” website can be opened by scanning the QR code » [Fig. 5](#) or by entering the following address in your web browser.

<http://go.skoda.eu/connectivity>

User and vehicle registration, activation of online services

Website “ŠKODA Connect Portal”



Fig. 6 Starting the ŠKODA Connect Portal website

The use of the “ŠKODA Connect” online services requires prior user and vehicle registration on the “ŠKODA Connect Portal” website as well as activation of online services in the Infotainment system.

The “ŠKODA Connect Portal” website can be opened by scanning the QR code » Fig. 6 or by entering the following address in your web browser.

<http://go.skoda.eu/connect-portal>

Information on registering for and activating online services



Fig. 7 Instructional video on registration and activation of services



Fig. 8 Electronic version of the instructions for registration and activation of services

Instructional video on registration and activation of services

Registration and activation are carried out in accordance with the instruction video.

The instruction video can be opened by scanning the QR code » Fig. 7 or entering the following address into the web browser.

<http://go.skoda.eu/connect-video>

Electronic version of the instructions for registration and activation of services

Current information on **registration and activation** of Online Services can be found in the **electronic version** of the instructions for the Online Services on the “ŠKODA Connect” website.

The electronic version of the instructions can be opened by scanning the QR code » Fig. 8 or by entering the following address in the web browser.

<http://go.skoda.eu/connect-manual>

i Note

For help with registration, activation as well as the Internet connection, please contact a ŠKODA service partner.

Activation in Infotainment

- › Turn on the ignition and switch on Infotainment.
- › Tap the **MENU** sensor field and then the function surface → **ŠKODA Connect (Online Services)** → **Registration**.
- › Enter and confirm the registration PIN code received during user and vehicle registration on the “ŠKODA Connect Portal” website.
- › Wait until the message **Registration complete.** is displayed (can take several minutes)
- › Confirm the message.

i Note

- Availability of a GPS signal and a mobile network is required for activation.
- In vehicles that only have “Infotainment Online” Services, a GPS signal must be available and the Infotainment must be connected to the Internet for activation.
- The list of services can be displayed » [page 15, Display of service management](#).

Deleting/switching the vehicle user

Deleting the user

- › Turn on the ignition and switch on Infotainment.
- › Tap the **MENU** sensor field and then the function surface → **ŠKODA Connect (Online Services)** → **Registration**.
- › Tap the function surface **Delete owner** → **Delete** and confirm the delete process. ▶

Changing the user

- › Turn on the ignition and switch on Infotainment.
- › Tap the **[MENU]** sensor field and then the function surface  → ŠKODA Connect (Online Services) → Registration.
- › Tap the function surface **New owner** → Transfer ownership.
- › Enter and confirm the registration PIN code received during registration of the new user and during vehicle registration on the ŠKODA Connect Portal website.
- › If necessary, confirm the change of user by tapping the function surface **Change main users**.

i Note

By deleting the registered vehicle in the user account on the “ŠKODA Connect Portal” website, the user is also deleted in the Infotainment system.

Managing online services

Display of service management

In Services Management, it is possible to display information about the online services, the validity of their license, or to switch the services on/off.

- › Turn on the ignition and switch on Infotainment.
- › Tap the **[MENU]** sensor field and then the function surface  → ŠKODA Connect (online services) → Services Management.
- › To **display the designations and the status of the services**, select the desired service.
- › For **detailed information about the service** tap the function surface **>**.
- › To **switch the services on/off**, tap the function surface with “Checkbox”.

Switch online services on/off in infotainment

Switching Private mode function on/off

By switching the **Private mode** function on, the services relating to sending vehicle information and personal data, which are essential for the provision of services, are deactivated.

- › Tap the **[MENU]** sensor field and then the function surface  → ŠKODA Connect (online services) → Services Management → Private mode.

Switching “Care Connect” services on/off

By switching the “Care Connect” services off, the services relating to sending vehicle information and personal data, which are essential for the provision of services, are deactivated.

- › Tap the **[MENU]** sensor field and then the function surface  → ŠKODA Connect (online services) → Services Management → Care Connect.

Switching “Infotainment Online” services on/off

- › Tap the **[MENU]** sensor field and then the function surface  → ŠKODA Connect (online services) → Services Management → Infotainment Online.

i Note

The **emergency call** remains fully functional after activation of the **Private mode** function or after deactivation of “Care Connect” services. The functions of the **information and breakdown call** are limited.

Online services at ŠKODA Switch service partner off/on

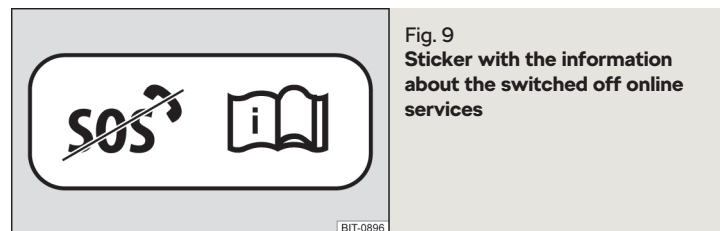

Fig. 9
Sticker with the information about the switched off online services

It is possible to have the online services switched off/on exclusively by a ŠKODA service partner.

After turning off the online services, none of the “ŠKODA Connect” online services are functioning.

To inform the vehicle user that the “ŠKODA Connect” online services, including the emergency call are out of order, the service partner **applies the sticker** » **Fig. 9** at a visible point in the vehicle (eg at the roof cladding). This **Sticker should not be removed** for as long as the online services are off. ▶

! CAUTION

It should be noted that the emergency, information and panning call is not available after switching off the online services. For this reason, no automatic emergency call is made in the event of a serious car accident.

Status Symbols of Online Services



Fig. 10
Status symbols of online services

In the Infotainment » Fig. 10 status line, information on the status of the Online Services is displayed.

- A** The “ŠKODA Connect” online services are available. At the same time the symbol of the connected network type can be displayed.
- B** The connection to the “ŠKODA Connect” online services is being established.
- C** Localisation services are restricted or disabled. Detailed information about online services can be displayed » page 15, *Display of service management*.
- D** Localisation services are enabled. Detailed information about online services can be displayed » page 15, *Display of service management*.

localisation services

For the complete functionality of some online services, activated localisation services are required.

Localisation services include, for example, information on the last parking position, area notification or speed notification.

When localisation services are active, one of the following symbols will be displayed in the status line in the Infotainment screen **D** » Fig. 10.

Emergency call

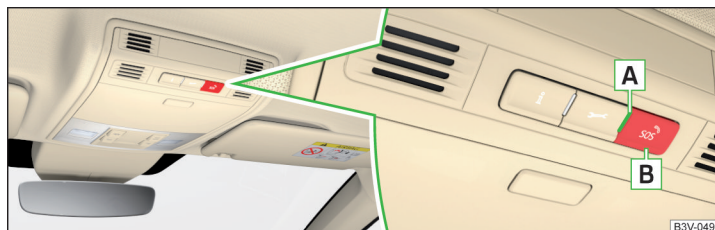

Fig. 11 Emergency call button

Serious accident

In the event of an accident with an air bag or belt tensioner release, a call to the emergency call centre is **automatically** started. The emergency call centre simultaneously receives information on the accident, e.g. the location and severity of the accident, the number of occupants with fastened seatbelts and the vehicle identification number (VIN).

Minor accident

The option for establishing a connection to the emergency call centre or to the breakdown service appears in the Infotainment screen.

Manual start of a call with the emergency call centre

- » Press and hold the **B** » Fig. 11 button.
- » In the Infotainment screen or on the instrument cluster display, confirm the connection setup.

The call can be started manually, for example, if you are reporting an accident in which you were not directly involved.

The **system status** is displayed after the ignition is switched on, by the illumination of warning lamp **A** » Fig. 11.

- ▶ Green - the system is functional.
- ▶ Red - there is a fault in the system.
- ▶ Not illuminated - the system is switched off » page 15.

i Note

The emergency service is functional even without user registration and activation of services.

“Care Connect” Services

Proactive service

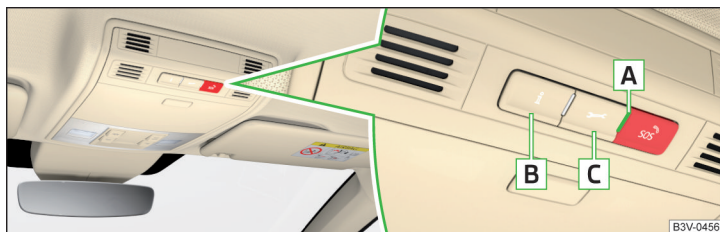

Fig. 12 Buttons and warning lights of the Care Connect services

The **proactive service** provides an overview of the technical status of your vehicle and on any due service events. It is also possible to establish a connection to the information or breakdown call centre.

Buttons and warning lights of “Care Connect” services » Fig. 12

- A** Warning light for system status.
- B** Press this button to establish a call to the **information number** in the event of problems with the online services or for information regarding the products and services of the ŠKODA brand.
- C** Press this button to establish a call to the **breakdown number** in the event of a breakdown.

The **system status** is displayed after the ignition is switched on, by the illumination of warning lamp **A** » Fig. 12.

- ▶ Green - the system is functional.
- ▶ Red - there is a fault in the system.

i Note

The availability of the services listed always refers to the period of validity of the contract. During this interim period of validity, content changes of these services are possible. Current information can be found on the “ŠKODA Connect” website» page 13.

Remote access to the vehicle



Fig. 13 ŠKODA Connect application

With the **remote access to the vehicle** service, you can access some vehicle functions via the “ŠKODA Connect Portal” website or the “ŠKODA Connect” application installed on your mobile device.

After entering the following address into the web browser, the website is opened with information on the ŠKODA mobile applications.

<http://go.skoda.eu/service-app>

Installing the “ŠKODA Connect” mobile application

▶ Scan the QR code » Fig. 13 .

Remote access to the vehicle includes, for example, the following services.

- ▶ Driving data.
- ▶ Vehicle condition.
- ▶ Last parking position.
- ▶ Vehicle unlocking and vehicle locking.
- ▶ Online operation of the auxiliary heater.

i Note

The availability of the services listed always refers to the period of validity of the contract. During this interim period of validity, content changes of these services are possible. Current information can be found on the “ŠKODA Connect” website» page 13.

“Infotainment Online” services

Main menu and overview of services

Applies to Infotainment Columbus, Amundsen.

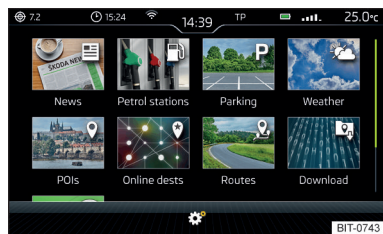













Fig. 14
Main menu

These services extend the functionality of the Internet-connected Infotainment.

To **display** the main menu » Fig. 14, tap the **MENU** sensor field and then tap the function surface .

-  News from the RSS channels set in the user profile on the “ŠKODA Connect Portal” website
-  Online search for filling stations with information on fuel prices » [page 185](#)
-  Online search for car parks with information on free parking spaces » [page 185](#)
-  Weather forecast near the vehicle position, the destination of the route or in the vicinity of the selected location
-  Online destination search » [page 183](#)
-  Import of the destinations created in the user profile on the “ŠKODA Connect Portal” website » [page 189](#)
-  Import of the routes created in the user profile on the “ŠKODA Connect Portal” website » [page 197](#)
-  Online updating of the navigation data (valid for the infotainment Columbus) and import of POI Categories » [page 181](#)
-  Conditions for the use of online services
-  Settings of Online Services » [page 138](#)

For more information on the available services, see the “ŠKODA Connect” website» [page 13](#).

Note

The availability of the services listed always refers to the period of validity of the contract. During this interim period of validity, content changes of these services are possible. Current information can be found on the “ŠKODA Connect” website» [page 13](#).

Safety

Passive Safety

General information

Introduction

This section of the manual includes important information on the subject of passive safety. We have combined everything here which you should be familiar with, for example, regarding seat belts, airbags, safety of children and anything similar.

Other important safety information can also be found in the following chapters of this Owner's Manual. The Owner's Manual should therefore always be in the vehicle.

Before setting off

For your own safety and the safety of the people travelling with you, please pay attention to the following points before setting off.

- ▶ Check the function of the lighting and turn signal systems.
- ▶ Check the function of the wipers and check the wiper blades for wear. Check the windscreen washer fluid level.
- ▶ Ensure that all of the windows offer good visibility to the outside.
- ▶ Adjust the rear-view mirror so that vision to the rear is guaranteed. Ensure that the mirrors are not covered.
- ▶ Check the tyre inflation pressure.
- ▶ Check the engine oil, brake fluid and coolant level.
- ▶ Secure all items of luggage.
- ▶ Do not exceed the permissible axle loads and permissible gross weight of the vehicle.
- ▶ Close all doors as well as the bonnet and boot lid.
- ▶ Ensure that no parts and components are visibly loose in the vehicle.
- ▶ Ensure that no objects can obstruct the pedals.
- ▶ Protect children by using a suitable child seat » [page 29, Transporting children safely](#).
- ▶ Adopt the correct seated position. Instruct your passengers to assume the correct seated position » [page 19, Correct and safe seating position](#).

Driving safety

In the interests of traffic safety, the following information must be observed.

- ▶ Do not become distracted from concentrating on the traffic situation, (e.g. by your passengers or mobile telephone calls).
- ▶ Never drive when your driving ability is impaired, (e.g. due to medication, alcohol or drugs).
- ▶ Keep to the traffic regulations and the permissible speed limit.
- ▶ Always adjust the driving speed to the road, traffic and weather conditions.
- ▶ Take regular breaks on long journeys (at least every two hours).

Correct and safe seating position

Introduction

Always assume the correct seated position before setting off and do not change this position while driving. Also advise your passengers to adopt the correct seated position and not to change this position while the car is moving.

The following list contains instructions for the **Passenger** which, if not observed, may cause serious injuries or death.

- ▶ Do not lean against the dash panel.
- ▶ Do not put your feet on the dash panel.

The following list contains instructions for all **Passengers** which, if not observed, may cause serious injuries or death.

- ▶ Do not sit only on the front part of the seat.
- ▶ Do not sit facing to the side.
- ▶ Do not lean out of the window.
- ▶ Do not put your limbs out of the window.
- ▶ Do not put your feet on the seat cushion.

! WARNING

- The adjustable seats and all head restraints must be adjusted to match the body size at all times and the seat belt must always be fastened properly to provide the most effective levels of protection to the passengers.
- Each occupant must correctly fasten the seat belt belonging to the seat. Children must be fastened » [page 29, Transporting children safely with a suitable restraint system.](#)
- The seat backrests must not be tilted too far back when driving, as this will impair the function of the seat belts and of the airbag system – risk of injury!

! WARNING

By sitting incorrectly, the occupant is risking life-threatening injuries.

Driver's correct seating position

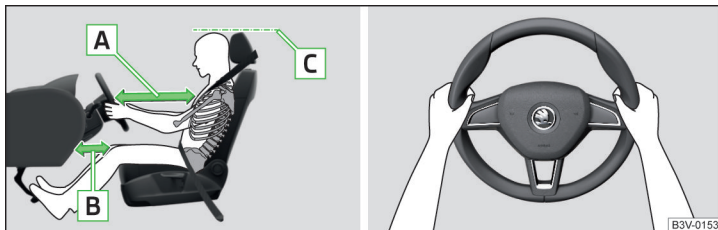

Fig. 15 Correct seated position for the driver/correct steering wheel position

📖 Read and observe ! on page 20 first.

For your own safety and to reduce the risk of injury in the event of an accident, the following instructions must be observed.

- ✓ Adjust the driver's seat in the forward/back direction so that the pedals can be fully depressed with slightly bent legs.
- ✓ For vehicles equipped with driver knee airbags, adjust the driver's seat in a forward/back direction so that there is a gap of at least 6 cm between the legs and the dashboard in the vicinity of the knee airbag » [Fig. 15 - \[B\]](#).

- ✓ Adjust the seat backrest so that the highest point of the steering wheel can be reached with your arms at a slight angle.
- ✓ Adjust the steering wheel so that the distance between the steering wheel and your chest is at least 25 cm » [Fig. 15 - \[A\]](#).
- ✓ Adjust the headrest so that the top edge of the headrest is at the same level as the upper part of your head (not for seats with integrated headrests) » [Fig. 15 - \[C\]](#).
- ✓ Correctly fasten the seat belt » [page 22, Using seat belts.](#)

! WARNING

- Maintain a distance of at least 25 cm from the steering wheel, and a distance of at least 6 cm between the legs and the dash panel at the height of the knee airbag. Not maintaining this minimum distance will mean that the airbag system will not be able to properly protect you - hazard!
- When driving, hold the steering wheel with both hands firmly on the outer edge in the "9 o'clock" and "3 o'clock" position » [Fig. 15.](#) Never hold the steering wheel in the "12 o'clock" position or in any other way (e.g. in the middle, inner edge of the steering wheel or similar). Otherwise, in the event of airbag deployment, you could suffer serious injury to the arms, hands and head.
- Ensure that no objects are located in the driver's footwell, as they could lodge in the pedal system whilst driving. You would then no longer be able to operate the clutch, brake or acceleration pedals.

Adjusting the steering wheel position



Fig. 16 Adjusting the steering wheel position

Read and observe **!** on page 20 first.

The height and forward/back position of the steering wheel can be adjusted.

- › Swing the safety lever under the steering wheel in the direction of arrow **1** » Fig. 16.
- › Adjust the steering wheel to the desired position. The steering wheel can be adjusted in direction of arrow **2**.
- › Pull the holder in arrow direction **3** until the stop.

! WARNING

- Never adjust the steering wheel when the vehicle is moving only when the vehicle is stationary!
- The safety lever must always be locked after adjusting so that the steering wheel cannot accidentally change position – risk of accident!

Correct seating position of the passenger

Read and observe **!** on page 20 first.

For passenger safety and to reduce the risk of injury in an accident, the following instructions must be observed.

- ✓ Position the front passenger seat back as far as possible. The front passenger must maintain a distance of at least 25 cm to the dash panel so that the airbag offers the greatest possible safety if it is deployed.
- ✓ Adjust the headrests so that the top edge of the headrest is at the same level as the upper part of your head » Fig. 15 on page 20 - **C** (not for seats with integrated headrests).
- ✓ Correctly fasten the seat belt » page 22, *Using seat belts*.

! WARNING

- Ensure a distance of at least 25 cm to the dashboard, otherwise the airbag system will not be able to protect you properly - risk of death!
- Always keep your feet in the footwell when the car is being driven – never place your feet on the instrument panel, out of the window or on the surface of the seats! You will be exposed to increased risk of injury if it becomes necessary to apply the brake or in the event of an accident. If an airbag is deployed, you could suffer fatal injuries by adopting an incorrect seated position!

Correct seating position for the passengers in the rear seats

Read and observe **!** on page 20 first.

For passenger safety on the rear seats and to reduce the risk of injury in the event of an accident, the following information must be observed.

- ✓ Adjust the headrests so that the top edge of the headrest is at the same level as the upper part of the head » Fig. 15 on page 20 - **C**.
- ✓ Correctly fasten the seat belt » page 22, *Using seat belts*.

Seat belts

Using seat belts

Introduction

Seat belts that are fastened correctly offer good protection in the event of an accident. They reduce the risk of an injury and increase the chance of survival in the event of a major accident.

The seat belts reduce the kinetic energy considerably. They also prevent uncontrolled movements which, in turn, may well result in severe injuries.

When transporting children, observe the following information » [page 29](#), *Transporting children safely*.

! WARNING

- Put the seat belt on before starting any journey! This also applies to other passengers - there is a danger of injury!
- Maximum seat belt protection is only achieved if you are correctly seated » [page 19](#), *Correct and safe seating position*.
- The seat backrests of the front seats must not be tilted too far to the rear otherwise the seatbelts can lose their effectiveness.

! WARNING

Information on dealing with the safety belts

- The belt webbing must not be jammed in-between at any point or twisted, or chafe against any sharp edges.
- Make sure you do not catch the seat belt in the door when closing it.

! WARNING

Information on the proper use of safety belts

- Adjust the height of the belt in such a way that the shoulder part of the belt is roughly positioned across the middle of your shoulder - on no account across your neck.
- No two persons (also not children) should ever use a single seat belt together.
- The lock tongue should only be inserted into the lock which is the correct one for your seat. Wrong use of the safety belt will reduce its capacity to protect and the risk of injury increases.

! WARNING (Continued)

- Many layers of clothing and loose clothing (e. g. a winter coat over a jacket) do not allow you to be correctly seated and impairs proper operation of the seat belts.
- Do not attach clamps or similar objects to the belt - the function of the belt retractor could be restricted.
- The seat belts for the rear seats can only fulfil their function reliably when the seat backrests are correctly locked into position » [page 87](#).

! WARNING

Information on the care and maintenance of safety belts

- The belt webbing must always be kept clean. Soiled belt webbing may impair the proper operation of the inertia reel » [page 264](#).
- The seat belts must not be removed or changed in any way. Do not attempt to repair the seat belts yourself.
- Check the condition of all the seat belts on a regular basis. If parts of the belt system become damaged (e.g. the belt webbing, the belt connections, the inertia reel, the locking part etc.), the respective seat belt must be replaced by a specialist garage immediately.
- Seat belts which have been subjected to stress in an accident must be replaced by a specialist garage. Also check the seat belt anchors.

Correct routing of seat belt

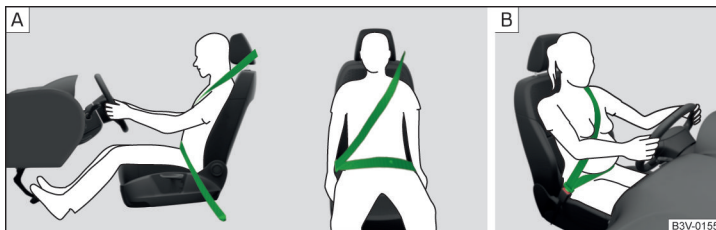

Fig. 17 Routing of belt webbing over the shoulders and the lap belt/Routing of belt webbing for an expectant mother

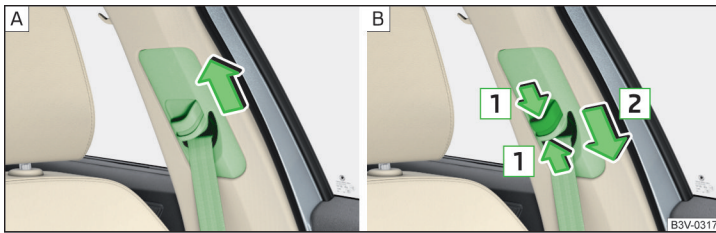

Fig. 18 Seat belt height adjusters for front seats

Read and observe **I** on page 22 first.

It is important that the belt is properly routed to ensure seat belts offer the maximum protection.

The **shoulder part of the belt** must run approximately over the middle of your shoulder (never across your neck) and fit well against your upper body » Fig. 17 - [A].

The **lap part of the belt** must run in front of the pelvis (must never run across your stomach) and must always fit snugly » Fig. 17 - [A].

In the case of **pregnant women**, the lap part of the belt must be positioned as low as possible on the pelvis to avoid exerting any pressure on the lower abdomen » Fig. 17 - [B].

Seat belt height adjusters for front seats

- Push the seat belt guide loop **upwards** in the direction of arrow » Fig. 18 - [A].
- **or**: push together the mechanism in the direction of arrow **1** and push the return pulley **downwards** in the direction of arrow **2** » Fig. 18 - [B].
- Then pull firmly on the belt to ensure that the seat belt height adjuster has correctly locked in place and that the belt is blocked reliably » page 24, *Inertia reels*.

! WARNING

- Always ensure that the webbing of the seat belts is properly routed. Seat belts which are not correctly adjusted can themselves cause injuries even in minor accidents.
- A seat belt which is hanging too loose can result in injuries as your body is moved forward by the kinetic energy produced in an accident and is then suddenly held firm by the belt.
- The belt webbing must not run across solid or fragile objects (e.g. spectacles, ball-point pens, keys, etc.). Such objects can cause injury.

Fastening and unfastening seat belts

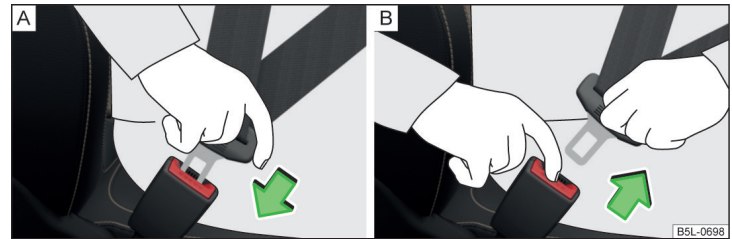

Fig. 19 Fastening/unfastening the seat belt

Read and observe **I** on page 22 first.

Before fastening

- Adjust the headrest properly (does not apply to seats with integrated headrests).
- Adjusting the seat (applies to the front seats).
- Adjust the belt height (applies to the front seats).

Fasten

- Slowly pull the belt over the chest and pelvis.
- Insert the lock tongue into the belt buckle for the seat » Fig. 19 - [A] until it audibly clicks into place.
- Pull on the belt to check that it has engaged correctly in the lock.

Release

- Hold the lock tongue and press the red button in the belt buckle » Fig. 19 - [B]. The lock tongue pops out.

› Feed the belt back manually so that the seat belt is not twisted and the belt webbing rolls up completely.

! WARNING

The slot of the belt tongue must not be blocked, otherwise the belt tongue will not lock in place properly.

Inertia reel and belt tensioners

Inertia reels

Each seat belt is equipped with an inertia reel.

When pulling slowly on the seat belt, the belt can move freely. When pulling sharply on the seat belt, the movement is locked by the inertia reel. The belts also lock when full braking, when the car accelerates, when driving downhill and when cornering.

! WARNING

If the seat belt does not lock when pulling sharply on it, have the inertia reel inspected immediately by a specialist garage.

Belt tensioners

The safety for the driver, front passenger and passengers on the outer rear seats **who are wearing their seat belts**, is enhanced by the belt tensioners fitted to the inertia reels on the front and rear external seat belts.

If there is a collision with a certain severity the seat belts are tightened by the belt tensioner so that unwanted body motion is prevented.

Belt tensioners are **not activated** in the event of a roll-over, **minor** collisions or in accidents in which no major forces are produced.

! WARNING

- Any work on the belt tensioner system, including the removal and installation of system components because of other repair work, must only be carried out by a specialist garage.
- If the belt tensioners have been deployed, it is then necessary to replace the entire system.

i Note

- The belt tensioners can also be deployed if the seat belts are not fastened.
- Smoke is generated when the belt tensioners are deployed. This is not an indication of a fire in the vehicle.

Reversible belt tensioners

As part of the proactive passenger protection system, reversible seat belts increase the safety of the **belted up** driver and front passenger.

In critical driving situations the seat belt is tensioned tightly over the body and then released again by the reversible belt tensioner.

Further information » [page 246](#), *Proactive occupant protection (Crew Protect Assist)*.

Airbag system

Description of the airbag system

Introduction

As a supplement to the seat belts, the airbag system provides additional passenger protection in the event of severe frontal and side collisions.

The best possible protective effect of the airbag can only be achieved if the seat belts are applied properly. The airbag is not a substitute for the seat belts.

The functional status of the airbag system is indicated by the warning light  in the instrument cluster [» page 42](#).

System description

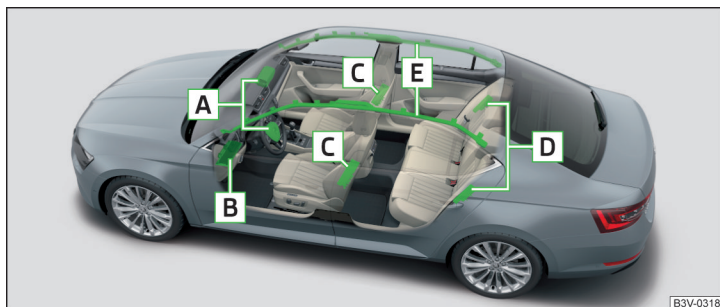

Fig. 20 Installation locations of airbags

Installation locations of airbags [» Fig. 20](#)

- A** Front airbags
- B** Driver's knee airbag
- C** Front side airbags
- D** Rear side airbags
- E** Head airbags

The forward movement of the body is cushioned when it makes contact with the fully inflated airbag and the risk of injury to the remaining body parts is thus reduced.

- ▶ **Front airbags** - head and upper body. The airbags can be identified by the lettering **AIRBAG** featured on the steering wheel and on the dash panel on the passenger side.
- ▶ **Driver's knee airbag** - Legs. The airbag features the lettering **AIRBAG** on the dashboard on the driver's side.
- ▶ **Side airbags** - for the entire upper body (chest, stomach, pelvis) on the side next to the door. The side air bags can be identified by a label with the lettering **AIRBAG** marked on the front seat backrests. The rear side airbags are provided with the lettering **AIRBAG** in between the entrance area and the rear seat backrest.
- ▶ **Head airbags** - head and neck. The airbags are provided with the lettering **AIRBAG** marked on the B-pillar cladding.

Depending on the vehicle equipment, the airbag system consists of the following parts.

- ▶ Individual airbags.
- ▶ Warning light  in the instrument cluster [» page 42](#).
- ▶ Key switch for the front passenger airbag [» page 28](#).
- ▶ Warning light for the front passenger airbag in the middle of the dash panel [» page 28](#).

Airbag deployment

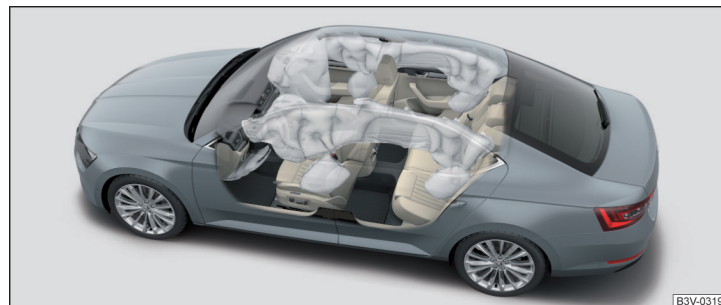

Fig. 21 Inflated airbags

The airbag system is only functional when the ignition is switched on.

When triggered, the airbag is filled with gas and unfolds. The inflation of the airbag is carried out in a fraction of a second.

Upon inflation of the airbag, smoke is released. This is not an indication of a fire in the vehicle.

Triggering conditions

It is not possible to generally determine which deployment conditions apply to the airbag system in every situation. Important here is the hardness of the object on which the vehicle impacts, the impact angle, the vehicle speed, etc.

Deceleration during impact plays an important role in the deployment of the airbags. If the vehicle deceleration which occurs and is measured remains below the prescribed reference values specified in the control unit, the airbags are not deployed although the vehicle may well suffer severe damage to the bodywork as a consequence of the accident.

The following airbags will be deployed in the event of a severe frontal collision.

- ▶ Driver's front airbag.
- ▶ Front passenger airbag.
- ▶ Driver's knee airbag.

The following airbags will be deployed in the event of a severe side collision.

- ▶ Front side airbag.
- ▶ Rear side airbag.
- ▶ Head airbag.

When an airbag is deployed, the following events occur.

- ▶ The hazard warning lights are switched on.
- ▶ All doors are unlocked.
- ▶ The fuel supply to the engine is interrupted.
- ▶ The interior light comes on (if the automatic operation of the interior light is switched on - switch .

When there is no air bag deployment?

With **minor** frontal and side collisions, rear collision, overturning of the vehicle or vehicle roll-over there is no airbag deployment.

Safety instructions

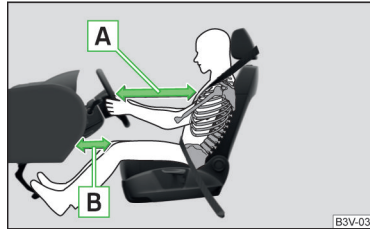

Fig. 22
Safe distance from the steering wheel and the dashboard

! WARNING

General information

- **The seat belts and the airbag system can only offer proper protection if the driver and passengers are seated properly » page 19.**
- The airbag develops considerable forces when triggered, which can lead to serious injuries or even death if the correct seating position or seated position is not observed. This applies in particular to children who are transported without using a suitable child safety seat » page 30.
- If there is a fault, have the airbag system checked immediately by a specialist garage. Otherwise, there is a risk of the airbag not being activated in the event of an accident.
- The airbag system must be replaced if it has been deployed.
- In the area of the front airbag and the knee airbag, the surface of the steering wheel and the dashboard should be cleaned using only a dry cloth or one that has been dampened with water.

! WARNING

Information about front airbags

- It is important for the driver and front passenger to maintain a minimum distance of 25 cm from the steering wheel or the control panel » Fig. 22 - . If you do not observe this distance, the airbag cannot protect you - risk to life! The front seats and the head restraints must always be correctly adjusted to match the body size of the occupant.
- The front passenger airbag must be deactivated if using a rear-facing child seat on the front passenger seat » page 27, *Airbag deactivation*. If this is not done, there is a risk of the child suffering severe or even fatal injuries if the front passenger airbag is deployed.

! WARNING (Continued)

- No other persons, animals or objects may be positioned in front of the occupants on the front seats in the deployment area of the front air bags.
- The steering wheel and the surface of the dashboard on the front passenger side must not have stickers attached, covered or modified in any other way. No parts (e.g. cup holders, mobile telephone mounts etc.) should be mounted in the vicinity of the airbag installation locations and in the airbag deployment area.
- Never place objects on the surface of the dashboard on the front passenger side.

! WARNING

Information about knee airbags

- Adjust the driver's seat in a forward/back direction so that there is a gap of at least 6 cm between the legs and the dashboard in the vicinity of the knee airbag » Fig. 22 - **B**. If it is not possible to meet this requirement due to your body size, visit a specialist garage.
- The surface of the airbag module in the lower part of the dash panel below the steering column not have stickers attached, be covered or modified in any other way. Nothing may be attached to the cover of the airbag module or located within the immediate vicinity.
- Do not attach any bulky and heavy objects (bunch of keys etc.) to the ignition key. These can be ejected by the knee airbag when it is deployed and can cause injuries.

! WARNING

Information about for side and head airbags

- No objects (e.g. sun visors turned towards the windows) should be located in the deployment area of the side and head airbags. No accessories (e.g. cup holders etc.) should be fitted to the doors - risk of injury!
- Hang only light clothing on clothes hooks in the vehicle. Do not leave any heavy or sharp objects in the pockets of the clothing. Do not use clothes hangers to hang the clothing.
- The airbag system operates using pressure sensors located in the front doors. For this reason, no adjustments may be carried out to the doors or door panels (e.g. installation of additional loudspeakers). Further information » page 260.

! WARNING (Continued)

- No excessive forces, such as knocks, kicks etc., should be exerted on the seat backrests - there is a risk of damage to the side air bags. The side airbags would not be deployed in such a case!
- Any seat or protective covers which you fit to the driver or front passenger seats must only be of the type expressly authorized by ŠKODA. In view of the fact that the airbag inflates out of the backrest of the seat, use of non-approved seat or protective covers would considerably impair the protective function of the side airbag.
- Have any damage to the original seat covers or stitching at the installation point of the side airbags repaired immediately by a specialist garage.

! WARNING

Information on the use of the airbag system

- Any work on the airbag system including the installation and removal of system components due to other repair work (e.g. removal of the seat) must only be carried out by a specialist garage. Further information » page 260.
- No modifications should be made to parts of the airbag system, to the front bumper or to the body.
- Do not manipulate individual parts of the airbag system, as this might result in the airbag being deployed.

Airbag deactivation

Deactivating airbags

The front passenger airbag can be switched off with the key-operated switch » Fig. 23 on page 28 - **A**.

We recommend that you ask a ŠKODA service partner to deactivate any other airbags.

The airbag deactivation is displayed by the warning light  » page 42. ▶

Deactivating an airbag should be considered in cases such as the ones below.

- ▶ A child seat is mounted on the front passenger seat, in which the child is transported with its back to the direction of travel » [page 29](#).
- ▶ Despite correct adjustment of the driver's seat, the distance of at least 25 cm between the middle of the steering wheel and chest cannot be maintained.
- ▶ Additional controls for drivers with a physical disability are installed in the vehicle.
- ▶ Special seats (e.g. orthopaedic seats without side airbags) are installed in the vehicle.

! WARNING

If an airbag is deactivated upon the sale of the vehicle, the buyer must be informed of this!

Deactivating the front passenger airbag

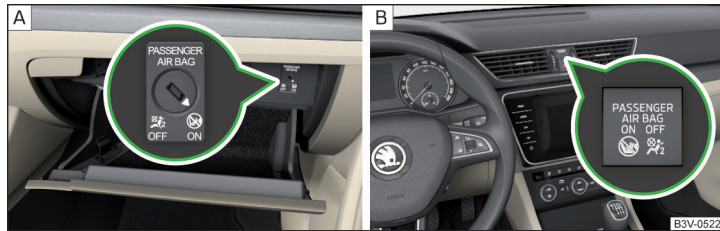

Fig. 23 Key-operated switch for the front passenger airbag / warning light for front passenger airbag

Positions of the key switch » [Fig. 23](#) - **A**

OFF The front passenger airbag is deactivated - after the ignition is switched on, the indicator light **OFF** » [Fig. 23](#) illuminates **B**

ON The front passenger airbag is activated - after the ignition is switched on, the indicator light illuminates for 65 seconds **ON**

Switch off

- ▶ Switch off the ignition.
- ▶ Open the storage box on the front passenger's side.

- ▶ Fold out the key bit **completely** » **!**. With a KESSY key, remove the emergency key.
- ▶ Carefully insert the key into the slot in the key switch as far as the stop.
- ▶ Use the key to turn the slot of the key switch carefully into the position **OFF**.
- ▶ Pull the key out of the slot in the key switch » **!**.
- ▶ Close the storage compartment on the front passenger side.
- ▶ Check that the warning light **OFF** » illuminates after the ignition is switched on.

Switching on

- ▶ Switch off the ignition.
- ▶ Open the storage compartment on the front passenger side.
- ▶ Fold out the key bit **completely** » **!**. With a KESSY key, remove the emergency key.
- ▶ Carefully insert the key into the slot in the key switch as far as the stop.
- ▶ Use the key to turn the slot of the key switch carefully into the position **ON**.
- ▶ Pull the key out of the slot in the key switch » **!**.
- ▶ Close the storage compartment on the front passenger side.
- ▶ Check that the warning light **ON** » illuminates after the ignition is switched on.

! WARNING

- The key cannot be inserted into the key switch while driving. Shocks can cause the key to turn in the slot and trigger the airbag! The airbag can be triggered unexpectedly in an accident - it may result in injury or death!
- The driver is responsible for whether the airbag is switched on or switched off.
- Only switch off the airbag when the ignition is switched off! Otherwise a fault can occur in the system for deactivating the airbag.
- If the warning lights **ON** » **OFF** » flash, the front passenger airbag will not be deployed in the event of an accident! Have the airbag system checked by a specialist garage immediately.

! CAUTION

An insufficiently folded out key bit can damage the key switch!

Transporting children safely

Child seat

Introduction

To reduce the risk of injury in the event of an accident, children must be transported in child seats!

The information in this Owner's Manual as well as the instructions of the child seat manufacturer must be observed when installing and using the child seat.

For safety reasons, we recommend that you always transport child seats on the rear seats. Children should be transported on the front passenger seat only in exceptional circumstances.

Child seats complying with the ECE-R 44 Economic Commission for Europe standard must be used.

Child seats that comply with the ECE-R 44 standard are identified with a test mark that cannot be removed: large E within a circle with the test number below.

! WARNING

- One should never carry children, and also not babies! - on one's lap.
- When leaving the vehicle, do not leave children unattended in the vehicle. Children might not be capable of leaving the vehicle or helping themselves independently in the event of an emergency. Very high or low temperatures can be fatal!
- The child must be secured in the vehicle during the entire journey! Otherwise, the child would be thrown through the vehicle in the event of an accident, causing fatal injuries to both the child and other occupants.
- Children are exposed to an increased risk of injury in the event of an accident if they lean forward or adopt an incorrect seated position when the vehicle is moving. This particularly applies to children who are transported on the front passenger seat as they can suffer severe, or even fatal injuries if the airbag system is deployed!
- Pay particular attention to the information provided by the manufacturer of the child safety seat regarding the correct routing of the belt. Seat belts which are not correctly adjusted can themselves cause injuries even in minor accidents.

! WARNING (Continued)

- Safety belts must be checked to ensure that they are running properly. One should also ensure that the belt is not damaged by sharp-edged fittings.
- When installing the child seat on the back seat, the corresponding front seat must be adjusted so that there is no contact between the front seat and the child seat or the child being transported in a child seat.
- Before installing a forward-facing child seat with backrest, remove the headrest » page 89. After removing the child seat, refit the head restraints.

i Note

We recommend that you use child seats from ŠKODA Original Accessories. These child seats were developed and also tested for use in ŠKODA vehicles. They meet the ECE-R 44 standard.

Use of a child seat on the front passenger seat (variant 1)

Does not apply to Taiwan



Fig. 24 Warning labels

Read and observe ! on page 29 first.

Never use a rear-facing child restraint system on a seat which is protected by an active airbag positioned in front of it. This could cause serious injury to the child, even death.

This is indicated also on stickers that are located at the following positions.

- ▶ On the front passenger's sun visor » Fig. 24 - [A].
- ▶ On the B-pillar on the front passenger side » Fig. 24 - [B].

The following instructions must be followed when using a child seat on the front passenger seat.

- ▶ The front passenger airbag must be deactivated if using a rear-facing child seat » [1].
- ▶ If possible, adjust the front passenger seat backrest so that it is as vertical, so as to ensure secure contact between the passenger seat backrest and the back of the child seat.
- ▶ If possible, move the front passenger seat backwards so that there is no contact between the front passenger seat and the child seat behind it.
- ▶ Set the height-adjustable front passenger seat as high up as possible.
- ▶ Set the front passenger seat belt as high up as possible.
- ▶ With child safety seats in groups 2 and 3, make sure that the loop-around fittings attached to the child seat headrest is positioned **in front of or at the same height** as the loop-around fittings on the B pillar on the passenger side. Adjust the height of the front passenger seat belt so that the belt does not "jam" in the return pulley. In the event of an accident, there is the risk of injury to the neck of the child carried due to the seat belt!

! WARNING

- **Never** use a rear-facing child seat on the front passenger seat if the passenger airbag is activated. This child safety seat is positioned in the deployment area of the front passenger airbag. The airbag may cause the child severe, or even fatal injuries, in the event of it being deployed.
- As soon as the child seat, in which the child is transported with their back in the direction of travel, is no longer used in the front passenger seat, the front passenger airbag should be switched on again.

Use of a child seat on the front passenger seat (variant 2)

Applies to Taiwan



Fig. 25
Warning stickers

Read and observe [1] on page 29 first.

No babies, infants or children to be carried on the passenger seat.

A sticker to this effect can also be found on the front passenger's sun visor » Fig. 25.

Child safety and the side airbag

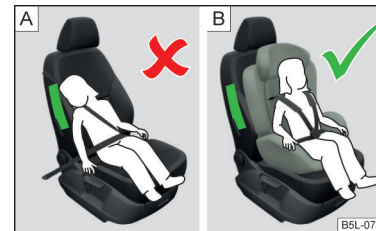

Fig. 26
Incorrect seated position of a child who is not properly secured – risk from the side airbag/Child properly protected by safety seat

Read and observe [1] on page 29 first.

The child must not be positioned in the deployment area of the side airbag
» Fig. 26 - [A].

There must be sufficient room between the child and the area into which the side airbag will deploy to allow the airbag to provide as much protection as possible » Fig. 26 - [B].

Classification of child seats

📖 Read and observe **I** on page 29 first.

Classification of child seats according to the ECE-R 44 standard.

Group	Weight of the child
0	up to 10 kg
0+	up to 13 kg

Group	Weight of the child
1	9 - 18 kg
2	15 - 25 kg
3	22-36 kg

Use of child safety seats which are secured using a seat belt

Never use a rear-facing child seat on the front passenger seat if the passenger airbag is activated. This child safety seat is positioned in the deployment area of the front passenger airbag. The airbag may cause the child severe, or even fatal injuries, in the event of it being deployed.

📖 Read and observe **I** on page 29 first.

Overview of the usability of child seats secured with a seat belt on seats in accordance with the ECE-R 16 standard.

Group	Passenger seat with activated front airbag	Passenger seat with deactivated front airbag	Rear seats Outside	Rear seat Centre
0 up to 10 kg	X	U ^{a)}	U	U
0+ up to 13 kg	X	U ^{a)}	U	U
1 9 - 18 kg	UF	U	U	U
2 15 - 25 kg	UF	U	U	U
3 22 - 18 kg	UF	U	U	U

^{a)} Set the height-adjustable front passenger seat as high up as possible.

- U** The seat is suitable for the use of approved child seats in this weight group category "Universal".
- UF** The seat is suitable for the use of approved forward-facing child seats in the "Universal" weight group category.
- X** The seat is not suitable for children in this weight group.

Fastening systems

attachment points of the ISOFIX system

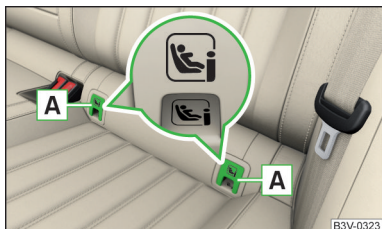

Fig. 27
Labels of the system ISOFIX

ISOFIX is a system for securing child seats quickly and safely.

Two locking eyes are located between the seat backrest and the seat cushion of the outer rear seats and front passenger seat for fixing the ISOFIX system child seat in place.

Use of child safety seats with the ISOFIX System

Never use a rear-facing child seat on the front passenger seat if the passenger airbag is activated. This child safety seat is positioned in the deployment area of the front passenger airbag. The airbag may cause the child severe, or even fatal injuries, in the event of it being deployed.

Overview of the usability of child seats fastened with the ISOFIX system on each of the seats in accordance with the ECE-R 16 standard.

Group	Size class of the child seat ^{a)}	Front passenger seat ^{b)}	Rear seats outside	Rear seat middle
0 up to 10 kg	E	X	IL	X
0+ up to 13 kg	E	X	IL	X
	D			
	C			
1 9 - 18 kg	D	X	IL IUF	X
	C			
	B			
	B1			
	A			

First, remove the caps **A** in order to access the locking eyes» Fig. 27. After removing the child seat, replace the caps.

! WARNING

- Always refer to the instructions of the manufacturer of the child seat when installing and removing a child seat with the ISOFIX system.
- Never attach other child seats, belts or objects to the attachment points intended for the installation of a child seat with the ISOFIX system – risk of death!

i Note

- A child seat fitted with the ISOFIX system can only be mounted in a vehicle fitted with a ISOFIX system if the child seat has been approved for this type of vehicle. Further information is available from a ŠKODA Partner.
- Child seats with the ISOFIX system can be purchased from ŠKODA Original Accessories.

Group	Size class of the child seat ^{a)}	Front passenger seat ^{b)}	Rear seats outside	Rear seat middle
2 15 - 25 kg	-	X	IL	X
3 22 - 18 kg	-	X	IL	X

a) The size category is shown on the label attached to the child seat.

b) If the front passenger seat is fitted with ISOFIX system attachment points, it is suitable for the installation of an ISOFIX child seat with "Semi-Universal" approval.

IL The seat is suitable for installation of a ISOFIX child seat with the "Semi-Universal" approval. The "Semi-Universal" category means that the child seat with the ISOFIX system is approved for your vehicle. Observe the list of vehicles that comes with the child seat.

IUF The seat is suitable for the use of approved forward-facing child seats in the "Universal" weight group category.

X The seat is not fitted with ISOFIX system attachment points.

Using child seats with the i-Size system

Front passenger seat	Rear seats outside	Rear seat middle
X	i-U	X

i-U The seat is suitable for forward and backward facing i-Size child seats of the category "Universal".

X The seat is not suitable for the i-Size child seat of the category "Universal".

Attachment points of the TOP TETHER system

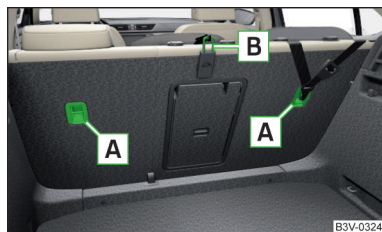

Fig. 28
Attachment points of the TOP TETHER-system

TOP TETHER is a fastening system, which restricts the movement of the upper part of the child seat.

The locking eyes **A** for attaching the belt of a child seat with the TOP TETHER system are located on the rear side of the rear seat backrests » Fig. 28.

Some country-specific models can also be fitted with an attachment point **B** » Fig. 28.

! WARNING

- Always refer to the instructions from the manufacturer of the child seat when installing and removing a child seat with the TOP TETHER system.
- Only use child seats with the TOP TETHER system on the seats equipped with attachment points with the logo TOP TETHER.
- Only ever attach one belt from the child seat to a locking eye.

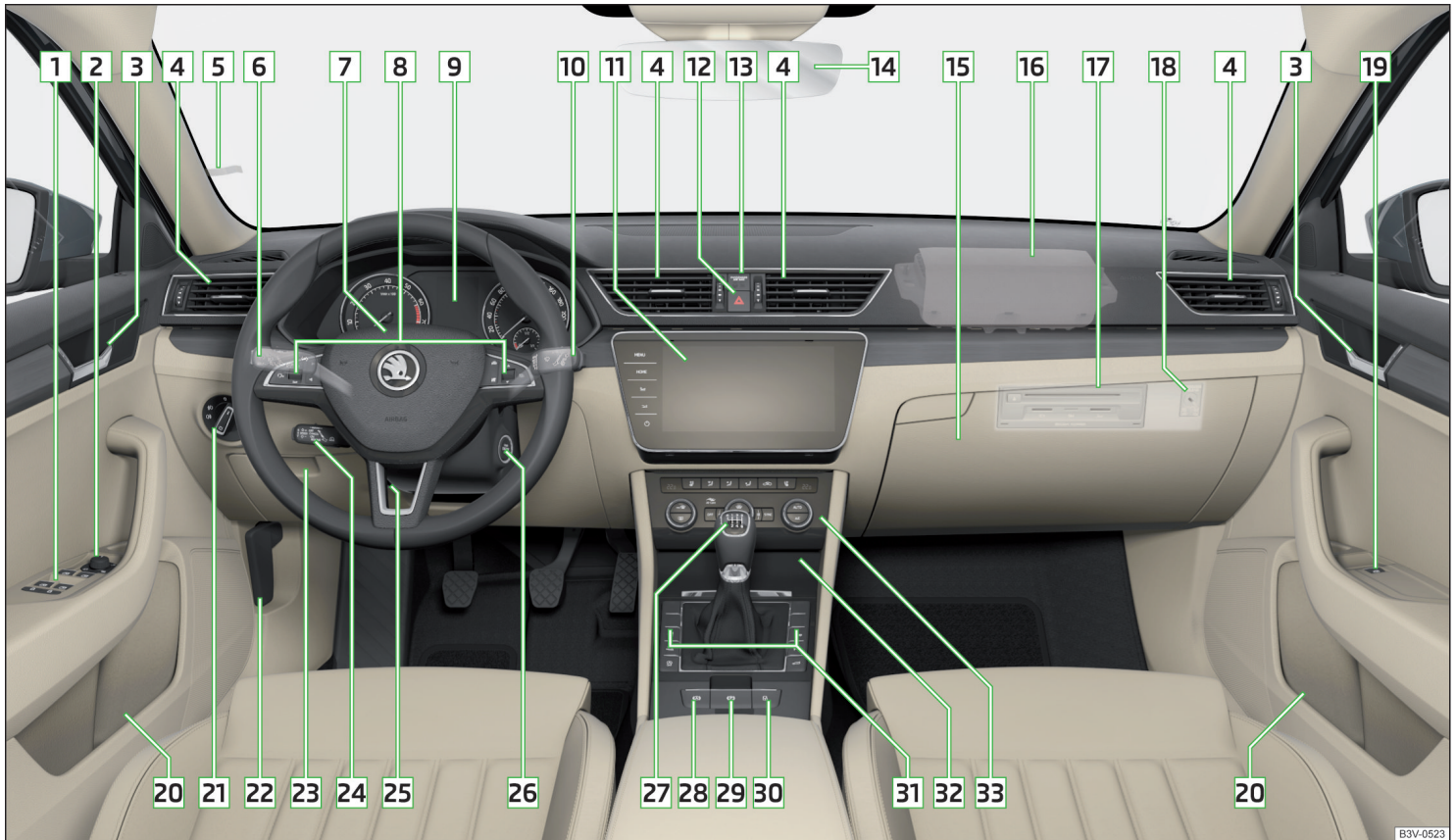







Fig. 29 Cockpit example for LHD

B3V-0523

Using the system

Cockpit

Overview

1	Electric power windows	66
2	Electric exterior mirror adjustment	82
3	Door opening lever	61
4	Air outlet vents	121
5	Ticket holder	92
6	Operating lever (depending on equipment):	
	▶ Indicator light and high-beam headlight	71
	▶ Speed regulating system	234
	▶ Speed limiter	235
	▶ Headlamp assistant	74
7	Steering wheel with horn/with driver's front airbag	25
8	Buttons for operating the information system	48
9	Instrument cluster	36
10	Operating lever:	
	▶ Windscreen wipers and washers	79
	▶ Information system	48
11	Infotainment	125
12	Button for hazard warning light system	73
13	Warning light for the front seat passenger airbag	28
14	Interior rear-view mirror	81
15	Storage compartment on the front passenger side	97
16	Front passenger airbag	25
17	External Infotainment module (in the passenger storage compartment)	127
18	Key switch for switching off the front passenger airbag (in front passenger storage compartment)	28
19	Power window in the front passenger door	66
20	Storage compartment	93
21	Light switch	70
22	Bonnet release lever	270
23	Storage compartment	92
24	Operating lever for adaptive cruise control	239
25	Steering wheel locking lever	21
26	Depending on equipment fitted:	
	▶ Ignition lock	205
	▶ Starter button	205
27	Depending on equipment fitted:	
	▶ Gearshift lever (manual gearbox)	211
	▶ Selector lever (automatic gearbox)	212
28	Auto-hold button	209
29	Button for the electric parking brake	208
30	Central locking button	59
31	Bars with buttons (depending on the equipment fitted):	
	▶  START STOP	206
	▶  Stabilisation control ESC / Traction control TCS	217, 218
	▶  Selection of travel mode	244
	▶  Park Assist	229
	▶  Parking aid	219
32	Storage compartment	93
	Depending on equipment fitted:	
	▶ Phonebox	93
	▶ 12-Volt power socket	100
	▶ Cigarette lighter	103
	▶ Ashtrays	102
	▶ USB input	94
33	Controls for heating/air conditioning	117

i Note

The layout of the controls on right-hand drive vehicles differs partially from that shown in » Fig. 29.

Instruments and warning lights

Instrument cluster

Introduction

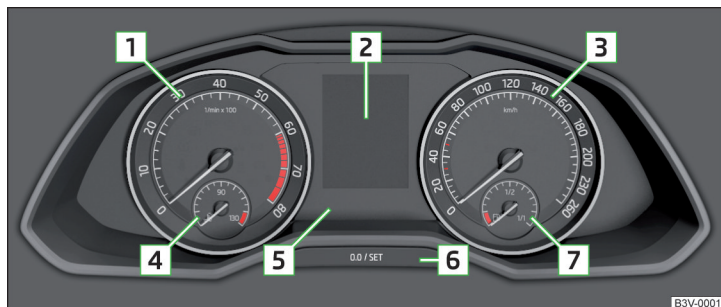

Fig. 30 Instrument cluster

- 1 Engine revolutions counter » page 36
 - ▶ with warning lights » page 39
- 2 Display » page 48
- 3 Speedometer
 - ▶ with warning lights » page 39
- 4 Coolant temperature gauge » page 36
- 5 Bar with warning lights » page 39
- 6 Operation button
 - ▶ Set the time » page 49
 - ▶ Reset counter for distance travelled (trip) » page 48
 - ▶ Displaying the distance and days until the next service interval » page 55
- 7 Fuel gauge » page 37

The brightness of the instrument illumination is set automatically depending on the ambient lighting throughout. If the visibility is poor and the lights are not on, the brightness of the instrument lighting reduces to alert the driver to switch on the lights in due time.

The brightness of the instrument lighting can be adjusted in Infotainment in the menu **CAR** / → → **Light**.

Engine revolutions counter

The tachometer **1** » Fig. 30 on page 36 shows the actual engine speed per minute.

The beginning of the tachometer red scale range indicates the maximum permitted speed for an engine that has been driven-in and has reached operating temperature.

You should shift into the next highest gear before the red scale of the revolution counter is reached, or select mode **D/S** on the automatic gearbox.

The gear recommendation is important to note in order to maintain the optimum engine speed » page 49.

! CAUTION

The pointer of the engine revolutions counter must reach the red area for only a short time - there is a risk of engine damage!

Coolant temperature gauge

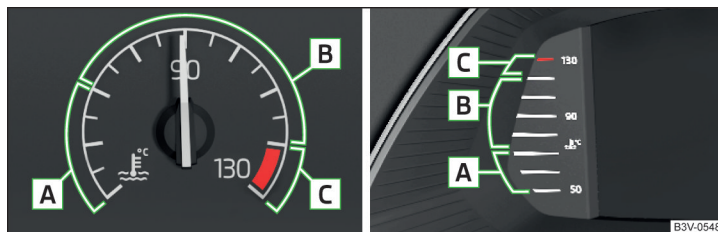

Fig. 31 Coolant temperature gauge

The display only works if the ignition is switched on.

- A Cold area**, The engine has not yet reached its operating temperature. Avoid high speeds and high engine loads.
- B The operating range**
- C High temperature range**, the warning light illuminates in the instrument cluster » page 45.

Fuel gauge



Fig. 32 Fuel gauge

The display only works if the ignition is switched on.

The fuel tank has a capacity of about 66 litres.

If the fuel level reaches the reserve level **A**, the » Fig. 32 indicator light in the instrument cluster **B** illuminates » page 43.

! WARNING

For the vehicle systems to function correctly, and thus for safe driving, there must be sufficient fuel in the tank. Never drain the fuel tank completely – risk of accident!

! CAUTION

Never drive until the fuel tank is completely empty! The irregular supply of fuel can cause misfiring, which can result in damage to parts of the engine and the exhaust system.

i Note

The arrow ► next to the symbol **B** within the fuel gauge displays the installation location of the fuel filler on the right side of the vehicle.

Display in the rear centre console



Fig. 33 Display in rear centre console

The following information is shown in the display depending on the equipment installed on the vehicle.

- Time
- Exterior temperature information
- Information on the Climatronic set temperature for occupants in the rear seats

Digital instrument cluster

Introduction



Fig. 34 Digital instrument panel

- 1 Bar with warning lights » page 39
- 2 Coolant temperature gauge » page 36
- 3 Display » page 38
- 4 Fuel gauge » page 37

The brightness of the instrument illumination is set automatically depending on the ambient lighting throughout.

The brightness of the instrument lighting can be adjusted in Infotainment in the menu **CAR** / → → → **Light**.

Display in the digital instrument cluster



Fig. 35 Display versions / example of the classic display

- A** Display versions (from the left)
- ▶ **Classic display**
 - ▶ **Advanced display**
 - ▶ **Modern display**

- ▶ **Basic display**
- ▶ **Sporty display**

- B** Central display area
C Additional information

Operating the instrument cluster



Fig. 36 Buttons/dial on the multifunction steering wheel

- A** **Rotate** - Movement in the selected menu / setting values / Manually change map scale (applies to Infotainment Columbus, Amundsen)
Press - confirm selected menu item
Turn and press - switch on automatic change of the map scale (applies to Infotainment Columbus, Amundsen)
- VIEW Press** - Change the display version » Fig. 35 on page 38
Hold - Display the prefix options menu with additional information
- Press** - display main menu / return to a previous level in the menu » page 53

pre-selection options for additional information



Fig. 37 Set the pre-selection option in Infotainment

Select the pre-selection option



- ▶ Hold the button on the **VIEW** multi-function steering wheel.

► Select and confirm one of the following pre-selection options.

- **Auto** - additional information is displayed depending on the driving mode selected
- **Classic** - Information on the engaged gear and the current speed
- **View 1** - adjustable pre-selection option
- **View 2** - adjustable pre-selection option
- **View 3** - adjustable pre-selection option















Set the preselection option































The area code options **View 1**, **View 2** and **View 3** can be found in infotainment in the menu  in the  → **Dig. Instrument cluster** menu item.

- The desired additional information can be selected by moving your finger vertically across the display in the  » **Fig. 37** areas.
- Hold the desired function surface for the preselection option in area  to save the selection.

Warning lights

Introduction

	Parking brake	» page 40
	Brake system	» page 40
	Front seat belt warning light	» page 40
	Adaptive Cruise Control (ACC)	» page 40
	Power steering Steering lock (KESSY system)	» page 41
	Stabilisation control (ESC)	» page 41
	Traction control (TCS)	
	Traction control (ASR) deactivated	» page 42
	Antilock brake system (ABS)	» page 42
	Rear fog light	» page 42
	Exhaust control system	» page 42
	Glow plug system (diesel engine)	» page 42
	EPC fault light (petrol engine)	» page 42
	Safety systems	» page 42
	Tyre pressure	» page 43

	Brake pads	» page 43
	Fuel reserve	» page 43
	Lane Assist	» page 44
	Turning signal system	» page 44
	Trailer turn signal lights	» page 44
	Fog lights	» page 44
	Speed regulating system Speed limiter	» page 44
	Brake pedal (automatic gearbox)	» page 44
	Auto Hold function	» page 44
	High beam	» page 44
	Automatic gearbox	» page 44
	Rear seat belt warning light	» page 45
	Alternator	» page 45
	Coolant	» page 45
	Engine oil pressure	» page 45
	Engine oil level	» page 45
	AdBlue® level too low (diesel engine)	» page 46
	AdBlue® error (diesel engine)	» page 46
	Bulb failure	» page 46
	Display when the light is switched off	» page 46
	Particle filter	» page 46
	Windscreen washer fluid level	» page 47
	Headlamp assistant	» page 47
	START-STOP system	» page 47
	Display of a low temperature	» page 47
	Water in fuel filter (diesel engine)	» page 47
	Adaptive Cruise Control (ACC)	» page 47
	Distance warning (Front Assist)	» page 47
	Front Assist	» page 47
	Emergency call	» page 47
	Economy mode	» page 48



	Adaptive chassis (DCC)	» page 48
	Service	» page 48

The warning lights in the instrument cluster indicate certain functions or faults.



Some warning lights can be accompanied by acoustic signals and messages in the display of the instrument cluster.

After switching on the ignition, some warning lights **light up** briefly as a function test. If the tested systems are OK, the corresponding warning lights go **out** a few seconds after switching on the ignition or after starting the engine.

Warning lights in the display

Depending on the significance, the warning light  (danger) or  (warning) illuminates along with some other warning lights in the display.

Depending on vehicle equipment fitted, some indicator lights can be shown in the display. For example, the coolant warning light can be shown as follows.

- ▶  - monochrome ("black and white") display
- ▶  - coloured display

WARNING

- Ignoring illuminated warning lights and related messages or instructions in the display of the instrument cluster may lead to serious personal injury or damage to the vehicle.
- If you have to stop for technical reasons, then park the vehicle at a safe distance from the traffic, switch off the engine and switch on the hazard warning lights » page 73. Place the warning triangle at the prescribed distance.
- The engine compartment of your car is a hazardous area. While working in the engine compartment, be sure to observe the following warnings » page 269.

Parking brake

 **Read and observe  on page 40 first.**

 illuminates - the parking brake is switched on.

Parking brake error

 illuminates

Message: **Fault: electronic parking brake**

40 Using the system

- ▶ Seek help from a specialist garage.

Parking on a slope that is too steep

 illuminates

Message: **Parking brake: Gradient too steep. Log book!**

- ▶ Find a parking space on a flat surface or on a slope that is not so steep.





Brake system

 **Read and observe  on page 40 first.**

 lights up - the brake fluid level in the brake system is too low.

- ▶ Stop the vehicle, switch off the engine, and check the level of the brake fluid » page 273.

WARNING

- If warning light  illuminates simultaneously with warning light  » page 42,  Anti-lock braking system (ABS),  **stop driving!** Seek help from a specialist garage.
- A fault to the ABS system or the braking system can increase the vehicle's braking distance - risk of accident!

Front seat belt warning light

 **Read and observe  on page 40 first.**

 illuminates - the driver or front passenger has not fastened their seat belt.

At a speed of more than approximately 30 km/h, the warning light  flashes and an audible warning sounds at the same time.

If the seat belt is not fastened by the driver or front passenger during the next approx. 2 minutes, the warning signal is deactivated and the warning light  illuminates permanently.

Adaptive cruise control (ACC)

 **Read and observe  on page 40 first.**

 illuminates - the ACC delay is not sufficient.

- ▶ Apply the brake.

For more information about the ACC system » [page 236](#).



Power steering/steering lock (KESY system)

 **Read and observe**  **on page 40 first.**

Fault in the power steering

 lights up – this indicates a complete failure of the power steering and the steering assist is no longer working (significantly higher steering forces).

 illuminates - this indicates a partial failure of the power steering and the steering forces may be greater.

- ▶ Switch off the ignition, start the engine again and travel a short distance.
- ▶ If the warning light  does not go off, stop the vehicle,  **do not continue your journey**. Seek help from a specialist garage.
- ▶ If the warning light  does not go off, you can drive on, exercising appropriate caution. Seek assistance from a specialist garage immediately.

Steering lock defect (KESY system)

 flashes

Message: **Steering lock faulty. Stop!**

- ▶ Park the vehicle, and  **stop driving**. After switching off the ignition, it is no longer possible to lock the steering, to activate the electrical components (e.g. Infotainment), to switch on the ignition again and to start the engine. Seek help from a specialist garage.

 flashes

Message: **Steering lock: workshop!**

- ▶ You can drive on, exercising appropriate caution. Seek assistance from a specialist garage immediately.

Steering column lock not unlocked (System KESY)

 flashes

Message: **Steering lock: workshop!**

- ▶ Move the steering wheel slightly back and forth, thereby facilitating unlocking the steering lock.
- ▶ If the steering does also not unlock then, the help of a specialist garage is required.

Disconnecting the vehicle battery

If the vehicle's battery has been disconnected and reconnected, the indicator light  comes on after switching on the ignition.

The warning light should go out after driving a short distance.

If, after the motor is restarted and a short drive, the indicator light does not go out, there is a system error.

- ▶ You can drive on, exercising appropriate caution. Seek assistance from a specialist garage immediately.

Stability Control (ESC)/Traction control (TCS)

 **Read and observe**  **on page 40 first.**

 flashes – the ESC or TCS is currently being activated.

 illuminates – there is an ESC or TCS fault.

- ▶ You can drive on, exercising appropriate caution. Seek assistance from a specialist garage immediately.

If the warning light  comes on after starting the engine, the TCS may be switched off for technical reasons.

- ▶ Switch the ignition off and on again.

If the warning light  does not illuminate after you switch the engine back on, the TCS is fully functional again.

Disconnecting the vehicle battery

If the vehicle's battery has been disconnected and reconnected, the indicator light  comes on after switching on the ignition.

The warning light should go out after driving a short distance.

If, after a short drive, the indicator light does not go out, there is a system error.

- ▶ You can drive on, exercising appropriate caution. Seek assistance from a specialist garage immediately.

For more information on the ESC system » [page 217](#) or TCS system » [page 218](#).

Traction control (TCS) deactivated

 Read and observe  on page 40 first.

 illuminates – the TCS system is disabled.

Anti-lock braking system (ABS)





 Read and observe  on page 40 first.

 lights up – there is an ABS fault.

The vehicle will only be braked by the normal brake system without the ABS.

► You can drive on, exercising appropriate caution. Seek assistance from a specialist garage immediately.

WARNING

- If warning light  illuminates simultaneously with warning light 
 - » page 40,  Brake system ,  **stop driving!** Seek help from a specialist garage.
- A fault to the ABS system or the braking system can increase the vehicle's braking distance – risk of accident!

Rear fog light

 Read and observe  on page 40 first.

 illuminates - the rear fog light is switched on.

Emission control system

 Read and observe  on page 40 first.

 illuminates – there is a fault in the emission control system. The system makes it possible to drive on in emergency mode – there may be a noticeable reduction in engine performance.

► You can drive on, exercising appropriate caution. Seek assistance from a specialist garage immediately.

Preheating unit (diesel)

 Read and observe  on page 40 first.

 flashes – there is a fault in the engine management system. The system makes possible operation emergency mode - there may be a noticeable reduction in engine performance.

There is a fault in the glow plug system if the warning light  does not come on or illuminates continuously.

► You can drive on, exercising appropriate caution. Seek assistance from a specialist garage immediately.

EPC warning light (petrol)

 Read and observe  on page 40 first.

EPC lights up – there is a fault in the engine management system. The system makes it possible to drive on in emergency mode – there may be a noticeable reduction in engine performance.

► You can drive on, exercising appropriate caution. Seek assistance from a specialist garage immediately.

Safety systems

 Read and observe  on page 40 first.

System fault

 illuminates

Message: Error: airbag

► Seek help from a specialist garage.

The front passenger airbag has been disabled with the key switch

 illuminates for 4 seconds after the ignition has been switched on.

One of the airbags or a belt tensioner has been disabled by the diagnostic tool

 lights up for around 4 seconds after the ignition is switched on and then flashes for approximately 12 seconds

Message: Airbag/ belt tensioner deactivated. ►

ProActive passenger protection

 illuminates and the following message is shown in the information cluster display

Message: **Proactive passenger protection unavailable.**
or
ProActive passenger protection: funct. restricted.

The seat belt for the driver and front passenger needs to be replaced.

► Seek help from a specialist garage.

WARNING

When a fault in the airbag system occurs, there is a risk of the system not being triggered in the event of an accident. Therefore, this must be checked immediately by a specialized garage.

Tyre pressure

 **Read and observe  on page 40 first.**

Change of tyre pressure values

 illuminates - there was a pressure change in one of the tyres.

- Immediately reduce speed and avoid sudden steering and braking manoeuvres.
- Stop the vehicle, turn the ignition off and check the tyres and their inflation pressures » [page 277](#).
- Correct the tyre pressure if necessary or replace the affected wheel » [page 283](#) or use the repair kit » [page 286](#).
- Save the tyre pressure values in the system » [page 253](#).

System fault

 flashes for approximately 1 minute and remains lit – there may be a fault in the tyre pressure monitoring system.

► Stop the vehicle, turn the ignition off and start the engine again.

If the warning light  flashes after starting the engine again, there is a system error.

► You can drive on, exercising appropriate caution. Seek assistance from a specialist garage immediately.

Disconnecting the vehicle battery

If the vehicle's battery has been disconnected and reconnected, the indicator light  comes on after switching on the ignition.

The warning light should go out after driving a short distance.

If, after a short drive, the indicator light does not go out, there is a system error.

► You can drive on, exercising appropriate caution. Seek assistance from a specialist garage immediately.

Other incidents

The illumination of the warning light  can have the following reasons.

- The vehicle is loaded on one side. Distribute the load evenly.
- The wheels of one axle are loaded more heavily (e.g. when towing a trailer or when driving uphill or downhill).
- Snow chains are mounted.
- A wheel has been changed.

CAUTION

Under certain circumstances (e.g. sporty style of driving, wintry or unpaved roads) the warning light  can be delayed or does not light up at all.

Brake linings

 **Read and observe  on page 40 first.**

 illuminates - the brake pads are worn.

► It is possible to continue driving with due caution. Seek assistance from a specialist garage immediately.

Fuel reserve

 **Read and observe  on page 40 first.**

 illuminates – the fuel level in the fuel tank is at the reserve level (approximately 6 litres).



► Fill up with fuel » [page 265](#).

Note

The text in the display goes out after refuelling and driving a short distance.

Lane Departure Warning (Lane Assist)

 Read and observe  on page 40 first.

The warning lights   indicates the state of the Lane Assist system.

More information about the Lane Assist System » [page 247](#).

Turn signal system

 Read and observe  on page 40 first.

 flashes - the left turn signal is switched on.

 flashes – the right turn signal is turned on.

If there is a fault in the turn signal system, the warning light flashes at twice its normal rate (does not apply when towing).

When the hazard warning light system is switched on, this will cause all of the turn signal lights as well as both warning lights to flash.

Trailer turn signal lights

 Read and observe  on page 40 first.

 flashes - the trailer turn signals are switched on.

If a trailer is hitched and the warning light  is not flashing, one of the trailer turn signal lights has failed.

► Check the trailer bulbs.

Fog lights

 Read and observe  on page 40 first.

 illuminates - the fog lights are switched on.

Speed regulating system/speed limiter

 Read and observe  on page 40 first.

 illuminates - the vehicle speed is limited by the speed regulating system and/or the adaptive cruise control or by the speed limiter.

 flashes - the speed set with the speed limiter has been exceeded.

Brake pedal (automatic gearbox)

 Read and observe  on page 40 first.

 lights up – apply the brake.

Auto Hold function

 Read and observe  on page 40 first.

 illuminates - the Auto Hold function is activated.

For more information about the Auto-Hold Function » [page 209](#).

Main beam

 Read and observe  on page 40 first.

 illuminates - the main beam or headlight flasher is switched on.

Automatic gearbox

 Read and observe  on page 40 first.

Gearbox overheated

  illuminates

Message: Gearbox overheated. You can drive on.

Transmission overheated. You can drive on, exercising appropriate caution.

  illuminates

Message: Gearbox overheated. Stop! Log book!

►  **Do not drive the vehicle!** Stop the vehicle and turn off the engine.

You can continue your journey as soon as the warning light disappears.

► If the warning light does not go off,  **stop driving!** Seek help from a specialist garage.

Transmission problem

  illuminates

Message: Gearbox faulty. Stop the vehicle safely!

  illuminates

Message: **Gearbox in emergency mode. No reverse gear.**
Error: gearbox. Speed is limited.

- ▶ You can drive on, exercising appropriate caution. Seek assistance from a specialist garage immediately.

Rear seat belt warning light

 **Read and observe  on page 40 first.**

 illuminates – a rear seat belt is not fastened.

 illuminates – a rear seat belt is fastened.



When the seat belt is fastened/unfastened, the particular light lights up briefly and indicates the current belt status!

Generator

 **Read and observe  on page 40 first.**

 illuminates - the battery is not being charged while the engine is running.

CAUTION

If in addition to the light  the light  lights up while driving,  **stop driving** - There is a risk of engine damage! Switch off the engine and seek assistance from a specialist garage.

Coolant

 **Read and observe  on page 40 first.**

Coolant level too low



  illuminates

Message: **Please check the coolant level. Log book!**

- ▶ Stop the vehicle, switch off the engine and let it cool.
- ▶ Check the coolant level » [page 272](#).

If the coolant level is within the specified range and the warning light  lights up again, then there may be a malfunction of the cooling fan.

- ▶ Switch off the ignition.
- ▶ Check the fuse for the radiator fan, replace if necessary.

If the coolant level and fan fuse are both OK but the warning light  lights up again,  **stop driving!**

- ▶ Seek help from a specialist garage.

Coolant temperature too high

  illuminates

Message: **Engine overheat. Stop! Observe log book.**

- ▶ Stop the vehicle, switch off the engine and let it cool.
- ▶ Continue your journey only after the warning light  has disappeared.

Engine oil pressure

 **Read and observe  on page 40 first.**

  flashes - the engine oil pressure is too low.

- ▶ Stop the vehicle, switch off the engine, and check the engine oil level.
- ▶ Even if the oil level is correct,  **do not drive any further** if the warning light is flashing! Also do not leave the engine running at an idling speed.
- ▶ Seek help from a specialist garage.

CAUTION

If it is not possible to top up with engine oil,  **stop driving** - there is a risk of engine damage! Switch off the engine and seek assistance from a specialist garage.

Engine oil level

 **Read and observe  on page 40 first.**

Engine oil level too low

  illuminates

Message: **Please add engine oil.**

- ▶ Stop the vehicle, switch off the engine, and check the engine oil level, top up if necessary. ▶

The warning light will go out if the bonnet is left open for more than 30 seconds. If the engine oil is not replenished, the warning light will come on again after driving about 100 km.

Engine oil level too high

  illuminates

Message: Please reduce oil level.

- ▶ Stop the vehicle, switch off the engine, and check the engine oil level.
- ▶ In the event of an oil level which is too high, you can drive on, exercising appropriate caution. Seek assistance from a specialist garage immediately.

Fault on the engine oil level sensor

  illuminates

Message: Oil sensor: please visit workshop.

- ▶ Immediately drive to the nearest specialist garage with appropriate caution.

CAUTION

If it is not possible to top up with engine oil,  **stop driving** - there is a risk of engine damage! Switch off the engine and seek assistance from a specialist garage.

AdBlue® level II low (diesel engine)

 Read and observe  on page 40 first.

 Illuminates - AdBlue® level too low.

- ▶ Replenish Add AdBlue® » page 267.

AdBlue® error (diesel engine)

 Read and observe  on page 40 first.

 illuminates - there is a fault in the AdBlue® system.

- ▶ Seek help from a specialist garage.

Lamp failure

 Read and observe  on page 40 first.

  illuminates - one of the lamps is faulty.

A message will appear in the display about the affected lamp.

Display when the light is switched off

 Read and observe  on page 40 first.

Applies to vehicles with the digital instrument cluster.

 lit - no light is on.

Message: Please turn on the light.

Particulate filter

 Read and observe  on page 40 first.

The particulate filter separates and burns the soot particles from the exhaust.

  illuminates - the filter is clogged with soot.

To clean the filter, if allowed by the traffic conditions » , you should drive at a speed between 50-120 km/h in the recommended gear.

If the filter is properly cleaned, the warning light  extinguishes.



If the indicator light  does not go out within 30 minutes, the filter was not cleaned.

- ▶ Immediately drive to the nearest specialist garage with appropriate caution.

WARNING

- Always adjust the speed and driving style to the actual weather, road, terrain and traffic conditions.
- The particulate filter reaches very high temperatures - there is a fire hazard and serious injury could be caused. Therefore, never stop the vehicle at places where the underside of your vehicle can come into contact with flammable materials, such as dry grass, undergrowth, leaves, spilled fuel or the like.

CAUTION

- As long as the warning light  illuminates, one must take into account an increased fuel consumption and a power reduction of the engine.
- As long as the indicator light  is lit, the START-STOP function is not available.

Note

We encourage you to avoid constant short journeys. This supports the correct function of the particulate filter.

Windscreen washer fluid level

 **Read and observe  on page 40 first.**

  illuminates - the windscreen washer fluid level is too low.

► Top up the windscreen washer fluid » [page 271](#).



Headlight assistant

 **Read and observe  on page 40 first.**

 Illuminates – the headlight assistant is activated » [page 74](#), *Headlight Assist (Light Assist / Dynamic Light Assist)*.

START-STOP system

 **Read and observe  on page 40 first.**

The warning lights   indicates the state of the START STOP system » [page 206](#).

Display of a low temperature

 **Read and observe  on page 40 first.**

 illuminates - the outside temperature is below +4 °C.

WARNING

Even at temperatures around +4 °C, black ice may still be on the road surface! Do not only rely upon the information given on the outside temperature display that there is no ice on the road.

Water in the fuel filter (diesel engine)

 **Read and observe  on page 40 first.**

The fuel filter with water separator, filters out dirt and water from the fuel.

If too much water is present in the separator, the following information appears on the instrument cluster display.



  illuminates

Message: **Water in fuel filter. Log book!**

► You can drive on, exercising appropriate caution. Seek assistance from a specialist garage immediately.

Adaptive Cruise Control (ACC)

 **Read and observe  on page 40 first.**

The warning lights   ! indicate the condition of the ACC system » [page 236](#).

Front Assist

 **Read and observe  on page 40 first.**

 illuminates – the safe distance to the vehicle in front is below the minimum.

Information on the Front Assist system » [page 242](#).

front Assist

 **Read and observe  on page 40 first.**

  illuminates

► Front Assist has recognised the risk of a collision or automatically triggered an emergency braking manoeuvre » [page 242](#).

► An automatic deactivation of Front Assist took place when activating ESC Sport » [page 217](#) and when deactivating the ASR » [page 218](#).

► Front Assist is not available » [page 244](#).

 Illuminates with the lettering OFF  - Front Assist is deactivated » [page 243](#).

emergency call

 **Read and observe  on page 40 first.**

  lights up – there is a fault in the emergency call system.

► Seek help from a specialist garage.

Economy mode

 Read and observe  on page 40 first.

 illuminates - the vehicle is in economy mode due to the intervention of the active cylinder management or due to the neutral position of the automatic gearbox.

Adaptive chassis (DCC)

 Read and observe  on page 40 first.

  illuminates - there is a DCC fault.

► It is possible to continue driving with due caution. Seek assistance from a specialist garage immediately.

Service

 Read and observe  on page 40 first.

 illuminates - note regarding a due service appointment » page 55, *Displaying the distance and days until the next service interval.*

Information system

Driver information system

Display in the instrument cluster

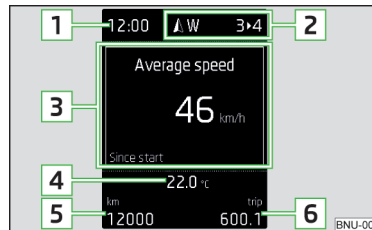

Fig. 38
Display overview

Depending on the vehicle's equipment, the information system uses the display in the instrument cluster to provide the following information » Fig. 38.

- 1 Time / symbols of the Infotainment voice control
- 2 Engaged gear / gear recommendation
Selector lever positions for the automatic gearbox
Warning lights of the START-STOP system
Compass display
Detected traffic signs
- 3 Driving data (multifunction display)
Warning lights
Information messages
Door alarm
Eco tips
Service interval display
- 4 Outside temperature
- 5 Cruise control / speed limiter
Total distance travelled
- 6 Distance travelled by resetting the memory (trip)

Door, luggage compartment and bonnet alarm

When the door or luggage compartment / bonnet is open, a graphic warning appears in the display. ►

An acoustic signal will also sound if you drive the vehicle above 6 km/h when a door is open.

Reset counter for distance travelled (trip)

› Press button **A** » Fig. 39 on page 49.

Setting the time

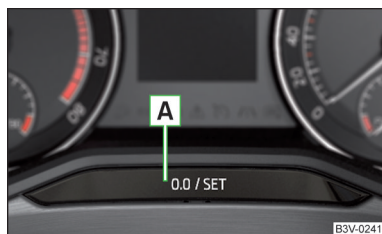

Fig. 39
Button in the instrument cluster

Set the time using the button in the instrument cluster

- › Switch on the ignition.
- › Press and hold the button **A** » Fig. 39 until the time is shown in the display.
- › Release the button **A** and the system switches to the hour setting function.
- › Press the button **A** again and set the hours.
- › Wait 4 seconds, the system switches to the minutes setting.
- › Press the button **A** again and set the minutes.
- › Wait 4 seconds, the system switches to the initial setting.

Gear recommendation

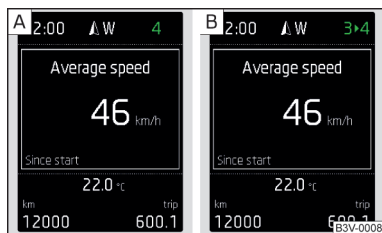

Fig. 40
Information on the selected gear / Gear recommendation

A suitable engaged gear or, where appropriate, a recommended gear is displayed, with the aim of conserving the life of the engine and increasing driving efficiency.

Display » Fig. 40

- A** Optimal gear engaged
- B** Gear recommendation (e.g. 3 ► 4 means that it is advantageous to switch from 3rd to 4th gear)

For vehicles with automatic transmission the recommended gear will be shown provided the mode for manual switching (Tiptronic) is selected.

! WARNING

The driver is always responsible for selecting the correct gear in different driving situations, such as overtaking.

Vehicle condition

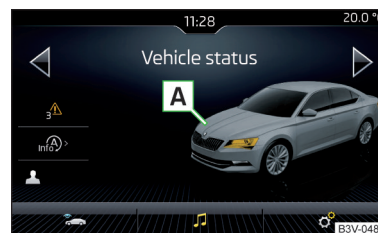









Fig. 41
Vehicle condition

Certain functions and conditions of individual vehicle systems are checked continuously when the ignition is switched on. If there is a fault in the system, the following message will appear in the display of the instrument cluster.

While the operational faults remain unrectified, the messages are always indicated again. After the message is displayed for the first time, the warning lights  (danger) or  (warning) continue to be displayed.

The vehicle condition can be displayed in Infotainment in the menu   →  → Vehicle status.

In the screen, information regarding vehicle condition or function of the tyre pressure monitor is displayed.

- › Using the function surfaces   select the menu item *Vehicle status*.

Function surfaces and screen display » Fig. 41

- A** Vehicle representation (the zones of the vehicle are shown in different colours, corresponding to any warning messages that occur. The warning messages are displayed once you touch the “vehicle”)
- ✓/⚠ No message/warning messages relating to vehicle status and the number (if there is only one message, one warning message text is displayed)
- inf> Display information about the status of the START-STOP system
 - 🔊/🔇 Activation / deactivation of notes relating to START-STOP-System messages in another screen display

Display information on sporty driving in Infotainment

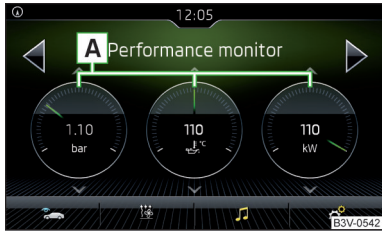

Fig. 42
Infotainment display

The display of data on sporty driving is used to evaluate current motor values.

- To **display** in the Infotainment menu (CAR) tap on function surface → **Sports**.
- Using the functional surfaces <> the *Information sports* the menu item is chosen.

A swipe of the finger vertically across the screen allows three of the following displays **A** to be shown » Fig. 42.

- ▶ Boost pressure display
- ▶ Acceleration display
- ▶ Power display
- ▶ Coolant temperature display
- ▶ Oil temperature display

laptimer Show (stopwatch) in the infotainment

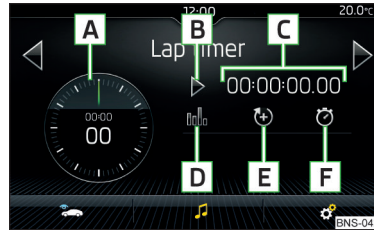

Fig. 43
Infotainment display

- To **display** tap in the Infotainment menu (CAR) tap on function surface → **Sports**.
- Using the functional surfaces choose <> the *laptimer* menu item.

Function surfaces and screen display » Fig. 43

- A** Total time, display of intermediate time for 5 s
- B** Start/stop the time measurement
- C** Current lap time
- D** Statistics - Evaluation / Reset of measured times
- E** New lap - start measuring the next lap time
- F** interim

Stop timing

After the termination of the time measurement, the following functional areas for the completion of the measurement are displayed on the screen.

- The current lap time is saved
- The current lap time is not saved

! WARNING

- Concentrate fully at all times on your driving! As the driver you are fully responsible for the operation of your vehicle.
- Only use the **Lap timer** when you are in any traffic situation where you have full control of the vehicle.

i Note

If the measured times are not reset, then these are stored even after turning off the ignition.

Operation of the information system

Operation using the control lever

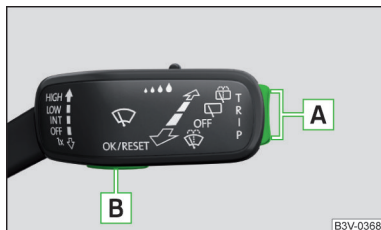

Fig. 44
Buttons on the operating lever

Operating the multifunction display

- A** Press (up or down) - select data / set values
- B** Press - display / confirm indication

Operation of the display menus

- A** Press (up or down) - move to the selected menu
- Hold** (up or down) - display main menu
- B** Press - confirm selected menu item

Operation using the multifunctional steering wheel



Fig. 45 Buttons/dials: on the multifunction steering wheel

Buttons/dials on the multifunction steering wheel

- Switch on/off voice control
- A** Turn - sets the volume
- Press - sound on / off

- ▷ Skip to next track/station
- ◁ Switch to previous track/station
- Display the assistance systems menu
- VIEW** Depending on equipment:
 - ▷ Operating a digital instrument cluster » [page 38](#)
 - ▷ Show previous menu (if one has been selected) / display Telephone menu

Operating the multifunction display

- B** Turn - select data / set values
- Press - display / confirm indication

Operation of the display menus

- Hold** - display main menu
- Press - return to a previous level in the menu
- B** Turn - move in the selected menu
- Press - confirm selected menu item

Driving data (Multifunction display)

Introduction

The driving data display is only possible with the ignition switched on.

The units can be adjusted in Infotainment in the menu → → Units.

The journey data can be set/reset in Infotainment in the menu → → Instrument cluster.

Note

The setting of the information display is stored in the active user account personalisation » [page 55](#).

Information Overview

Overview of driving data (depending on the vehicle equipment).

Range - drive distance in km which can be covered with the existing tank capacity and with the same driving style. If you drive more efficiently this value can increase. ▶

AdBlue® range - drive distance in km which can be covered with the existing AdBlue® tank capacity and with the same driving style. If you drive more efficiently this value can increase. When the system detects that AdBlue® can be refilled, an indication of the minimum and maximum AdBlue® refilling quantity appears.

Average fuel consumption - is calculated continuously since the last time the memory was deleted. After erasing the memory, no data will appear for the first 100 m driven.

Current fuel consumption - when the vehicle is stationary or slowly moving, the fuel consumption is displayed in l/h (--,- km/l appears on models for some countries).

Oil temperature - if the temperature is lower than 50 °C or if there is a fault in the system for checking the oil temperature, the — symbols are displayed.

Warning when the preset speed is exceeded - allows the setting of a speed limit where, if exceeded, an acoustic warning signal and a warning message appears on the display of the instrument cluster.

Dynamic Road Sign Display - traffic signs display » [page 250](#), *Traffic sign recognition*.

Current speed - digital speedometer.

Average speed - is calculated continuously since the last time the memory was deleted. After erasing the memory, no data will appear for the first 300 m driven.

Driving route - distance driven since the last time the memory was deleted.

Driving time - driving time since the last time the memory was deleted.

Conv. consumers - information about the total consumption of the comfort consumers in l/h and a list of three consumers (e.g. air conditioning etc.), which have the largest share of fuel consumption.

Infotainment display

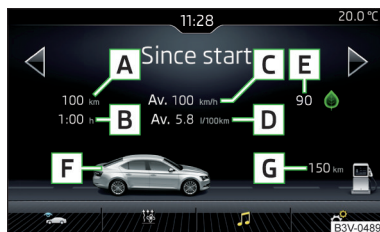

Fig. 46
Journey data

› In Infotainment in the menu tap on function surface → Tap Journey data.

Screen display » Fig. 46

- A** Distance travelled
- B** Driving time
- C** Average speed
- D** Average fuel consumption
- E** Transit point rating (DriveGreenFunction)
- F** Graphic fuel level display (if the estimated range is less than 300 km, the vehicle starts to approach the symbol)
- G** Approximate range

Use the function surfaces <|> to select one of the following presets.

- ▶ *Since start* - Driving data for the individual trip
- ▶ *Long-term* - Long-term driving data
- ▶ *Since refuel* - Data since refuelling

Warning when exceeding the set speed

The system offers the possibility to set a speed limit beyond which an acoustic warning signal will sound and the following warning message appears in the display of the instrument cluster.

Adjust the speed limit while the vehicle is stationary

- › Select the menu item **Warning at** and confirm.
- › Set the desired speed limit in 5 km/h steps.
- › Confirm the set value, or wait several seconds; your settings will be saved automatically.

Adjusting the speed limit while the vehicle is moving

- › Select the menu item **Warning at** and confirm.
- › Drive at the desired speed.
- › Confirm the current speed as the speed limit.

The set speed limit can be manually adjusted later if needed.

Reset the speed limit

- › Select the menu item **Warning at** and confirm.
- › By confirming the stored value, the speed limit is reset.

The speed limit set mode is stored even after the ignition is switched off and on. After a gap between driving exceeding 2 hours, the pre-set speed limit is deactivated.

Memory



Fig. 47
Memory display

The system saves the data in the three memories described below which are displayed at the position **A** » Fig. 47.

Since start

In the memory, driving data is saved for the time between switching on and switching off the ignition. New data will also flow into the calculation of the current driving information if the trip is continued **within 2 hours** after switching off the ignition.

If the trip is interrupted for **more than 2 hours**, the memory is automatically erased.

Long-term

The memory gathers driving data from any number of individual journeys up to a total of 99 hours and 59 minutes driving time or 9999 kilometres driven.

The indicator is automatically set back to zero if one of the indicated values is exceeded.

Since refuel

The driving data is stored in the memory since the last fuel refuelling.

The memory is erased automatically the next time you fill up.

- › For the **Storage choice**, repeatedly confirm the selected indication and select the desired memory.
- › For **Deleting the memory** for the selected information, hold down the button confirming the specification.

The following driving data are stored.

- ▶ Average fuel consumption
- ▶ Distance travelled
- ▶ Average speed
- ▶ Driving time

i Note

Disconnecting the vehicle battery will delete all memory data.

Menus in the display of the instrument cluster

Introduction

The instrument cluster display is a user interface which, depending on the equipment configuration, provides information about the Infotainment, the multifunction display, the assistance systems etc.

The menus with details can be operated and displayed using the buttons on the operating lever or the multifunction steering wheel » page 51.

Main menu items (depending on vehicle equipment)

- Driving data » page 51
- Assist systems » page 54
- Navigation » page 54
- Audio » page 54
- Telephone » page 54;
- Vehicle » page 49

i Note

- If warning messages are displayed, these messages must first be confirmed to access the main menu.
- The display language can also be set in Infotainment » [page 137, Setting the Infotainment language](#) and » [page 144, Setting the Infotainment language](#).

Navigation menu item

The following information is displayed in the **Navigation** menu item.

- ▶ Driving recommendations
- ▶ Compass
- ▶ Last destinations

audio menu item

E.g. the following information is displayed in the **Audio** menu item.

Radio



- ▶ Currently playing station (name/frequency).
- ▶ The selected frequency range (e.g. FM) optionally with the number of the station button (e.g. FM3), if the station is stored in the memory list.
- ▶ List of available stations (if more than 5 stations can be received).
- ▶ TP traffic announcements.

Media



- ▶ Name of the track being played, if necessary, further information regarding title (e.g. artist, album name), if this information is stored as a so called ID3 tag on the audio source.

Telephone menu item

The call list with the following symbols is displayed in the **Telephone** menu item.

-  Incoming call
-  Outgoing call
-  Missed call

Symbols in the display

-  Telephone battery charge (this function is only supported by some mobile phones)
-  Signal strength (this function is only supported by some mobile phones)
-  A telephone connected to the Infotainment system

 Missed calls (if there are several missed calls, the number of calls is shown next to the symbol)

 Switch-off microphone

Apple CarPlay

An external device connected to the Infotainment system via Apple CarPlay can be operated via the multifunction steering wheel as well as via menus in the instrument cluster display.

The following symbols are displayed in the **Telephone** menu option.

 Answer the incoming call

 Reject incoming call / end call

 Activate / deactivate microphone (applies for the infotainment Swing)

Assist systems menu item

The following systems are activated/deactivated in the **Assist systems** menu item.

- ▶ Lane Assist
- ▶ Front Assist
- ▶ Assist system for blind spot monitoring
- ▶ Rear Traffic Alert

Service intervals

Introduction

Compliance with the service intervals is of crucial importance for the service life and value retention of the vehicle. Never exceed the service date.

The specialist garage will inform you about the type of service interval, the option to change it, and the service scope.

The service interval display in the display of the instrument cluster will notify you when a service is due.

Proof of service

A specialist garage will confirm the corresponding service record in the service information system called Digital Service Plan.

We recommend that you always print out the respective service record. ▶

i Note

The customer is responsible for covering the cost of all services including changing or replenishing the oil, even during the warranty period, unless stated otherwise in the ŠKODA AUTO warranty terms or other binding agreements.

Displaying the distance and days until the next service interval

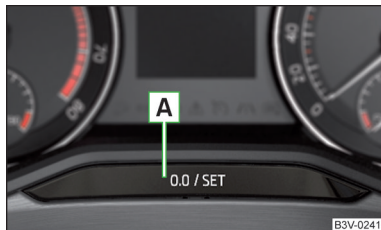

Fig. 48
Button in the instrument cluster

The details regarding the remaining kilometres or days until the next scheduled service can be displayed in Infotainment in the menu → **Events** or with the button in the instrument cluster.

Use the key to display

- › Switch on the ignition.
- › Press and hold the button **A** » Fig. 48 until the **Service** menu item is shown in the display.
- › Release the button **A**.

In the display, the symbol appears for 4 seconds along with the following message for the kilometres or days to the next service appointment.

Service messages

Before the next service date has been reached, the symbol as well as a message about the mileage or days until the next service event appears in the display after the ignition is switched on.

Once the service interval **is reached**, the symbol appears in the display after the ignition is switched on, together with the message:

Resetting the service interval display

Have the display reset by a specialist garage.

We recommend that you do not reset the service interval display yourself. Incorrectly setting the service interval display can cause problems to the vehicle.

Variable service interval

For vehicles with variable service intervals, after resetting the oil change service display in a specialist garage, the values of the new service interval are displayed, which are based on the previous operating conditions of the vehicle.

These values are then continuously matched according to the actual operating conditions of the vehicle.

Personalization

Introduction

Thanks to the personalisation, more drivers have the opportunity to use a vehicle with individually set system functions by means of a user account which is assigned to the respective vehicle key.

! WARNING

Make all adjustments when the vehicle is stationary - otherwise there is the risk of accident!

Operating principle

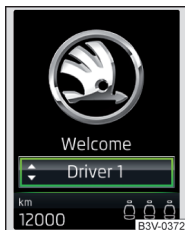

Fig. 49
Switching to a different user account

Read and observe on page 55 first.

After unlocking the vehicle and opening the driver's door, all the personalised functions are adjusted according to the user account that is assigned to the key which was used to unlock the vehicle.

Any change to the set personalised functions is automatically stored in the active user account.

As part of the personalisation, three default user accounts as well as a **Guestaccount** are provided.

Switch to a different user account

You can switch to a different user account in the instrument cluster display [» Fig. 49](#) within 10 seconds after turning on the ignition.

An account can be changed at a later time in Infotainment in the menu → → **Vehicle status** → (if the **Tyre Pressure Monitoring System** is displayed first of all, then use the arrow or switch to **Vehicle status**).

If an account is selected in which not all of the points required by the system are set, a configuration wizard can be automatically displayed on the Infotainment screen [» page 132](#).

Electrically adjustable driver's seat (referred to only as seat in the following)

The seated position adjustment is carried out in the following cases.

- ▶ After unlocking the vehicle and opening the driver's door (in this case: before the vehicle was locked, an account with a certain seat setting was selected. After vehicle unlocking, an account is activated to which a different seat setting is assigned).
- ▶ After switching to a different user account and at a speed less than 5 km/h.

The seat adjustment can be terminated as follows.

- ▶ By tapping on the function surface **Cancel** on the Infotainment screen.
- ▶ By pressing any key on the seat [» page 85](#).

Note

Vehicles with the personalisation function are provided with three vehicle keys.

Overview of some personalized functions

Read and observe on page 55 first.

- ▶ Setting the electrically adjustable driver's seat.
- ▶ Exterior mirror adjustment.
- ▶ Driving mode - setting the **individual mode**
- ▶ Assistance systems - Lane Assist, parking aid (Park Pilot).
- ▶ Light - ambient lighting, convenience turn signal, COMING HOME / LEAVING HOME.
- ▶ Climatronic - temperature in each individual area, fan speed, recirculation mode.
- ▶ Infotainment settings - brightness level of the screen, keyboard arrangement.
- ▶ Radio - sound settings, station sorting.
- ▶ Media - shuffle / repeat title, selected video format.
- ▶ Voice control - acoustic signals.
- ▶ Navigation - home address, alternative routes, recommended route, reminder of the lack of fuel.

Note

The scope of the personalisation functions is dependent on the type of Infotainment package.

Setting the personalization

Read and observe on page 55 first.

- ▶ In Infotainment in the menu tap on function surface → **Personalisation**.

The following menu items are displayed.

Personalisation

Active - activate/deactivate the personalisation

Select a user account

A list of user accounts with the option to manage user accounts and to switch to another account.

- > - Account management with the following options:
 - **Rename user account** - rename the user account (not applicable to the **Guest** account)
 - **Copy settings to another account** - copy the settings of an active user account to another user account
 - **Reset user account** - reset the selected user account to factory settings

Adjusting

- **Key assignment:** - options for assigning the vehicle key to the user account:
 - **Manual** - detected vehicle key must be assigned to the active user account manually
 - **Automatic** - detected vehicle key automatically assigned to a different account of the active user account
- **Assign vehicle key to current user account** - manual assignment of the detected vehicle key to the active user account - follow the instructions on the Infotainment screen
- **Reset all** - reset the personalisation and the user accounts to factory settings

Unlocking and opening

Unlocking and locking

Introduction

The vehicle is equipped with a central locking system which makes it possible to unlock / lock **all** the doors, the fuel filler flap and boot lid simultaneously.

The door unlocking can be adjusted individually » [page 60](#).

The **unlocking** of the vehicle is displayed by the turn signal lights flashing twice.

If you unlock the vehicle and do not open a door or the boot lid within the next 45 seconds, the vehicle will lock again automatically.

The **locking** of the vehicle is displayed by the turn signal lights flashing once.

If the driver's door has been opened, the vehicle cannot be locked.

If the doors or the boot lid remain open after the vehicle has been locked, the turn signal lights do not flash until they have been closed.

WARNING

- Never leave the key in the vehicle when you exit the vehicle. Unauthorized persons (e.g. children) could lock the car, turn on the ignition or start the engine - there is a danger of injury and accidents!
- When leaving the vehicle, never leave people who are not completely independent, such as children, unattended in the vehicle. These individuals might not be able to leave the vehicle on their own or to help themselves. Can be fatal at very high or very low temperatures!

CAUTION

- Each key contains electronic components; therefore it must be protected against moisture and severe shocks.
- Keep the keyway clean. Impurities (textile fibres, dust etc.) have a negative effect on the functionality of the locking cylinder and ignition lock.

Unlocking/locking with the remote control key

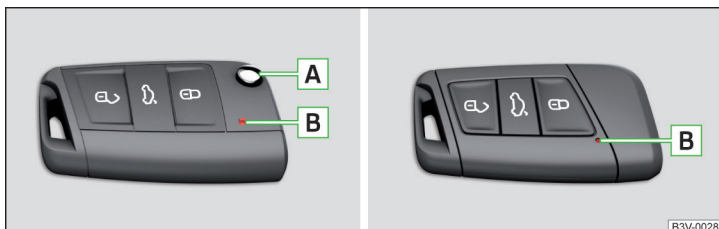

Fig. 50 Key with fold/out key bit/KESSY key

Read and observe **!** and **!** on page 57 first.

Description of the key » Fig. 50

 Unlock button

 Lock button

 Depending on equipment fitted:

- ▶ Unlock/unlatch the boot lid (vehicles fitted with manual folding operation)
- ▶ Open/close/ the boot lid Stop movement of the boot lid (vehicles with electric folding operation)

A Locking button for folding the key bit in/out

B Warning light for the battery charge - if the warning light does not flash when a button on the key is pressed, the battery is discharged.

Unlock/unlatch the boot lid (vehicles fitted with manual folding operation)

By pressing the button , the lid is unlocked.

By holding the button , the lid is unlocked and unlatched (partially open).

If the lid is unlocked or unlatched using the  button, then the lid is automatically locked after closing. The period after which the lid is locked can be set » page 63.

! CAUTION

- The remote control may be affected by signal superposition of transmitters that are in the vicinity of the vehicle.
- The range of the remote control key is about 30 m. The battery must be replaced if the central locking only reacts to the remote control at a distance of less than approximately 3 m away » page 291.

Remove KESSY emergency key

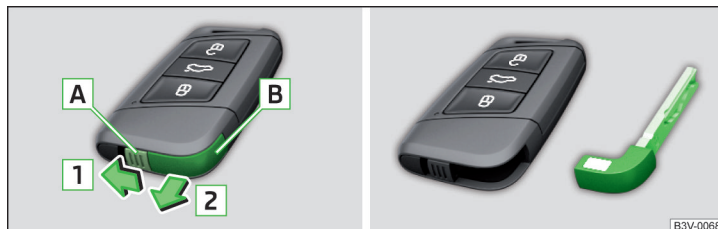

Fig. 51 KESSY key

Read and observe **!** and **!** on page 57 first.

The emergency key is, for example, intended for the operation of the child safety, and for switching off/on the front passenger airbag.

- ▶ Remove retainer tabs **A** in the direction of arrow **1** » Fig. 51.
- ▶ Remove the emergency key **B** in the direction of the arrow **2**.

Locking / unlocking - KESSY

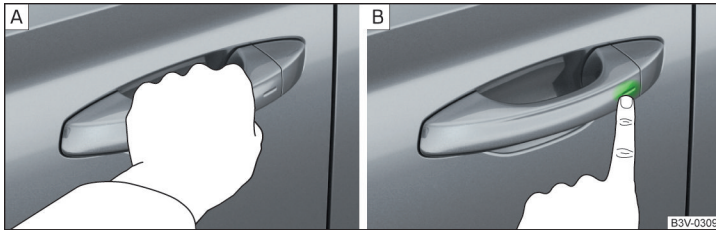

Fig. 52 Vehicle unlocking / vehicle locking

Read and observe **!** and **!** on page 57 first.

The KESSY system (Keyless Entry Start Exit System) enables unlocking and locking of the vehicle without actively using the remote control key.

- Grip the door handle to **unlock** the vehicle » Fig. 52 - [A].
- Touch the sensor on the door handle with your finger to **lock** » Fig. 52 - [B] the vehicle.

When unlocking/locking the vehicle, the key must be at a maximum distance of approximately 1.5 m from the front door handle.

Information on locking

On vehicles fitted with automatic gearbox, the selector lever must be moved into the position **P** before unlocking.

After locking the vehicle, it is not possible to unlock within the next 2 seconds by touching the door handle. This can be used to check whether the vehicle is locked.

Protection against inadvertently locking the key in the vehicle

If one of the doors is closed after the vehicle has been locked and the key with which the vehicle was locked remains in the passenger compartment, the vehicle will be automatically unlocked. After automatically unlocking, the turn signal lights will flash four times. If no door is opened within 45 seconds, the vehicle is automatically locked again.

If the boot lid is closed after locking the vehicle and the key with which the vehicle was locked remains in the luggage compartment, the lid is automatically unlatched (partially opened). After automatically unlocking, the turn signal lights will flash four times. The boot lid **remains unlatched** (partially opened); the other doors remain locked.

! CAUTION

Some types of gloves can affect the unlocking or locking device via the sensors in the door handle.

Deactivating KESSY

Read and observe **!** and **!** on page 57 first.

- Lock the vehicle with the button  on the key.
- Within 5 s, touch the sensor on the door handle with your finger » Fig. 52 on page 59 - [B]. Deactivation is confirmed by a single flash of the direction indicators.
- **To check the deactivation**, wait at least 10 seconds and then pull the door handle. The door must remain locked.

The KESSY system is activated again automatically after the vehicle is unlocked.

Locking/unlocking the vehicle with the central locking button



Fig. 53
Central locking button

Read and observe **!** and **!** on page 57 first.

Conditions for the locking/unlocking using the central locking button.

- ✓ The vehicle is not locked from the outside.
- ✓ All doors are closed.

► **To lock**, press the button  Press » Fig. 53

Locking is displayed in the button by the illumination of the  symbol.

The following applies after locking.

- Opening the doors and the boot lid from the outside is not possible.
- The doors can be unlocked and opened from the inside by a single pull on the opening lever of the respective door.

WARNING

Doors locked from the inside make it difficult for rescuers to get into the vehicle in an emergency – risk to life!

SafeLock

 **Read and observe  and  on page 57 first.**

SafeLock prevents the doors from being opened from inside as well as window operation. This makes it more difficult for anyone to break into the vehicle.

Switching on

SafeLock switches on when the vehicle is locked.

This function is enabled after switching off the ignition with the message **Check safe lock! Log book!** In the instrument cluster display.

Switch-on display

With the activated SafeLock, the warning light in the driver's door flashes for 2 seconds in rapid succession, this then starts to flash at longer intervals.

Switching off

- By locking twice within 2 seconds.
- **or:** by deactivating the interior monitor and the towing protection
» page 62.

The warning light in the driver's door flashes fast for about 2 seconds, goes out and starts to flash at longer intervals after about 30 seconds.

If the vehicle is locked and the safe securing system is switched off, the door can be opened separately from the inside by a single pull on opening lever.



The safelock switches on the next time the vehicle is locked.

WARNING

If the car is locked and the safe securing system activated, no people must remain in the car as it will then not be possible to either unlock a door or open a window from the inside. The locked doors make it more difficult for rescuers to get into the vehicle in an emergency – risk to life!

Individual settings

 **Read and observe  and  on page 57 first.**

The following central locking functions can be set individually in Infotainment in the menu   →  → **Opening and closing.**

All doors

The function allows you to unlock all doors, the boot lid and the fuel filler flap.

Single door

The function allows you to unlock only the driver's door and the fuel filler flap with the radio remote control. KESY allows the unlocking of a single door which is in the vicinity of the key, as well as the fuel filler flap. The other doors and the boot lid are only unlocked once the door handle is unlocked or touched.

Doors on a vehicle side

This function enables you to unlock both doors on the driver's side and the fuel filler flap with the radio remote control unit. KESY allows the unlocking of both doors which are in the vicinity of the key, as well as the fuel filler flap. The other doors and the boot lid are only unlocked once the door handle is unlocked or touched.

Automatic locking/unlocking

This function enables the locking of all doors and the boot lid from a speed of 15 km/h. Opening the doors and the boot lid from the outside is not possible.

The renewed unlocking of the doors and the boot lid is carried out when the ignition key is removed or when the door is opened from inside (depending on the individual setting for the central locking system).

Note

The individual adjustment of the central locking system is stored (depending on the Infotainment type) in the active user account personalisation » page 55.

Open / close door

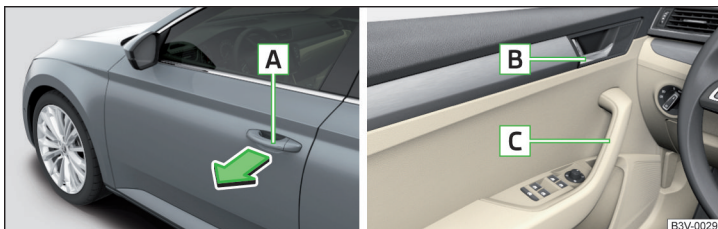

Fig. 54 Door handle/door opening lever

Read and observe **!** and **!** on page 57 first.

- › To **open from outside**, unlock the vehicle and pull the door handle **A** in the direction of arrow » Fig. 54.
- › To **open from inside**, pull on the door opening lever **B** and push the door away from you.
- › To **close from inside**, grip the handle **C** and close the door.

! WARNING

- The door must be closed properly, otherwise it could open whilst driving - risk of death!
- Only open and close the door when no one is located in the opening/closing range - risk of injury!
- Never drive with the doors open - it can be fatal!
- An opened door can close automatically if there is a strong wind or the vehicle is on an incline - risk of injury!

i Note

On vehicles with door warning lights, these illuminate after the door is opened.

Child safety lock

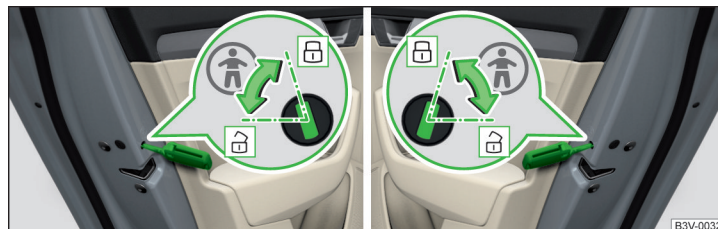

Fig. 55 Rear door: Child safety system switch on / off

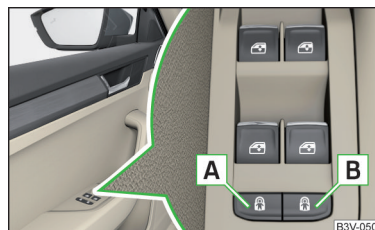



Fig. 56
Child safety lock with electric operation

Read and observe **!** and **!** on page 57 first.

The child safety lock can be operated manually or electrically depending on equipment.

The child safety lock prevents the rear door from being opened from the inside. The door can only be opened from the outside.

Manually controlled parental settings

- › To **switch on**, turn the parental control with the vehicle key in position  » Fig. 55.
- › To **switch off**, turn the parental control with the vehicle key in position .

Child safety lock with electric operation

- › To **switch on/off** the child safety lock in the **left** rear door, press the button **A** in the driver's door » Fig. 56.
- › To **switch on/off** the child safety lock in the **right** rear door, press button **B** in the driver's door.

Locking is displayed in the button by the illumination of the symbol .

When with electric operation in addition to the electric window is blocked in the respective door.

Malfunctions

 **Read and observe  and  on page 57 first.**

Synchronising the remote control

If the buttons on the remote control key have been operated several times beyond the effective range of the system or the battery in the remote control key has been replaced and the vehicle cannot be unlocked using the remote control, the key must be synchronised.

- ▶ Press any button on the remote control key.
- ▶ Unlock the door with the key in the lock cylinder within 1 minute of pressing the button.

Fault with the central locking

If the warning light in the driver's door initially flashes quickly for around 2 seconds, and then illuminates for 30 seconds without interruption before flashing again slowly, you will need to seek the assistance of a specialist garage.

A fault in the central locking system means the vehicle doors and the boot lid cannot be emergency locked or emergency unlocked» [page 293](#).

Failure of the system KESSY

If there is a fault in the KESSY system, the appropriate error message is displayed in the instrument cluster.

Low voltage of the key battery

If the voltage of the key battery is too low, a message appears in the display of the instrument cluster referring to the need to replace the battery. Replace the battery » [page 291](#).

Anti-theft alarm system

Introduction

The alarm system triggers audible and visual signals if an attempt is made to break into the vehicle (hereafter referred to as alarm).

The alarm system is activated automatically approximately 30 seconds after the vehicle is locked. This is automatically disabled after release.

CAUTION

Before leaving the vehicle, it must be checked that all of the windows, doors and the sliding/tilting roof are locked in order to ensure the full functionality of the anti-theft alarm system.

Note

The alarm system has its own power source, service life of which is 5 years. In order to ensure functionality of the alarm system, we recommend that you get the alarm checked after this time by a specialist garage.

Alarm trigger

 **Read and observe  on page 62 first.**

The alarm is triggered when one of the following unauthorised actions is activated on the vehicle with an activated warning system.

- ▶ Opening the bonnet.
- ▶ Opening the boot lid.
- ▶ Opening the doors.
- ▶ Manipulation of the ignition lock.
- ▶ Towing the vehicle.
- ▶ Movement in the vehicle.
- ▶ Sudden and significant voltage drop of the electrical system.
- ▶ Uncoupling the trailer.

An alarm is triggered also when the driver's door is unlocked and opened by the lock cylinder.

The alarm is switched off by pressing the  button on the key or switching on the ignition.

Interior monitor and towing protection

 **Read and observe  on page 62 first.**

The **interior monitor** detects movements inside the locked vehicle and then triggers the alarm.

The **anti-towing** detects tilts in the locked vehicle and then triggers the alarm. ▶

These functions should be deactivated if there is a possibility that the alarm will be triggered by movements (e.g. by people or animals) within the vehicle interior or if the vehicle has to be transported (e.g. by train or ship) or towed.

Disable both functions once

- ▶ In the infotainment system, in menu → **Open and close**,
- ▶ By locking twice within 2 seconds.

Safelock is switched off during deactivation » [page 60](#).

CAUTION

The opened glasses storage compartment reduces the effectiveness of the interior monitor. To ensure the full functionality of the interior monitor, the glasses storage compartment must always be closed before locking the vehicle.

Manually operated tailgate

Introduction

WARNING

- Never drive with the boot lid open or ajar, as otherwise exhaust gases may get into the interior of the vehicle – risk of poisoning!
- Ensure that the lock is properly engaged after closing the lid. Otherwise, the lid might open suddenly while the vehicle is moving, even if the lid was locked – risk of accident!
- Make sure that when closing the boot lid, no body parts are crushed – there is danger of injury!
- Do not press on the rear window when closing the boot lid, it could crack – risk of injury!

Open/close boot lid

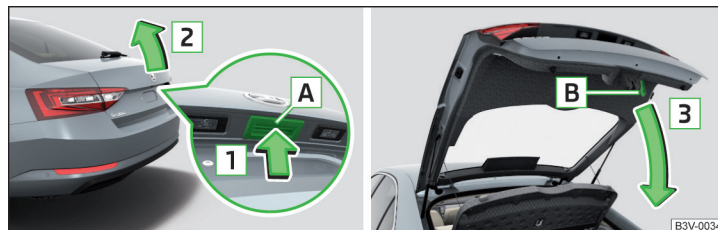

Fig. 57 Opening / closing tailgate

Read and observe on page 63 first.

- ▶ To **open**, press the **A** button in the direction of arrow **1** » Fig. 57.
- ▶ Raise the lid in the direction of the arrow **2**.
- ▶ To **close**, grab the mount **B** and pull in the direction of arrow **3**.

Note

Button **A** » Fig. 57 is deactivated when starting or at a speed of more than 5 km/h. The button is activated again after the vehicle has stopped and a door is opened.

Setting the delayed locking of the boot lid

Read and observe on page 63 first.

If the boot lid is unlocked with the button on the key, the lid is automatically locked again after closing.

The period after which the boot lid is locked automatically can be extended by a specialist garage.

CAUTION

There is a risk of unwanted entry into the vehicle before the boot lid is locked automatically.

Electric boot lid

Introduction

The boot lid (hereinafter as lid) can be operated electrically and manual in the event of an emergency » [page 65](#).

! WARNING

- Ensure that the lock is properly engaged after closing the lid. Otherwise, the lid might open while the vehicle is moving - risk of accident.
- Never drive with the lid open or unlatched, as otherwise exhaust gases may get into the interior of the vehicle – risk of poisoning!
- Only open and close the lid when no one is located in the opening/closing range – risk of injury!
- Make sure that no limbs are caught or crushed when closing the lid - risk of injury!

! CAUTION

- Do not attempt to close the lid manually during electrical motion - there is a risk of damaging the electric lid operation.
- Lock the vehicle before driving through a car wash (or with the central locking button). In some car washes the boot lid might open automatically due to the pressure action of the washing brushes - there is a risk of damage to the vehicle interior, as well as to the objects being transported.

! CAUTION

- Before opening / closing the flap, check that there are no objects in the opening / closing area that could damage the flap, and if there are any objects in the immediate vicinity of the vehicle that could damage the vehicle interior and the objects being transported.
- In certain circumstances, if the lid is loaded (e.g. by a thick layer of snow), the opening process of the lid can be interrupted. Remove the snow from the lid to re-enable the electrical operation.
- If the lid closes automatically (e.g. under load of snow), you will hear an intermittent beep.
- The flap is always to be close before disconnecting the battery.

Description of operation

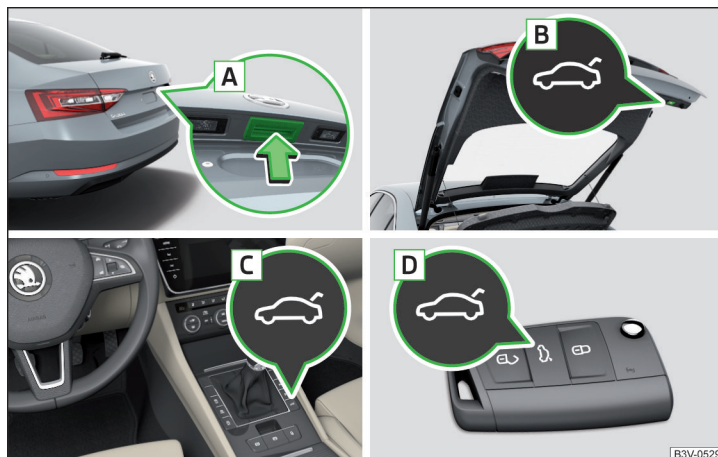

Fig. 58 Lid operation

Read and observe ! and ! on page 64 first.

Ways to open the lid

- ▶ By pressing the handle **A** » [Fig. 58](#).
- ▶ By holding the button **C**.
- ▶ By holding the button **D** on the key.

If the lid hits an obstacle when closing, it stops and an audible signal sounds.

Ways to close the lid

- ▶ By pressing the button **B** » [Fig. 58](#).
- ▶ By holding the button **D** on the key (applies to vehicles with the KESSY keyless unlocking system). The key must be located at a maximum distance of 2 m from the lid.
- ▶ By pressing the handle **A**.
- ▶ By briefly pressing the lid downwards.

If the flap meets an obstacle when it is closed, it stops, an acoustic signal sounds and the flap moves back a few centimetres.

Ways to stop the lid movement

- ▶ By pressing the button **B** » Fig. 58.
- ▶ By pressing the button **C**.
- ▶ By holding the button **D** on the key.
- ▶ By pressing the handle **A**.

Audible signals

When opening the door using the button **C** and opening / closing of the flap using the button **D** audible signals are emitted.

Note

- Button **A** » Fig. 58 is deactivated when starting or at a speed of more than 5 km/h. The button is activated again after the vehicle has stopped and a door is opened.
- If you rapidly enter the vehicle during the opening or closing process of the lid, the whole vehicle may jerk and, as a result, the movement of the lid can be interrupted.

Set the top position of the lid

Read and observe **!** and **!** on page 64 first.

The top position of the lid can be adjusted (e.g. in a limited space to open the lid due to the garage height or for a more comfortable operation, depending on the height of the person).

Adjusting the top position of the lid

- › Stop the lid in the desired position.
- › Press and hold button **B** » Fig. 58 on page 64 until you hear an acoustic signal.

Adjusting the top starting position of the lid

- › Carefully raise the flap manually to the limit.
- › Press and hold button **B** » Fig. 58 on page 64 until you hear an acoustic signal.

Note

The top position which is reached when the lid opens automatically, is always lower than the maximum top position which can be reached when the lid is opened manually.

Malfunctions

Read and observe **!** and **!** on page 64 first.

Examples of operational malfunctions

Description of the malfunction	Remedy
The lid cannot be opened	Unlocking the lid » page 294
The lid does not react to an opening signal	Removing a possible obstacle (e.g. snow), re-opening the lid » page 64 Press handle A » Fig. 58 on page 64 and pull the lid upwards
The lid remains in the top position	Manual closing of the lid
The lid is open and the battery was disconnected	

Close manually

Close the door slowly, push down the lid, push in the lock on the centre of the edge, above the ŠKODA logo.

Operating contactless boot lid

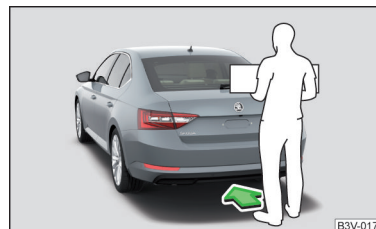

Fig. 59
Opening the boot lid

Read and observe **!** and **!** on page 64 first.

Depending on equipment the boot lid can be operated without contact.



The ignition must be switched off and you have to have the vehicle key on your person.

► To **open/close**, move one foot in the sensor area below the rear bumper quickly in the direction of the arrow » Fig. 59.

The flap opens / closes automatically. When opening the fully closed flap, the brake light in the rear window lights up. An acoustic signal is sounded when closing the lid.

If the lid does not move, then repeat the operating process after a few seconds.

The lid movement can be stopped by a rapid swinging of the foot. Swinging the foot again will continue the lid movement.

The function can be deactivated/activated in Infotainment in the menu  →  → **Opening and closing** → "Easy Open".

We recommend that the function is deactivated in the following cases:

- Installation of a roof rack.
- Connecting a trailer (accessory) to the towbar.
- Manual vehicle wash.
- Maintenance and repair work in the back of the vehicle.

When connecting a device to the trailer socket the deactivation of the function takes place.

Note

With heavy rain or a dirty rear bumper, under certain circumstances that there may be limitations, or the automatic deactivation of the contactless opening function of the boot lid may occur.

Window operation

Introduction

WARNING

- Always close the window carefully and controlled. Doing so may cause yourself or fellow passengers considerable crushing injuries.
- The system is fitted with a force limiter » page 67. If there is an obstacle (e.g. In the event of a body part becoming trapped) the closing process is stopped and the window goes down by several centimetres. However, the windows should be closed carefully – risk of injury.

CAUTION

- Keep the windows clean to ensure the correct functionality of the electric power windows.
- Always close the windows before disconnecting the battery.

Note

If the windows are opened, dust and other dirt can get into the vehicle and the wind noise is more at certain speeds.

Open / close Window

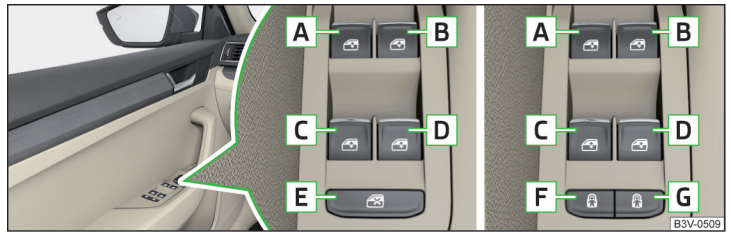

Fig. 60 Buttons for window lifter



Fig. 61 Button of the window lifter on the passenger side

 **Read and observe  and  on page 66 first.**

All windows can be operated from the driver's seat. The window in the front passenger door and the windows in the rear doors are operated via the button in each door. ►



Power window buttons » Fig. 60

- A** Front door left
- B** Front door right
- C** Rear door, left
- D** Rear door, right
- E** Deactivate/activate the buttons in the rear doors (the deactivation may be advantageous if, for example, children are transported on the rear seats)
- F** Deactivation / activation of the key in the rear door left (part of the child safety lock with electric operation)
- G** Deactivation / activation of the key in the back door right (part of the child safety lock with electric operation)

Open/close window

- To **open**, lightly press the appropriate button down and hold it until the window has moved into the desired position.
- **or:** Press the button to the stop; the window automatically opens fully. Renewed pressing of the button causes the window to stop.
- To **close**, pull gently on the top edge of the corresponding button and hold until the window has moved into the desired position.
- **or:** Pull the button briefly to the stop, the window automatically closes fully. Renewed pulling of the button causes the window to stop immediately.

Disable / enable buttons in the rear doors

- To **deactivate/activate** the buttons in the rear doors, press the **E** button. If the buttons in the rear doors are deactivated, the warning light  illuminates in the **E** button.
- **or:** On vehicles with child safety lock with electric operation, press the respective key **F** or **G**. If the buttons in the rear doors are deactivated, the warning light  illuminates in the respective button **F** or **G**.

i Note

- After switching off the ignition, the windows can still open and close for about 10 minutes.
- After the driver or front passenger door is opened, the operation of the window is only possible with the button **A** » Fig. 60, in which case this is pressed or pulled for approx. 2 seconds.

Force limiter

 Read and observe  and  on page 66 first.

The electrical power windows are fitted with a force limiter.

If there is an obstacle, the closing process is stopped and the window goes down by several centimetres.

If the obstacle prevents the window from being closed during the next 10 seconds, the closing process is interrupted once again and the window goes down by several centimetres.



If you attempt to close the window again within 10 seconds of the window being moved down for the second time, even though the obstacle was not yet been removed, the closing process is only stopped. During this time it is not possible to automatically close the window. The force limiter is still switched on.

The force limiter is only not operational if you attempt to close the window again within the next 10 seconds – **the window will now close with full force!**

If you wait longer than 10 seconds, the force limiter is switched on again.

Window convenience operation

 Read and observe  and  on page 66 first.

The convenience operation for the window offers the option to open/close all the windows at once (or only the window in the driver's door). The convenience operation function can be adjusted individually in Infotainment in the menu  /  →  → **Opening and closing**.

Opening

- Press and hold the  button on the key.
- **or:** Switch off the ignition, open the driver's door and hold the key **A** until it stops in the open position » Fig. 60 on page 66.

Closing

- Press and hold the  button on the key.
- **or:** Switch off the ignition, open the driver's door and hold the key **A** until it stops in the closed position » Fig. 60 on page 66.
- In the KESSY system, hold your finger on the sensor on the outside of the door handle of the front door » Fig. 52 on page 59. ▶

The convenience operation will only function correctly if all the windows automatically open/close properly.

Convenience opening or closing the window using the key in the driver's door locking cylinder is only possible within 45 seconds of locking the vehicle.

The movement of the window is stopped immediately when the respective button is released.

Note

The settings for the window convenience operation are stored (depending on the Infotainment type) in the active user account personalisation » [page 55](#).

Malfunctions

Read and observe **!** and **!** on page 66 first.

Repeatedly opening and closing the window can cause the window mechanism to overheat and become temporarily blocked. You will be able to operate the window again as soon as the operating mechanisms has cooled down.

After disconnecting the vehicle battery, automatic opening / closing the window can be deactivated. In this case the system must be **activated** as follows.

Activate window operation

- › Switch-on the ignition.
- › Pull the top edge of the button and close the window.
- › Release the button.
- › Pull up the respective button and hold for 1 second.

Panoramic tilting / sliding sunroof

Introduction

The panorama sliding/tilting roof (hereinafter referred to as sliding/tilting roof) can only be operated when the ignition is turned on and when the outdoor temperature is no lower than -20 °C.

The sliding/tilting roof can still be operated for approx. 10 minutes after switching the ignition off. After opening the driver or front passenger door, it is no longer possible to operate the sliding/tilting roof.

WARNING

When operating the sliding/tilting roof and the sunshade, proceed with caution to avoid causing crushing injuries – risk of injury!

CAUTION

- During the winter, remove any ice and snow in the vicinity of the sliding/tilting roof before opening it to prevent any damage to the opening mechanism.
- Always close the sliding/tilting roof before disconnecting the battery.

Operation

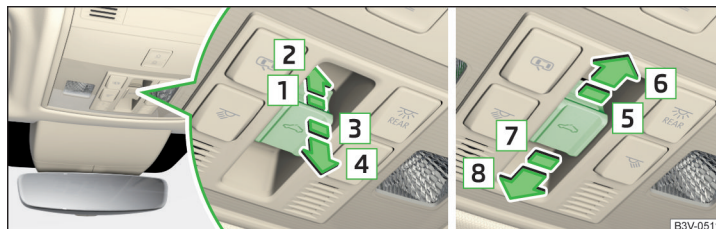

Fig. 62 Operation of the sliding/tilting roof

Read and observe **!** and **!** on page 68 first.

Operation of the sliding/tilting roof » Fig. 62

- 1 Gradual opening
- 2 Complete opening
- 3 Gradually reset
- 4 Fully reset
- 5 Gradual opening
- 6 Fully opening
After the first press, the sliding/tilting roof stops in the position where the intensity of the wind noise is low (at speeds of approx. less than 80 km/h). Press again and the sliding/tilting roof goes to the stop.
- 7 Gradual closing
- 8 Complete closing

Force limiter

Read and observe **!** and **!** on page 68 first.

The sliding/tilting roof is fitted with a force limiter.

If there is an obstacle, the closing process is stopped and the glass pane retracts by several centimetres.



! WARNING

If the sliding/tilting roof is closed by holding down the switch **7** / **8**, » Fig. 62 on page 68 and the closing process is hindered by an obstacle, then when attempting to close for a third time, the force limiter is rendered inoperable (if the period of 5 s is not reached between the individual attempts to close). The sliding/tilting roof closes with full force - it may cause injury.

Convenience operation of the sliding / tilting roof

Read and observe **!** and **!** on page 68 first.

The convenience operation makes it possible to open or close the sliding/tilting roof using the key or the KESSY system via the sensor in the door handle of the front door.

- ▶ To **open out**, press and hold the  button on the key.
- ▶ To **close**, press and hold the  button (with KESSY, hold your finger on the sensor on the outside of the door handle of the front door).

By interrupting the locking process, the closing operation is interrupted.

Activate operation of the sliding/tilting roof



Fig. 63
Operation of the sliding/tilting roof

Read and observe **!** and **!** on page 68 first.

If the operation of the sliding/tilting roof is deactivated (e.g. after disconnecting and connecting the battery), then operation will have to be activated.

- ▶ Switch on the ignition, pull the switch on the recess all the way down in the direction of arrow **1** » Fig. 63 and hold.

The sliding/tilting roof opens/closes again after around 10 seconds.

- ▶ Release the lever.

Manually operated sunshade

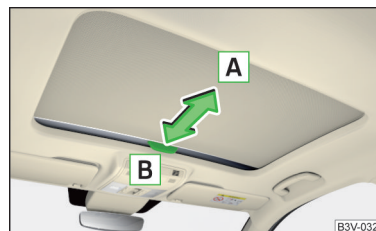

Fig. 64
Operation of the sunshade

Read and observe **!** and **!** on page 68 first.

- ▶ To **open**, pull the handle in the direction of arrow **A** » Fig. 64.
- ▶ To **close**, pull the handle in direction of arrow **B**.

Electrically operated sunshade



Fig. 65
Buttons for operating the sunshade

Read and observe **!** and **!** on page 68 first.

Operation of the sunblind » Fig. 65

- Open - by pressing (press again - sunshade stops moving)
- Close - by pressing (press again - sunshade stops moving)

The sunshade can also be operated by pressing and holding the appropriate button (starts movement of the sunshade) and releasing it when the sunshade reaches the desired position.

Activating operation of the sunshade

Read and observe **!** and **!** on page 68 first.

If the operation of sunshade is deactivated (e.g. after disconnecting and connecting the battery), then the operation will have to be activated.

» Switch on the ignition, press and hold the  » Fig. 65 on page 70 button.

The sunshade opens and closes again after around 10 seconds.

» Release the button.

Lights and visibility

Light

Introduction

Unless otherwise stated, the lights only work when the ignition is switched on. For the basic position of the light switch, use position **AUTO**.

i Note

The headlights may mist up temporarily. When the light is switched on, the light-emitting surface demists after a short period of time.

Operating the lights



Fig. 66
Light switch

To **switch on/off** the lights, turn the **A** » Fig. 66 switch to one of the following positions (equipment-dependent).

0 Switching off lights (except daytime running lights)

AUTO Switching the light on/off automatically » page 72

 Switching on the parking lights or parking lights on both sides » page 74

 Switching on the low beam

Headlight range control of the Halogen headlights

The headlight range can be set in Infotainment in the menu    → Light.

The range of the halogen headlights can be set on the screen, in accordance with the vehicle load, to the following basic settings.

0 Front seats occupied, boot empty

2 All seats occupied, boot empty

- 4 All seats occupied, boot loaded
- 6 Driver seat occupied, boot loaded

In the event of another vehicle loading condition, the setting for positions 1, 3, 5 can be used.

The **Xenon headlights** feature no manual headlight range control. After switching on the ignition, adjust these **automatically** to the load and driving condition of the vehicle.

! WARNING

Always adjust the headlight range control to comply with the following conditions and prevent accidents.

- The vehicle does not dazzle other road users, especially oncoming vehicles.
- The beam range is sufficient for safe driving.

i Note

- If, with a dipped beam, the ignition is turned off, then the dipped beam will automatically switch off and the parking lights will come on. Does not apply to the position **AUTO**, as long as the conditions are met for the COMING HOME function. The parking lights are switched off when the ignition key is removed (for vehicles with the KESSY system, after opening the driver's door).
- If there is a fault in the light switch, the low beam comes on automatically.

Daytime running lights

The daytime running lights illuminate the area in front of and to the rear of the vehicle (only applicable for some countries).

The lights are switched on automatically if the following conditions are met.

- ✓ The light switch is in the position 0 or **AUTO**.
- ✓ The ignition is switched on.

! WARNING

Always switch on the low beam when visibility is poor.

i Note

The light can operate automatically under certain circumstances, even if the light switch is in position 0 or 6.

Turn signal and main beam

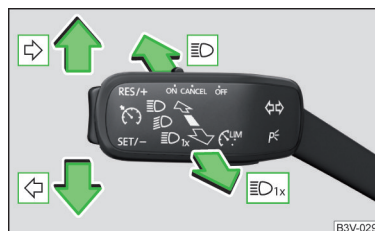

Fig. 67
Operating lever: Turn signal and main beam operation

Control stalk positions » Fig. 67

- ⇨ Switch on the right turn signal
- ⇨ Switch on the left turn signal
- ⇨ Switch on main beam (spring-tensioned position)
- ⇨ Switch off main beam / headlight flasher on (spring-tensioned position)

The **main beam** can only be switched on when the low beam lights are on.

The **headlight flasher** can be used even if the ignition is switched off.

The **turn signal** switches off automatically depending on the steering angle after turning.

Use the control stalk to switch on/off the **headlight assistant**» page 74.

Comfort indicating

When the control stalk is pressed slightly up or down, the respective turn signal indicates three times.

If during the convenience turn signal, the operating lever is pressed in the opposite direction, the indicating will stop.

Convenience signalling can be activated/deactivated in Infotainment in the menu **CAR** → **Light** /

! WARNING

Only turn on the main beam or the headlight flasher if other road users will not be dazzled.

i Note

The setting (activation/deactivation) of the convenience turn signal is stored (depending on the Infotainment type) in the active user account personalisation » [page 55](#).

Automatic driving light control



Fig. 68
Light switch: Position AUTO

If the light switch is in position **AUTO** » [Fig. 68](#), then the lights are automatically switched on/off to suit current light or weather conditions (rain), depending on the equipment.

If the light switch is in position **AUTO**, the lettering **AUTO** illuminates next to the light switch. If the light is switched on automatically, the symbol  also illuminates next to the light switch.





Automatic driving light control in the rain (referred to as function in the following)

The dipped beam is switched on automatically if the following conditions are met.

- ✓ The function is activated.
- ✓ The light switch is in the position **AUTO**.
- ✓ The windscreen wipers are on for more than 30 s.

The light turns off automatically about 4 minutes after turning off the wipers.

Setting, activation/deactivation

The following functions can be set or activated/deactivated in Infotainment in the menu **CAR**     **Light**.

- ▶ Sensitivity adjustment of the sensor for determining the lighting conditions for automatic driving light control
- ▶ Automatic driving light control during rain

! WARNING

The automatic driving lamp control (position **AUTO**) only operates as a support and does not release the driver from his responsibility to check the lights and, if necessary, to switch on the light depending on the prevailing light conditions.

! CAUTION

Poorer visibility is evaluated by a sensor mounted below the windscreen in the holder of the rear-view mirror. Do not cover the sensor - the system can be affected.

i Note

The setting (activate/deactivate) of the automatic driving light control during rain is stored (depending on the Infotainment type) in the active user account personalisation » [page 55](#).

Xenon headlight

The Xenon headlights (hereinafter referred to as just system) use the driving data to automatically ensure the for the best possible light cone in front of the vehicle.

The system operates automatically in the following modes: urban, extra-urban, highway, rain, fog, adjusting the lighting direction of the headlights for the road illumination in curves.

The system works as long as the light switch is in position **AUTO**.

! WARNING

If there is a system malfunction the headlights are automatically lowered to the emergency position, which prevents a possible dazzling of oncoming traffic. This reduces the cone of light in front of the vehicle. Seek help from a specialist garage.

Fog lights/rear fog light



Fig. 69
Light switch – switch on front and rear fog lights

Switching on the fog lights/rear fog lights is possible under the following conditions.

- ✓ The lights switch is in position **AUTO**, or » Fig. 69.
- To **switch on the fog lights**, turn the light switch to position **1**; the warning light illuminates in the instrument cluster.
- To **switch on the rear fog lights**, pull the light switch to position **2**; the warning light illuminates in the instrument cluster.

If the vehicle is not equipped with **fog lights**, the **rear fog lights** can be switched on by pulling the light switch to the only possible setting.

Switch off the fog lights/rear fog lights in reverse order.

i Note

If an accessory is connected to the trailer socket, the rear fog lamp does not light up on the vehicle.

function CORNER

The CORNER function automatically switches on the fog lights on the respective side of the vehicle (e.g. when cornering or steering), if the following conditions are fulfilled.

- ✓ The turn signal is turned on or the front wheels are severely locked (in the event of conflict between the two versions, has turn signal has the higher priority).
- ✓ The vehicle speed is below 40 km/h.
- ✓ The low beam is switched on.
- ✓ The fog lights are not switched on.

The two fog lights are switched on when you shift into the reverse gear.

COMING HOME / LEAVING HOME

The function **COMING HOME** ensures that the vehicle's environment is illuminated after switching off the ignition and opening the driver's door.

The function **LEAVING HOME** ensures that the vehicle's environment is illuminated after unlocking the vehicle with the radio remote control unit.

The function switches the light on only if there is poorer visibility and the light switch is in the position **AUTO**.

The two functions can be used in Infotainment in the menu → → **Light (activated/deactivated and adjusted)**.

! CAUTION

- Poorer visibility is evaluated by a sensor mounted below the windscreen in the holder of the rear-view mirror. Do not cover the sensor - the system can be affected.
- If this option is always enabled, then the battery is heavily loaded.

i Note

The setting of the two functions is stored (depending on the Infotainment type) in the active user account personalisation » page 55.

Hazard warning light system



Fig. 70
Button for hazard warning light system

➤ To **switch on/off**, press the button » Fig. 70.

When switching on, all the turn signal lights as well as the warning light in the button flash simultaneously with the control lights in the instrument cluster.

The hazard warning light system can also be operated if the ignition is switched off.

If one of the airbags is deployed, the hazard warning light system will switch on automatically.

The automatic activation of hazard warning lights can take place during a heavy braking. After starting or accelerating the hazard warning system is automatically switched off.

When the hazard warning system is on and the turn signal is switched on, the hazard warning lights are switched off temporarily and only the turn signal flashes on the relevant side of the vehicle.

Parking light

The side light is provided for lighting of the parked vehicle.

Switching on the side light $P \leq$ on one side

- › Switch off the ignition.
- › Press the control lever all the way into position \rightarrow or \leftarrow until it stops » Fig. 67 on page 71.

The parking lights on the respective side of the vehicle are turned on.

Switching on the side light on both sides $\Rightarrow \Leftarrow$

- › Turn the ignition on and turn the light switch to position $\Rightarrow \Leftarrow$ » page 70.
- › Switch off the ignition and lock the car.

After removing the ignition key and opening the driver's door, an audible warning sounds. After a few seconds, or after closing the driver's door, the acoustic warning signal stops.

! CAUTION

- Turning on the parking light means the battery is heavily loaded.
 - The parking lights may switch off automatically due to a low battery charge.
- If the two-sided parking lights are switched on when the ignition is off, the parking lights will not switch on automatically.

Entry space lighting

The lighting is positioned on the lower edge of the exterior mirror and illuminates the entry area of the front door.

The lighting **switches on** after unlocking or opening the vehicle door (depending on the lighting conditions).

The lighting **switches off** after around 30 seconds after closing the front door or switching on the ignition.

Driving abroad

When driving in countries with opposing traffic system (traffic on the left/right), headlights may dazzle oncoming traffic.

Therefore, the Xenon headlight setting must be adapted by turning on **travel mode** in infotainment in the menu **CAR** / \rightarrow \rightarrow \rightarrow **Light** menu. In this mode, no automatic beam adjustment is made ahead of the vehicle.

Headlight Assist (Light Assist / Dynamic Light Assist)

Introduction



Fig. 71
Sensor window for the headlight assistant

The headlight assistant (referred to as just system in the following) automatically switches the main beam on/off, if necessary, adjusts the beam of the front headlights in accordance with the existing traffic situation (other vehicles) and environmental conditions (e.g. driving through a lit village).

The switching on/off of the main beam, if necessary, the adaptation of the headlight, is controlled by a sensor » Fig. 71.

Depending on the equipment, the following system versions can exist.

Light Assist automatically switches the main beam on/off.

Dynamic Light Assist automatically adjusts the light cone shape of the front headlights in order to prevent dazzling the oncoming and preceding vehicles, while ensuring the highest possible illumination of the road edges.

If the driving mode **Eco** » page 244, *Select the driving mode (Driving Mode Selection)* or **travel mode** » page 74, *Driving abroad* is selected, the automatic adjustment of the beam is deactivated, **Dynamic Light Assist** only switches the main beam on/off automatically.

If the Xenon headlights are in the mode **rain** or **fog** » page 72, then **Dynamic Light Assist** is deactivated.

If there is a **fault**, the error message will appear in the instrument cluster display. Seek help from a specialist garage.

! WARNING

The system is used only for support, thus the driver is not released from his obligation to manually adjust the main or low beam according to the given ambient conditions (e.g. in unfavourable lighting and weather conditions, as when passing poorly lit road users, if necessary, when the area in front of the sensor is covered by an obstacle).

! CAUTION

Do not attach any stickers or similar objects in front of the sensor on the windscreen to avoid impairing the function of the system.



i Note

The adjustment of the headlight assistant in Infotainment is stored (depending on the Infotainment type) in the active user account personalisation » page 55.

Operating conditions

📖 Read and observe ! and ! on page 75 first.

The system works under the following conditions.

- ✓ The system is activated in Infotainment in the menu   →  → **light** activated.
- ✓ The light switch is in the position **AUTO**.
- ✓ The system is activated » page 75, *System on/off*.
- ✓ The vehicle speed is over 60 km/h or for some countries more than 40 km/h.
- ✓ The windscreen is clean in the sensor area.

System on/off

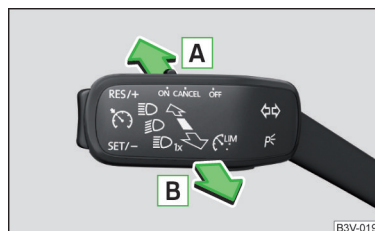





Fig. 72
Operating lever: Headlamp assistant

📖 Read and observe ! and ! on page 75 first.

Switch on the system

- Push the lever into the sprung position **A** » Fig. 72. The following indicator light  lights up in the instrument cluster display.

Switch off the system

- If the high beam is switched on automatically, move the lever into the sprung position **B**. The warning light  goes out. The high beam turns off.
- If the high beam is **not** switched on automatically, move the lever into the sprung position **A**. The warning light  goes out. The high beam turns on.

The high beam switches off automatically when the speed falls below 30 km/h (but the system remains switched on).

Interior lighting

📖 Introduction

The inner lighting also works if the ignition is switched off. With the ignition off (or after a door is opened), the lights will automatically switch off after approximately 10 minutes.

Operation of the lights from the front seats

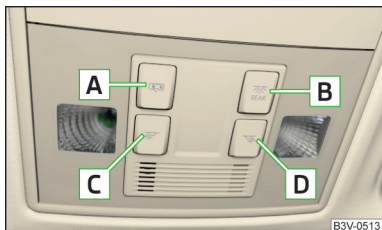

Fig. 73
Operation of the lights from the front seats

Switch on/off (by pressing the relevant switch) » Fig. 73

- A** Automatic operation
- B** REAR Rear lighting
- C** Depending on equipment fitted:
 - ▶ Reading light left
 - ▶ Front and rear lighting
- D** Reading light right

Automatic operation - switch

The system is **turned on** when any of the following is present.

- ▶ The vehicle is unlocked.
- ▶ One of the doors is opened.
- ▶ The ignition key is removed.

The system is **turned off** when any of the following is present.

- ▶ The vehicle is locked.
- ▶ The ignition is switched on.
- ▶ About 30 seconds after all the doors have been closed.

Interior light, rear

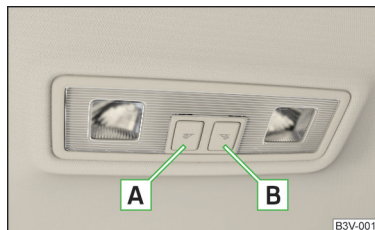

Fig. 74
Interior lights at the rear: Variant 1

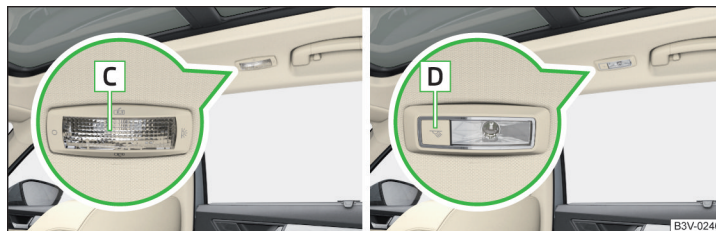

Fig. 75 Interior lights at the rear: Version 2/version 3

The rear lighting (variants 1 and 3) is controlled together with the automatic operation of the lighting from the front seats.

Variant 1 - switch on/off (by pressing the relevant switch) » Fig. 74

- A** Reading light left
- B** Reading light right

Variant 2 - operation (by moving the light lens C) » Fig. 75

- Switching on
- 0** Switching off
- Automatic operation (the light is switched on/off automatically together with the front light)

Variant 3 - switch on/off (by pressing the relevant switch) » Fig. 75

- D** Reading light left
- Reading light right

Ambient lighting

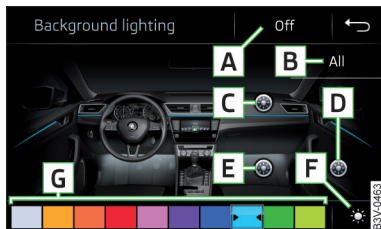





Fig. 76
Setting the ambient lighting

The ambient lighting illuminates the dashboard and side door trim panels in colour, and the footwell in white.

The **switching on** of the lighting takes place automatically after opening the door, **switching off** occurs automatically after the locking of the vehicle or 30 seconds after the closing of the door with the ignition switched off.

The ambient lighting can be adjusted in Infotainment in the menu  /  →  → **Background lighting**.

Description of the function surfaces » Fig. 76

- A** Enable / disable the background lighting
- B** Activating of the brightness setting for all areas at the same time
- C** Activating of the brightness setting for the dashboard area
- D** Activating the brightness controls for the door area
- E** Activating the brightness setting for the footwell area
- F** Choice of colour options / brightness adjustment
- G** Function surfaces for selecting lighting colour / brightness adjustment

To display **B**, **C**, **D** and **E** tap on the function surface *.

Vehicles by selecting the driving mode

For vehicles with driving mode selection » page 244 The lighting can be switched on automatically or manually **A** » Fig. 76. A change in the illumination colour occurs automatically due to the driving mode change or manually by selecting one of the colour options. In individual mode, the last manually selected colour is displayed.

Note

The adjustment of the ambient lighting is stored (depending on Infotainment type) in the active user account personalisation » page 55.

Visibility

Introduction

! WARNING

No objects should be attached to the sun visors, which could limit the view or endanger the vehicle occupants during sudden braking or should the vehicle collide.

Windscreen and rear window heater





Fig. 77 Buttons for the front and rear window heater: Climatronic / manual air conditioning

 **Read and observe !** on page 77 first.

The heating for quick defrosting and ventilation of the front /and rear window. The heating only works when the engine is running.

Buttons for the heating (depending on vehicle equipment) » Fig. 77

-  Switching the windscreen heater on/off
-  Switch on/off the rear window heater

When the heating is switched on, a light illuminates inside or below the button.

The heating automatically switches off after ten minutes. ▶

If the engine is switched off when the heating is on and turned back on again within 10 minutes, the heating is continued.

I Note

- If the on-board voltage decreases, the heating switches off automatically » [page 274](#), *Automatic consumer shutdown - discharge protection of the vehicle battery*.
- If the lighting inside or below the button flashes, the heater will not work because of the low charge of the battery.
- If the Climatronic recognises that the windshield could fog up, the windshield heating is automatically switched on. This function can be activated/deactivated on the Climatronic control panel in the menu **MENU** →

Front sun visors

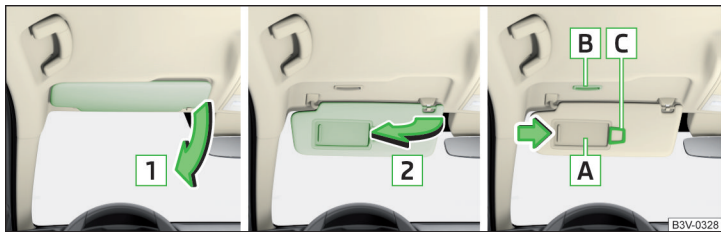

Fig. 78 Fold down flap / flip up flap / make-up mirror and parking permit holder

Read and observe ! on page 77 first.

Operation and description of the sun visor » [Fig. 78](#)

- 1** Swivel the visor towards the windscreen
 - 2** Swivel cover towards the door
- A** Make-up mirror with cover (the cover can be pushed in the direction of the arrow)
 - B** Light (turns on when the cover of the make-up mirror is pushed to one side)
 - C** Parking ticket holder

Sunshade

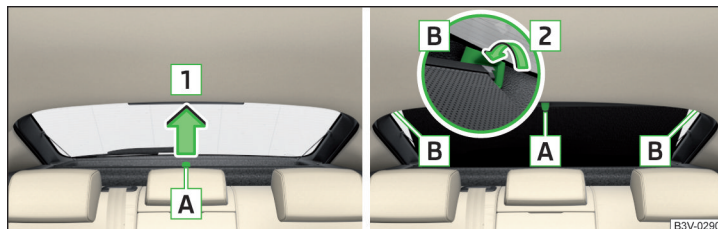

Fig. 79 Sun screen

Read and observe ! on page 77 first.

The sun screen is located in a housing on the luggage compartment cover.

- To **roll down**, pull the sunshade by the handle **A** in direction of arrow **1** and suspend in the magnetic holder **B** in the direction of arrow **2** » [Fig. 79](#).
- To **roll up**, pull the sunshade by the handle **A** out of the holder **B** against the direction of arrow **2**. Hold the sunshade so that this can slowly roll back in without damaging.

Sunshade in the rear doors



Fig. 80 Sun blind on the rear door

📖 **Read and observe** **!** on page 77 first.

- To **roll down**, pull out the sunshade by the handle **A** in direction of arrow **1** and suspend in the holder **B** on top edge of the door in the direction of arrow **2** » Fig. 80.
- To **roll up**, hold the sunshade by the handle **A** and remove it from the holder **B** against the direction of arrow **2**. Hold the sunshade so that this can slowly roll back in without damaging.

Windscreen wipers and washers

📖 Introduction

The windscreen wipers and the wash system operate if the ignition is switched on and the bonnet and boot are closed.

! WARNING

Do not use the windscreen washer system at low temperatures, without heating the windscreen beforehand. The window washer fluid could otherwise freeze on the windscreen and restrict the view to the front.

! CAUTION

- If the windscreen wipers are in rest position, they cannot be folded out from the windscreen. The wipers must be set to the service position to raise them off the windscreen » page 294.
- In cold temperatures and during the winter, check before switching on the ignition that the wiper blades are not frozen to the windscreen. If the windscreen wipers are switched on when the blades are frozen to the windscreen, this may damage both the blades and windscreen wiper motor.
- Carefully release the frozen-on windscreen wiper blades from the windscreen and remove snow and ice.
- Handle the windscreen wipers with care - there is the risk of damaging the windscreen with the windscreen wiper arms.
- Do not switch on the ignition when the front windscreen wiper arms are folded down - there is the danger of damaging the bonnet by the windscreen wiper arms.
- If there is an obstacle on the windscreen, the wipers will try to push away the obstacle five times. Thereafter, the wipers will stop to prevent them becoming damaged. Turn on the wipers again only after the obstacle has been removed.

i Note

- Each time the ignition switches off for the third time, the position of the windscreen wipers changes. This counteracts an early fatigue of the wiper blades.
- The windscreen washer nozzles for the windscreen are heated when the engine is running and the outside temperature is less than +10 °C.

Front wipers and washers



Fig. 81
Operating the windscreen wipers and washing system at the front

Read and observe **!** and **!** on page 79 first.

HIGH Fast disk wiping

LOW Slow disk wiping

INT Depending on equipment fitted:

- ▶ Intermittent wipe of the windscreen
- ▶ Automatic windscreen wiping in the rain

OFF Wipers and washers off

1x Single windscreen wipe (sprung position)

A ... Setting of windscreen wiper interval for the position **INT** - by setting the switch in the direction of the arrow, the windscreen wipers will wipe more often

Spraying and wiping the windscreen (sprung position)

Spraying and wiping the windscreen

After releasing the operating lever, the wipers will make from 2 to 3 wiper strokes.

At a speed of more than 2 km/h, the wiper wipes once again 5 seconds after the last wiper stroke in order to wipe the last drops from the windscreen. This function can be activated/deactivated by a specialist garage.

Automatic windscreen wiping in the rain can be used in Infotainment in the menu → **Mirrors and wipers (activated/deactivated)**.

! WARNING

Automatic wiping during rain is only a support. The driver is not released from the responsibility to set the function of the windscreen wipers manually depending on the visibility conditions.

i Note

- If the wiping is carried out without interruption, the wiping speed varies depending on the vehicle speed.
- The setting (activation/deactivation) of the automatic windscreen wiping in the rain is stored (depending on the Infotainment type) in the active user account personalisation » [page 55](#).

Rear window wipers and washers



Fig. 82
Operating the windscreen wipers and washing system

Read and observe **!** and **!** on page 79 first.

Spraying and wiping the windscreen (sprung position) - after releasing the control stalk, the wipers perform another 2 to 3 wiper strokes

Windscreen wiping

OFF Wipers and washers off

Automatic rear wiper

If the windscreen wiping is performed without interruption, then the automatic regular intermittent wiping of the rear window takes place.

This function can be activated/deactivated in Infotainment in the menu → → **Mirrors and wipers (activated/deactivated)**.

i Note

- The rear window is wiped automatically if the windscreen wipers are on when reverse gear is selected.
- The setting (activation/deactivation) of the automatic rear window wiping in the rain is stored (depending on the Infotainment type) in the active user account personalisation » [page 55](#).

Headlight cleaning system

📖 Read and observe **!** and **!** on page 79 first.

Headlights are cleaned under the following conditions.

- ✓ The low beam is switched on.
- ✓ The outside temperature is about -12° C to +39° C.

To clean the headlights, the headlamp is also sprayed after spraying the windscreen every first and tenth time. Setting the spray interval can be carried out by a specialist garage.

To ensure the correct functioning of the system, even in winter, this needs to be regularly cleared of snow and ice (e.g. using the de-icing spray).

Rear view mirror

📖 Introduction

! WARNING

Exterior mirrors increase the field of view, however, make objects appear smaller and further away. Therefore, use the rear-view mirror to determine the distances to the following vehicles.

! WARNING

- The mirrors with automatic dimming contain electrolyte fluid which may leak if the mirror glass is broken - this can irritate skin, eyes and the respiratory system.
- If your eyes or skin come into contact with the electrolyte fluid, immediately wash the affected area for a few minutes with plenty of water. Seek medical assistance if required.

Interior mirror dimming

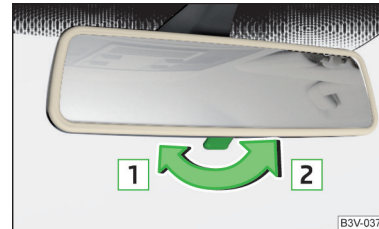

Fig. 83
Rear-view mirrors with manual dimming

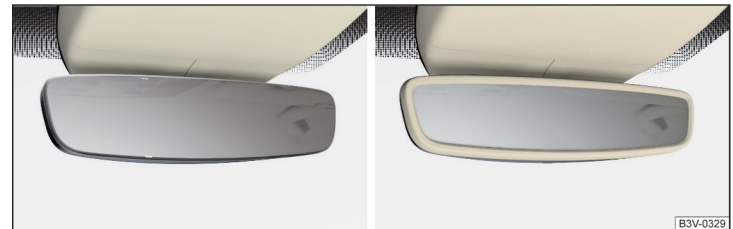

Fig. 84 Rear-view mirrors with automatic dimming: Version 1/version 2

📖 Read and observe **!** on page 81 first.

Mirrors with manual dimming » Fig. 83

- 1 Basic position of the mirror (not dimmed)
- 2 Mirror blackout

Mirror with automatic dimming

The mirror dimming » Fig. 84 is automatically controlled after the engine start.

When the interior lights are switched on or the reverse gear is engaged, the mirror moves back into the basic position (not dimmed). ▶

! WARNING

- Attach external devices (e.g. navigation system) not in the vicinity of the **mirror with automatic dimming**. The illuminated display of an external device can affect the function of the rear-view mirror - it could cause an accident.
- The automatic dimming mirror only functions smoothly if the light falling on the sensors is not compromised (e.g. by the sunshade at the back). The sensors are located on the front and back of the mirror.

Exterior mirrors

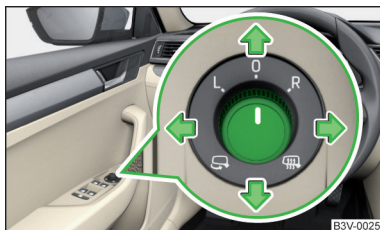

Fig. 85
Exterior mirror operation

📖 Read and observe ! on page 81 first.

The exterior mirrors can (depending on vehicle equipment) have a manual or electric fold-in function, automatic dimming and memory function.

The rotary knob can be moved into the following positions (depending on vehicle equipment)

- L Adjusting the left-hand mirror area
- 0 Switch off mirror control
- R Adjusting the right-hand mirror area
- 🔥 Mirror heating (only works when the engine is running)
- 🔄 Folding in the mirrors electrically (to fold back, move the rotary knob to another position) » !

Setting the mirror area

➤ Move the rotary knob in the direction of arrows » Fig. 85.

If the mirror setting fails at any time, the mirrors can be adjusted manually by pressing on the edge of the mirror area.

Setting the mirror surfaces synchronously

This function allows the simultaneous adjustment of the two mirror areas. The function can be activated/deactivated in Infotainment in the menu → → → **Mirrors and wipers** (activated/deactivated).

- Turn the knob for the mirror control to the position for the driver mirror adjustment.
- Adjust the mirror areas to the desired position.

Manual folding mirrors

The mirror can be manually folded towards the side windows. To put it back to its original position, it should be folded back from the side window until it audibly clicks into place.

Automatic folding in/back of both mirrors

The exterior mirrors are automatically collapsed after locking the vehicle in the park position. After unlocking the vehicle, the mirrors are folded back to the driving position » !.

This function can be activated/deactivated in Infotainment in the menu → → → **Mirrors and wipers** (activated/deactivated).

Mirror with automatic dimming

The exterior mirror dimming is controlled together with the automatic rear-view mirror dimming » page 81.

Memory function for mirror (vehicles with electrically adjustable driver's seat)

It is possible to save the current setting of the exterior mirror when saving the driver's seat position with » page 85, *Memory Function of the electrically adjustable seat* or » page 85, *Memory function of the remote control key*.

Tilting the mirror area of the front passenger mirror (vehicles with electrically adjustable driver's seat)

The front passenger mirror area can be tilted to the stored position to improve the view to the curb when reversing.

Operating conditions

- ✓ The function can be activated in Infotainment in the menu → → → **Mirrors and wipers**.
- ✓ The setting of the mirror area has been previously stored » page 85, *Memory Function of the electrically adjustable seat* or. » page 85, *Memory function of the remote control key*.

- ✓ The reverse gear is engaged.
- ✓ The knob for the mirror control is in the position for the passenger mirror adjustment.

The mirror area returns to its initial position after the rotary knob is set to another position or if the speed is greater than 15 km/h.

! WARNING

Do not touch the exterior mirror surfaces, if the exterior mirror heating is switched on - hazard of burning.

! CAUTION

- Never manually fold in/out the electrically folding exterior mirrors - there is a risk of damage to the mirror!
- When the mirror is swung by external influences (due to impact during manoeuvring, for example), then first **fold-in** the mirror by turning the knob and wait for a loud clapping noise.

i Note

The setting of the mirror functions is stored in Infotainment (depending on the Infotainment type) in the active user account personalisation » [page 55](#).

Seats and head restraints

Front seats

📖 Introduction

! WARNING

- Only adjust the driver's seat when the vehicle is stationary – risk of accident!
- Caution when adjusting the seat! You may suffer injuries or bruises as a result of adjusting the seat without paying proper attention.

Manual adjustment

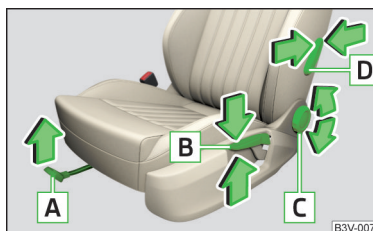

Fig. 86
Control elements on the seat

📖 Read and observe ! on page 83 first.

- A** Adjusting the seat in the longitudinal direction (after releasing the control lever must lock audibly)
- B** Adjusting height of seat
- C** Adjust the tilt of the backrest (do not lean on the backrest when adjusting)
- D** Setting the extent of the curvature of the lumbar support

i Note

After a certain time, play can develop within the adjustment mechanism of the backrest angle.

Electrical adjustment

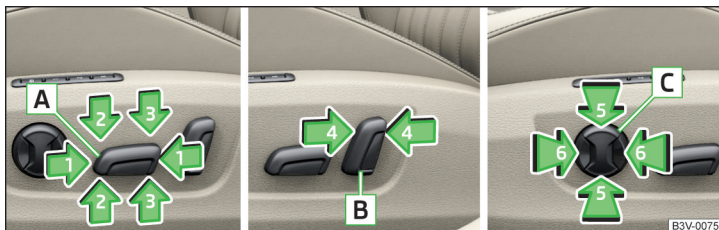

Fig. 87 Control elements on the seat

Read and observe **!** on page 83 first.

- A** seat adjustment
 - ▶ 1 - Move in the longitudinal direction
 - ▶ 2 - Change in inclination
 - ▶ 3 - Change in height
- B** Adjusting the seat backrest
 - ▶ 4 - Change in inclination
- C** Adjusting lumbar support
 - ▶ 5 - Change curvature
 - ▶ 6 - The degree of curvature change

! WARNING

The electric front seat adjustment is functional even with the ignition off. Therefore, when leaving the vehicle, never leave people who are not completely independent, such as children, unattended in the vehicle - there is a danger of injury!

i Note

- If the inclination angle of the seat backrest relative to the seat surface is greater than approx. 110°, then it is not possible for safety reasons to save this setting in the memory of the electrically adjustable seats or the remote control key.
- On vehicles with personalisation, the driver's seat setting is stored in the active user account personalisation » page 55.

Driver's seat with massage function



Fig. 88 Button for the massage function

Read and observe **!** on page 83 first.

The massage function is used to massage the lumbar area of the back.

▶ To switch on/off, press the  button » Fig. 88.

! WARNING

Only switch the massage function on and off when the vehicle is stationary - otherwise there is risk of an accident.

i Note

The massage function switches off automatically after approximately 10 minutes.

Convenience operation of the front passenger seat

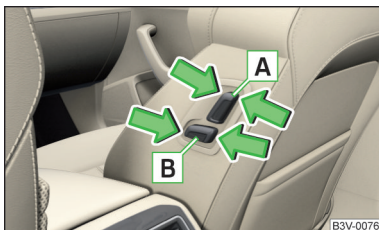

Fig. 89
Operating elements on the front passenger's seat

Read and observe **i** on page 83 first.

The front passenger seat can also be operated from the rear seats, by pressing the respective operating element in the direction of the arrows » Fig. 89.

- A** Adjusting the angle of the seat backrest
- B** Adjusting a seat in a forward/back direction

Memory Function of the electrically adjustable seat

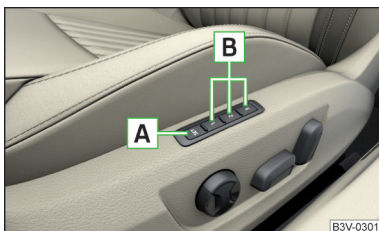

Fig. 90
SET button and memory buttons

Read and observe **i** on page 83 first.

Among the memory buttons **B** on the driver's seat, a setting for the driver's seat and exterior mirror position can be saved » Fig. 90.

Storing seat and exterior mirror settings for driving forward

- › Switch on the ignition, adjust the seat and the exterior mirrors, as required.
- › Press the SET **A** » Fig. 90 button and then, within 10 seconds, press the desired memory button **B**. Storing is confirmed by an acoustic signal.

Storing front passenger's exterior mirror settings for reversing

The function for lowering the front passenger's mirror area during reversing can be activated in Infotainment in the menu **CAR/** → **Mirrors and wipers**.

- › Turn on the ignition and press the desired memory button **B** » Fig. 90.
- › Turn the rotary knob for the exterior mirror control to the position for the front passenger mirror area » page 82.
- › Engage reverse gear.
- › Adjust the front passenger's mirror to the desired position.
- › Disengage reverse gear. The set position of the exterior mirror is stored.

Retrieving the saved setting

- › With the ignition off and the driver's door open-press- the desired memory button **B**.
- › In other cases (e.g. if the ignition is switched on or the driver's door closed), hold the button.

Stopping the ongoing adjustment

- › Press any button on the seat that is to be set. The driver's seat can also be stopped by pressing the button on the radio-operated key.

i Note

Every time you save new seat and exterior mirror settings for driving forwards, you must also save the front passenger mirror setting for reversing again.

Memory function of the remote control key

Applies to vehicles that do not have the personalisation function.

Read and observe **i** on page 83 first.

Every time the vehicle is locked, the driver's seat and exterior mirror settings are saved and assigned to the key with which the vehicle was locked.

After the following unlocking of the vehicle with the same key and opening the driver's door, the driver's seat and exterior mirrors that are saved to this key will be adopted.

This function can be used in Infotainment in the menu **CAR/** → → **Seats activated/deactivated**.

Storing front passenger's exterior mirror settings for reversing

The function for lowering the front passenger's mirror area during reversing can be activated in Infotainment in the menu **CAR/** → → **Mirrors and wipers**. ▶

- › Unlock the vehicle with the remote control key and switch on the ignition.
- › Turn the rotary knob for the exterior mirror control to the position for the front passenger mirror area » [page 82](#).
- › Engage reverse gear.
- › Adjust the front passenger's mirror to the desired position.
- › Disengage reverse gear. The adjusted position of the exterior mirror is stored in the remote control key memory.

Stopping the ongoing adjustment

- › Press any button on the driver's seat or the  button on the remote control key.

Folding front passenger seat

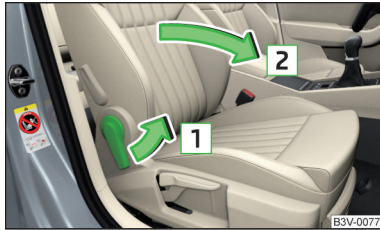





Fig. 91
Folding the front passenger seat forward

 Read and observe  on [page 83](#) first.

The front passenger seat can, (depending on equipment fitted), be folded forward into a horizontal position.

- › To **fold down**, pull the lever in direction of arrow , fold the seat backrest in the direction of arrow  » [Fig. 91](#). The locking mechanism must audibly snap into place.
- › To **fold up**, pull the lever in direction of arrow , fold back the seat backrest against the direction of arrow . The locking mechanism must audibly snap into place.
- › Check this by pulling on the seat and on the backrest.

WARNING

- If the seat backrest is folded down, only the seat behind the driver's seat can be used to transport passengers.
- When transporting objects on the folded seat backrest, the front passenger airbag should be deactivated » [page 28](#).

WARNING (Continued)

- Do not adjust the seat backrest while driving - it can cause injury and accidents!
- When moving the seat backrest, keep limbs out of the area between the seat and seat backrest – risk of injury!
- Never transport the following items on the seat backrest when folded forwards.
 - Objects that could restrict the driver's view.
 - Objects which make it impossible for the driver to control the vehicle, e.g. if they roll under the pedals, or could protrude into the driver's zone.
 - Objects which could lead to injury to passengers due to a change of direction or braking manoeuvre when accelerating sharply.

Armrest setting

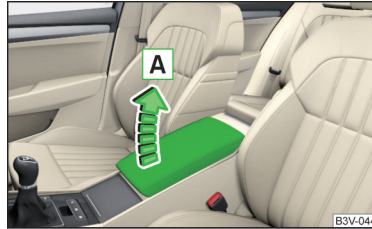



Fig. 92
Adjust armrest

 Read and observe  on [page 83](#) first.

- › To **adjust the height**, lift the armrest in the direction of the arrow  into one of the locking positions » [Fig. 92](#).
- › To **close**, lift the armrest in the direction of arrow  past the stop and then fold down again.

Rear seats

Seat backrests

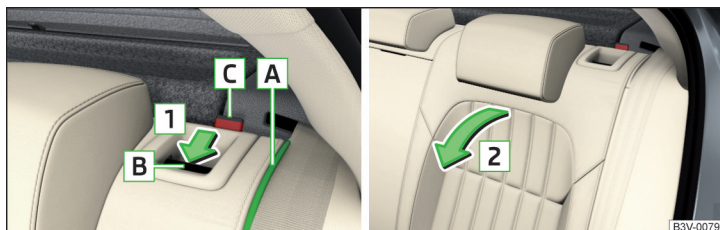

Fig. 93 **Folding down the seat backrests from the forward from the passenger compartment**



Fig. 94
Fold the backrest forward from the luggage compartment

Before folding the seat backrests forwards, adjust the position of the front seats in such a way that they are not damaged by the seat backrests. Remove the rear headrests if required » [page 89](#).

Folding forwards from the passenger compartment

- › Place the outer seat belt behind the raised edge **A** » [Fig. 93](#).
- › Push the release lever **B** in the direction of arrow **1** and fold down the seat backrest in the direction of arrow **2**.

Fold forward from the luggage compartment

On vehicles with a net partition, the left and then the right and middle rear seat backrest must first be unlocked. The net partition must be rolled up in the housing.

- › Pull the corresponding lever in the direction of the arrow » [Fig. 94](#). The respective seat backrest is unlocked or folded forward.

Folding backwards

- › Place the outer seat belt behind the raised edge **A** » [Fig. 93](#).
- › Lift the seat backrest against the direction of arrow **2** until the release lever **B** audibly locks. Check this by pulling on the seat backrest.
- › Make sure that the red pin **C** is hidden.

! WARNING

- The seat backrests in the occupied rear seats must be properly engaged.
- When transporting objects in the luggage compartment that has been enlarged by folding the backrest forward, ensure the safety of the passengers transported on the other rear seats.
- The seat backrests must be securely latched in position so that no objects from the luggage compartment can slip into the passenger compartment under sudden braking – risk of injury.

! CAUTION

When operating the seat backrests, the seat belts must not be pinched - there is a risk of damage to the seat belts.

Fold down armrest



Fig. 95
Fold down armrest

The armrest can be **folded down** in the direction of the arrow » [Fig. 95](#).

The folded-down armrest can be used as a side table.

Headrests

Introduction

Note

In sports seats, the headrests are integrated into the seat backrests and cannot be adjusted in height.

Adjust height of front head restraint

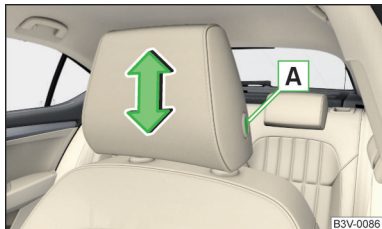

Fig. 96
Setting the height of the front headrest

› To **adjust the height**, hold the locking button **A** and move the rest in the desired direction » Fig. 96.

CAUTION

If the tablet holder adapter is secured to the guide rods of the headrests » page 103, do not push the headrests down to the stop – risk of damaging the headrests.

Adjusting the rear headrests



Fig. 97 Setting the height of the rear headrest

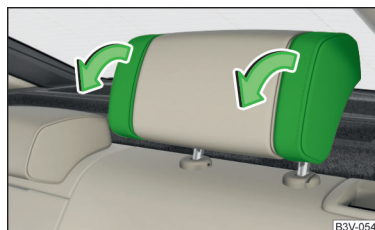

Fig. 98
Fold down side bolsters of the comfortable headrests

Setting the height

- › Grasp the headrest and move **upwards** in the direction of **1** » Fig. 97.
- › To move the restraint **down**, hold the locking button **A** in the direction of arrow **2** and push the rest in the direction of arrow **3**.

Comfortable headrests

The rear headrests can be equipped with side bolsters. These reduce uncontrolled movement of the head sideways (e.g. when sleeping).

- › Adjust the headrest to the initial pulled out position » page 88, *Adjusting the rear headrests*.
- › Fold down the sides of the head restraint in the direction of arrow » Fig. 98.

Removing/inserting the rear headrests

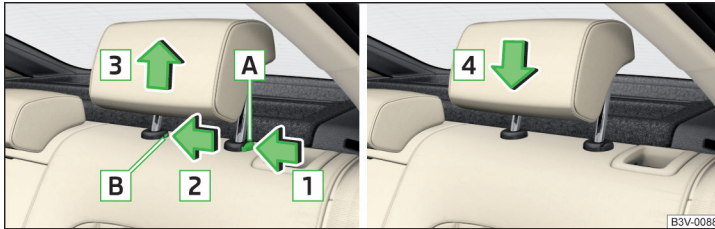

Fig. 99 Removing/inserting the rear headrest

- To **remove**, pull the rest out of the seat backrest up to the stop.
- Hold the locking button **A** in the direction of arrow **1**, at the same time using a flat screwdriver with a max. width of 5 mm to press the locking button in the opening **B** in the direction of arrow **2** and pull out the rest in the direction of arrow **3** » Fig. 99.
- To **insert**, push the rest into the seat backrest in the direction of arrow **4** until the locking button clicks into place.

Seat heating and ventilation

Introduction

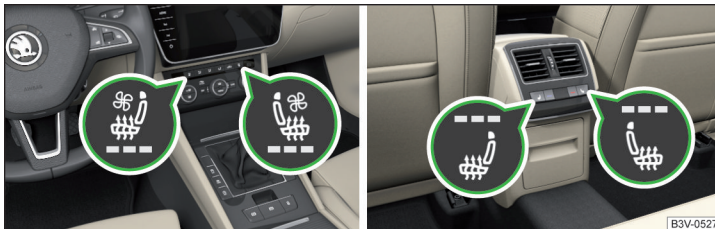

Fig. 100 Button arrangement: Heated front seats (and ventilation) / heated rear seats

Depending on the equipment, the **front seats** can be heated or heated and ventilated. The **outer rear seats** can only be heated.

Buttons for the seat heating and ventilation » Fig. 100

- ☞ Left seat heating
- ☞ Right seat heating
- ☞ Seat heating and ventilation left
- ☞ Seat heating and ventilation right

The seat heating / ventilation only works when the engine is running.

When the ignition is switched off, the seat heating / ventilation is also switched off. If the engine is started again within 10 minutes, then the driver's seat heating / ventilation is switched on again automatically according to the setting before switching off the ignition.

! WARNING

If you have a limited pain and / or temperature sensitivity, e.g. due to medication, paralysis or because of chronic illness (e.g. diabetes), we recommend that you do not use the seat heating. If the seat heating is used, we recommend to make regular breaks in your journey when driving long distances, so that the body can recuperate from the stress of the journey. Please consult your doctor, who can evaluate your specific condition.

! CAUTION

The following instructions must be observed to avoid damage to the seats.

- Do not kneel on the seats or otherwise apply concentrated pressure to them.
- Do not heat seats that do not contain occupants.
- Do not heat seats in which objects are secured or resting (e.g. children's seat, a bag etc.).
- Do not heat seats on which additional slipcovers or protective covers are fitted.

Front and rear seats with seat heating

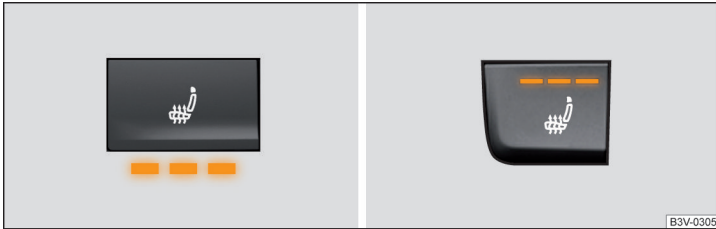

Fig. 101 The seat heating is switched on at maximum heat: Front seats/rear seats

Read and observe **!** and **!** on page 89 first.

› To turn on the heating with maximum heat » Fig. 101, press button or .

With repeated pressing of the button, the level is down-regulated until it switches off. The level of the seat heating is indicated by the number of illuminated warning lights underneath / in the button.

Increase in heating power of the rear seat heating can be locked/unlocked. To do this, press button MENU on the Climatronic → Tap the function surfaces on the Infotainment screen (applies to vehicles with Climatronic controls in the rear). In the locked heating power increase, the heating power can only be adjusted down to turn off.

Front seats with heating and ventilation

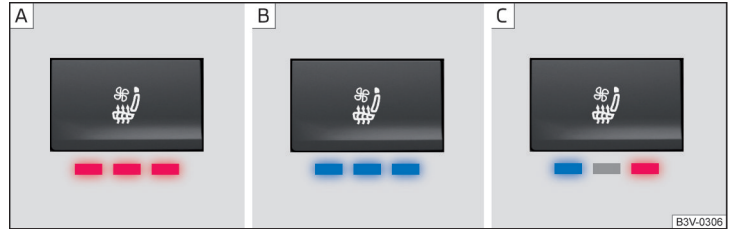

Fig. 102 Heating switched on / ventilation switched on / heating and ventilation are switched on simultaneously









Fig. 103 Infotainment screen: Front seat heating and ventilation with maximum heating / ventilation level switched on



Read and observe **!** and **!** on page 89 first.

› Press the button or on the control panel of the air conditioner, a menu for operating the front seat heating and ventilation is displayed on the Infotainment screen » Fig. 103.





- A** Function surfaces for setting the ventilation level
- B** Function surfaces for setting the heating power
- OFF** Functional surfaces for switching off the ventilation (in addition to the function surfaces **A**) or for switching off the heating (in addition to the function surfaces **B**)

If the seat heating was switched on before the ignition was switched off, then pressing the buttons  and  will switch the seat heating » Fig. 102 on with maximum output .

If the seat ventilation was switched on before the ignition was switched off, then pressing the buttons  and  will switch the seat ventilation » Fig. 102 on with maximum ventilation output .

By repeatedly pressing the button  or , the heating or ventilation output is controlled down to off. The power of the seat heating is indicated by the number of illuminated warning lights underneath the switch.

Only the heating or ventilation can be operated using the buttons  or .

If ventilation and heating are switched on simultaneously on the Infotainment screen, under each button  or  the blue and red warning light illuminates » Fig. 102 - , the button  or  is not functioning (as long as the ventilation and the heating are switched on simultaneously).

Heated steering wheel





Fig. 104 Steering wheel heating: Manual air conditioning/Climatronic

Switching heating on/off (applies to the manual air conditioning)

- › In the Infotainment system, in menu  tap the function surface  » Fig. 104.

Switching heating on/off (applies to Climatronic)

- › Press the button **MENU** on the Climatronic, then tap the function surface ¹⁾ on the Infotainment screen » Fig. 104.

When the heating is switched on, the symbol in the function surface  is or-ange.

The heated steering wheel only works when the engine is running.

Setting the heating power (applies to the Climatronic)

- › Press the button **MENU** on the Climatronic, then tap the function surface  → *Steering wheel heating* on the Infotainment screen.
- › Setting the heating power.

The heating power is displayed by the number of segments in the indicator light  » Fig. 104.

Steering wheel heating together with the driver's seat heating (applies to the Climatronic)

- › To **activate / deactivate** the heated steering wheel with the driver's seat heating, press the button **MENU** on the Climatronic, then tap the function surface  → *Link seat/steering wheel heating* in the Infotainment screen.
- › To **switch on / off** the heated steering wheel, press the button for the driver seat heating.

If the heated steering wheel is turned on together with the driver's seat heating, then the function surface  is displayed on the Infotainment screen. This can be used to switch the heated steering wheel off/on.

¹⁾ Depending on the equipment, one of the function surface versions is displayed.

Practical features

Passenger compartment features

Introduction

! WARNING

- Do not place anything on the dashboard. These objects might slide or fall down when driving and may distract you from concentrating on the traffic – risk of accident!
- Make sure that while driving no objects can enter the driver's footwell – cause an accident!
- Do not carry any objects on the front passenger seat except objects designed for this purpose (e.g. child seats) – risk of accident!
- No objects should be placed in the storage compartments nor in the drinks holders; the vehicle occupants could be endangered if there is sudden braking or the vehicle collides with something.
- For safety reasons, lockable storage compartments must be closed while driving – there is a risk of injury from the opened cover or from the items in the compartment.
- Make sure that no objects protrude from the compartments – there is danger of injury!
- Do not exceed the permissible load for the storage compartments and pockets – it may cause injury or there is the risk of damaging the compartments and pockets!
- Ash, cigarettes, cigars and the like may only be placed in the ashtray – risk of fire!
- The storage compartments and the waste containers are not a substitute for the ashtray and must also not be used for such purposes – risk of fire!

! CAUTION

No not place large or sharp objects in the storage compartments and pockets – there is a risk of damage to the compartments and pockets.

Parking ticket holder



Fig. 105
Parking ticket holder

Read and observe **!** and **!** on page 92 first.

The ticket holder is provided for the attachment of e.g. parking tickets.

Storage compartment on the driver's side

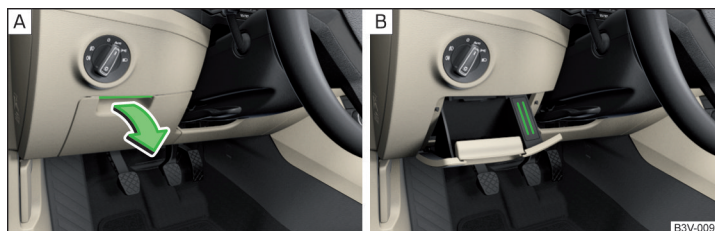

Fig. 106 Opening the storage compartment / card holder

Read and observe **!** and **!** on page 92 first.

- To **open**, lift the handle and fold out the compartment » Fig. 106 **A**.
- To **close**, swing the lid against the direction of the arrow until it audibly clicks into place.

A card holder is located in the storage compartment » Fig. 106 **B**.

The maximum permissible load of the storage compartment is 0.5 kg.

Storage compartments in the doors



Fig. 107 Storage compartments: in the front door/in the rear door

Read and observe **!** and **!** on page 92 first.

Storage compartments » Fig. 107

A Storage compartment

B Bottle holder with a capacity of max. 1.5 l

The reflective vest can be stowed in the storage compartments in the door » page 281.

! WARNING

The storage compartment **A** » Fig. 107 in the front door is to be used exclusively for storing objects which do not protrude - there is the danger of limiting the operating range of the side airbags.

Storage compartment in the front centre console

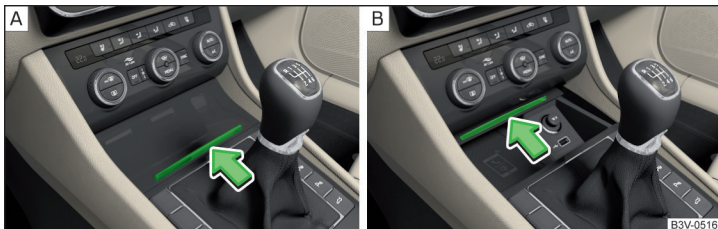

Fig. 108 Storage compartment: Open/close

Read and observe **!** and **!** on page 92 first.

- » To **open**, press the ridge in the direction of arrow » Fig. 108 - **A**.
- » To **close**, press the ridge in the direction of arrow » Fig. 108 - **B**. The lid closes automatically.

Phonebox



Fig. 109
Phonebox

Read and observe **!** and **!** on page 92 first.

The storage compartment in the front centre console can be equipped with the Phonebox function.

If a phone is placed face up on the pad in the storage compartment » Fig. 109, the phone signal is amplified by the roof antenna.

Telephones that support the standard for wireless Qi charging can be charged wirelessly in the storage compartment.

While wireless charging is taking place, **no** objects may be between the pad and the telephone being charged.

! WARNING

- The telephone may become warm during wireless charging, so this should be removed carefully from the tray.
- Metal objects between the pad and the telephone to be charged can get hot due to the action of the induction field - There is a risk of injury. If there is a metal object in the storage compartment that has become hot, then take out the telephone and let the object cook in the storage compartment!

! CAUTION

- Metal objects between the pad and the telephone to be charged can get hot due to the action of the induction field - There is a risk damage to the telephone.
- With some telephones, the charging process may be interrupted or the telephone may switch off due to getting hot.
- No electronic or magnetic storage media (e.g. SD cards, USB sticks, cards with magnetic strips or chip) may be placed between the support and telephone to be charged - there is a risk of data loss and damage to this data carrier.
- If a message appears in Infotainment that the telephone can not be charged, then proceed as follows.
 - Check that no objects are between the pad and the telephone being charged. If this is the case, then take out the object and the telephone. Place the telephone on the pad centrally on the telephone symbol.
 - Check if the position of the telephone to be charged has not changed during the journey. If this is the case, then take out the telephone and place it back on the pad centrally on the telephone symbol.

i Note

- At the start of the wireless charging process, the appropriate message appears on the Infotainment screen.
- For the optimum telephone signal strength and uninterrupted wireless charging, we recommend position the telephone in the storage compartment without the protective sleeve, if possible.
- Place a max. 146x80 telephone in the storage compartment.

USB inputs



Fig. 110 Front USB input / USB input under the armrest



Fig. 111
Rear USB inputs

Read and observe and on page 92 first.

The USB input is located in the storage compartment in the center console and also depending on the equipment fitted, in the storage compartment under the front armrest » Fig. 110.

The USB inputs are also in the rear centre console depending on the equipment fitted » Fig. 111.

The USB input in the storage compartment in the front centre console and in the storage compartment under the front armrest can be used for charging and data transfer. The USB inputs in the rear centre console can be used only for charging.

Information for use » page 153, USB input.

Cup holders



Fig. 112 Open front cup holders/ front cup holders



Fig. 113 Open rear cup holders/ rear cup holders

📖 Read and observe **!** and **!** on page 92 first.

Front cup holder

The cup holder **B** is located in the front centre console » Fig. 112.

- To open, push on the ridge **A** in the direction of the arrow.
- To close, pull on the ridge **A** against the direction of the arrow.

In the centre area of the holder **B**, a beverage container can be opened with one hand by pushing the container into the holder and turning the lid.

Rear cup holder

Two cup containers can be placed in the cup holder **B** » Fig. 113.

- To open, hold the lid on the recess **A** and fold in the direction of arrow until the stop.
- To close, push the cover against the direction of the arrow.

! WARNING

- Do not use any cups or beakers which are made of brittle material (e.g. glass, porcelain). This could lead to injuries in the event of an accident.
- Never put hot beverage containers in the cup holder. If the vehicle moves, they may spill – risk of scalding!

! CAUTION

Do not leave open beverage containers in the cup holder during the journey. There is a risk of spilling e.g. when braking which may cause damage to the electrical components or seat upholstery.

Waste container

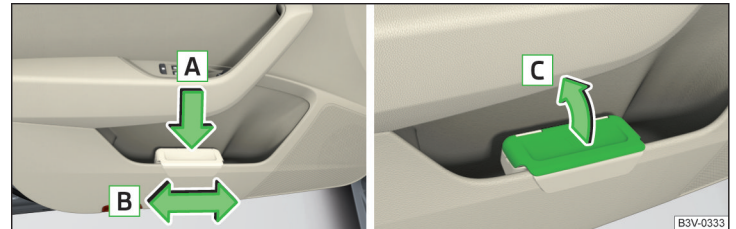

Fig. 114 Waste container: inserting and moving/opening

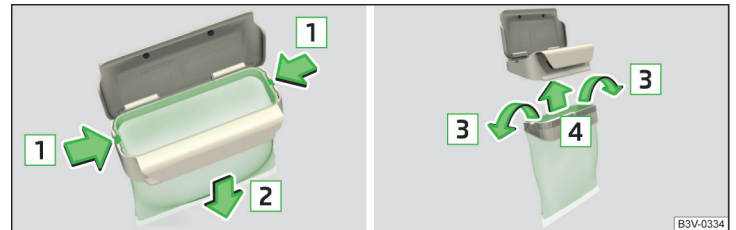

Fig. 115 Replace bags

📖 Read and observe **!** and **!** on page 92 first.

The waste container can be inserted into the slot in the door.

Insert waste container

- Position the waste container at the front edge of the slot.
- Push the waste container in the rear area in the direction of the arrow **A** » Fig. 114.
- If required, push the waste container in the direction of arrow **B**.

Remove the waste container

- Remove the waste container in the opposite direction to the arrow **A** » Fig. 114.

Open/close waste container

- Lift the cover in the direction **C** » Fig. 114.

Closing takes place in reverse order.

Replace bags

- Remove the waste container from the slot.
- Press the two locking lugs on the frame in the direction of arrow **1** » Fig. 115.
- Pull the bag together with the frame downwards in the direction of arrow **2**.
- Remove the bag from the frame.
- Pull the new bag through the frame and pull it over the bag frame in the direction of arrow **3**.
- Insert the bag containing the frame in the direction of arrow **4** into the container body, so that the two lugs engage audibly with the frame.

i Note

We recommend that you use 20 x 30 cm bags.

Storage compartment underneath the front armrest



Fig. 116 Open tray / control air supply

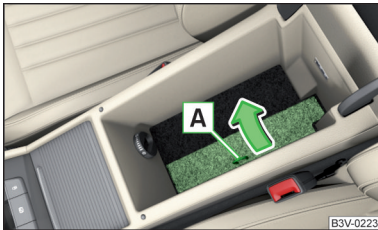

Fig. 117
Open storage compartment for the tablet

Read and observe **!** and **!** on page 92 first.

The storage compartment is equipped with an interior light (this is illuminated when the parking lights / low beam are switched on), a stowage compartment for the tablet and an air outlet.

Storage compartment

- To **open**, lift the armrest in the direction of arrow **1** » Fig. 116 until it stops.
- To **close**, fold the armrest down again against the direction of the arrow **1**.

Storage compartment for the tablet

- To **open**, pull on the loop **A** in the direction of arrow » Fig. 117.
- Place the tablet carefully to avoid damage to any connected cables.

Air supply

- To **open**, turn the rotary switch until it stops in the position » Fig. 116.
- To **close**, turn the rotary switch until it stops in the position **O**.

The temperature of the storage compartment supplied with air is dependent on the setting in the air conditioning.

Glasses storage box

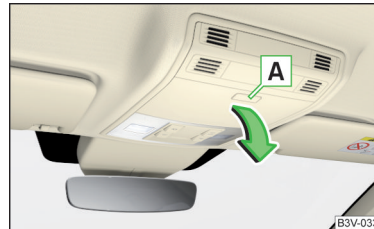

Fig. 118
Opening the glasses storage box

Read and observe **!** and **!** on page 92 first.

- To **open**, press the -- button. The compartment folds in the direction of the arrow » Fig. 118.
- To **close**, swivel the compartment against the direction of the arrow until it audibly clicks into place.

The maximum permissible load of the glasses compartment is 250 g. ▶

! CAUTION

- Do not put any heat-sensitive objects in the glasses storage box - with high temperatures there is risk of damage.
- The box must be closed before leaving and locking the vehicle – risk of impairment to the functions of the anti-theft alarm system.

Storage compartment on the front passenger side

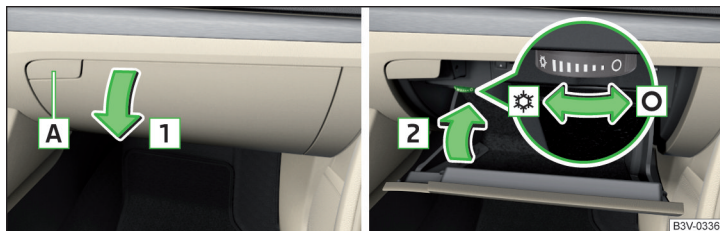

Fig. 119 Open storage compartment / close storage compartment and open air supply

📖 Read and observe ! and ! on page 92 first.

The storage compartment is equipped with an interior light (this is illuminated when the parking lights / low beam are switched on), a pen holder and an air outlet.

Storage compartment

- To open, press the -- button. The cover folds in the direction of arrow **1** » Fig. 119.
- To close, swivel the cover in the direction of arrow **2** until it audibly clicks into place.

Air supply

- To open, turn the rotary switch until it stops in the position ⚙️ » Fig. 119.
- To close, turn the rotary switch until it stops in the position ○.

Opening the air supply when the air conditioning system is switched on allows cooled air to flow into the storage compartment.

Opening the air inlet when the air conditioning system is on causes fresh or interior air to flow into the storage compartment.

The maximum permissible load of the storage compartment is 3 kg.

Storage compartment under the front passenger's seat



Fig. 120
Opening the storage compartment

📖 Read and observe ! and ! on page 92 first.

- To open, pull the handle in direction of arrow **1** pull and open the compartment in the direction of arrow **2** » Fig. 120.
- To close, pull the handle in the direction of arrow **1** and hold this against the direction of arrow **2** until the storage compartment closes.

The maximum permissible load of the storage compartment is 1.5 kg.

Storage compartments for umbrellas



Fig. 121
Storage compartment for an umbrella - view example in the left door

📖 Read and observe ! and ! on page 92 first.

The storage compartments in the front doors » Fig. 121 can be used to store an umbrella.

Clothes hook

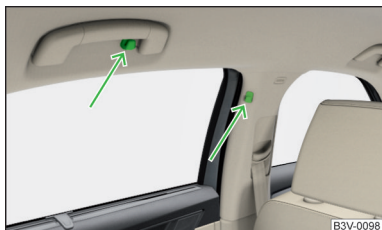

Fig. 122
Clothes hooks

Read and observe **!** and **!** on page 92 first.

The clothes hooks are located on the middle door pillars of the vehicle and on the handle of the headliner above each of the rear doors » Fig. 122.

The maximum permissible load of each of the hooks is 2 kg.

! WARNING

- Never leave any heavy or sharp-edged objects in the pockets of the items of clothing hung up.
- To hang the clothes do not use hangers - there is a risk of limiting the effectiveness of head airbags.
- Ensure that any clothes hanging from the hooks do not impair your vision to the outside.

Storage pockets on the backs of the front seats



Fig. 123
Map pockets

Read and observe **!** and **!** on page 92 first.

The map pockets are intended for storage of maps, magazines, etc.

Storage pockets at the inner sides of the front seats



Fig. 124
Storage pocket

Read and observe **!** and **!** on page 92 first.

The storage pockets are located on the inside of the driver, if necessary, also the front passenger seat » Fig. 124 and are used to store small and light objects (e.g. mobile telephones).

The maximum permissible load of each of the pockets is 200 g.

Storage compartment in rear centre console

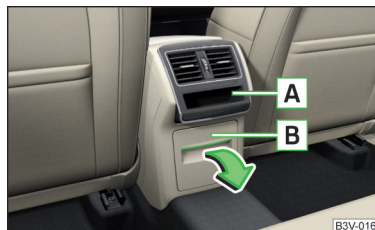

Fig. 125
Open storage compartment,
open lockable storage compartments

Read and observe **!** and **!** on page 92 first.

In the rear centre console there is an equipment-dependent open storage compartment **[A]** and a lockable storage compartment **[B]** » Fig. 125.

- To **open**, pull the storage compartment **[B]** on the upper part of the recess and fold down the compartment in the direction of arrow » Fig. 125.
- To **close**, swivel the compartment against the direction of the arrow.

There is a cushioned insert in the storage compartment. This can be removed if the storage compartment is opened to the stop.

Storage compartment in the rear armrest



Fig. 126 Open storage compartment / interior of the compartment

Read and observe **!** and **!** on page 92 first.

The storage compartment provides a cup holder **B**, a stowage compartment for attaching the tablet holder **C** as well as a pen holder **D** » Fig. 126.

- ▶ To **open**, hold the lid on the recess **A** and fold in the direction of arrow until the stop.
- ▶ To **close**, push the cover against the direction of the arrow.

Long cargo channel

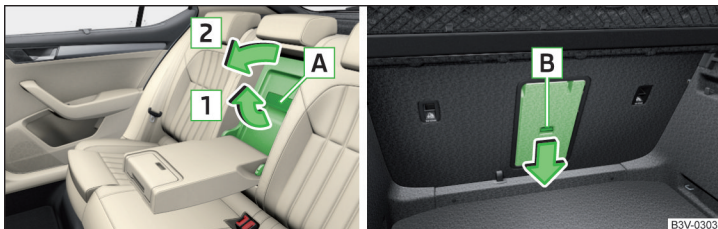

Fig. 127 Open lid: from the passenger compartment / from the luggage compartment

Read and observe **!** and **!** on page 92 first.

- ▶ To **open from the passenger compartment**, fold down the rear armrest slightly » page 87.

- ▶ Pull opening lever **A** » Fig. 127 in the direction of arrow **1** until it stops. The catches on the cover must engage completely in the lid and click into place.
- ▶ Open the cover in the direction of the arrow **2**.
- ▶ To **open from the luggage compartment**, push the securing tab **B** in the direction of the arrow and fold the cover with the armrest forwards.
- ▶ To **close**, fold the cover and the rear armrest upwards until the stop. This should audibly click into place.

The cover must be secured after the closing process. Ensure that the red field above the securing tab **B** is not visible.

! WARNING

The through-loading channel is only intended for transporting skis in a properly secured, through-loading bag.

Removable through-loading bag



Fig. 128 Tighten ribbon / secure bag

Read and observe **!** and **!** on page 92 first.

The removable through-loading bag (hereinafter referred to as bag) is used exclusively for transporting skis and poles (max. 4 pairs).

Stowing bag and skis

- ▶ Fold the rear armrest and the cover in the seat backrest downwards » Fig. 127 on page 99.
- ▶ Place the empty bag in the opening in such a way that the end of the bag with the zip is in the boot.
- ▶ Place the skis **with the tips facing to the front** and the sticks with the tips facing to the rear into the bag and close the bag.

Securing bag and skis

- ▶ Tighten the strap **A** around the skis in front of the bindings » Fig. 128. The strap must hold the skis tight.
- ▶ Partially fold the middle seat backrest forward » page 87.
- ▶ Guide the securing strap **B** through the opening in the seat backrest around the upper part of the seat backrest.
- ▶ Then, fold the seat backrests back until the locking button clicks into place. Check this by pulling on the seat backrest.
- ▶ Insert the securing strap **B** into the lock **C** until it clicks into place.

! WARNING

- The total weight of the skis which are transported must not exceed 17 kg.
- Always stow and secure the skis and the bag securely - otherwise there is a risk of injury or accident!

Blanket

📖 Read and observe **!** and **!** on page 92 first.

To increase comfort for the occupants, the vehicle may be equipped with a blanket.

The blanket is in a bag that can be attached to one of the following locations.

- ▶ On the guide rods of the front headrests.
- ▶ In the storage pockets on the backs of the front seats.

Electrical sockets

📖 Introduction

! WARNING

- Do not place anything on the dashboard. These objects might slide or fall down when driving and may distract you from concentrating on the traffic – risk of accident!
- Make sure that while driving no objects can enter the driver's footwell – cause an accident!
- Safely stow all devices during the journey to prevent them from being thrown around the interior in the event of a sudden braking manoeuvre or an accident – risk of death!
- The devices may warm up during operation – risk of injury or fire!

! WARNING (Continued)

- Improper use of the power sockets and the electrical accessories can cause fires, burns and other serious injuries.
- The 12-Volt sockets also work if the ignition is switched off. When leaving the vehicle, never leave persons who are not completely independent, such as children, unattended in the vehicle.

! CAUTION

When using the 12 volt power outlets the following notes are to be observed.

- The sockets can only be used for the connection of approved electrical accessories with a total power consumption of up to 120 watts, otherwise the electrical system of the vehicle may be damaged.
- Connecting appliances when the engine is not running will drain the battery of the vehicle!
- Before switching the ignition on / off or before starting the engine, switch off the devices which are connected to the sockets - there is a risk of damage to the equipment due to voltage fluctuations.

12-volt socket in the front centre console



Fig. 129
Cover of the 12 volt power outlet

📖 Read and observe **!** and **!** on page 100 first.

- ▶ To use, open the storage compartment, remove the cover of the socket » Fig. 129 and plug the electrical appliance plug into the socket.

12 volt socket in the rear centre console



Fig. 130 Open storage compartment / cover of the 12 volt power outlet

Read and observe  and  on page 100 first.

- To use, open the storage compartment, remove the cover of the socket » Fig. 130 and plug the electrical appliance plug into the socket.

12 volt socket in luggage compartment



Fig. 131
Cover of the 12 volt power outlet

Read and observe  and  on page 100 first.

- To use, open the cover of the socket » Fig. 131 and plug the electrical appliance plug into the socket.

230-volt socket in the rear centre console



Fig. 132 Open the cover of the 230 volt outlet / 230 volt outlet

Read and observe  and  on page 100 first.

The 230-volt socket has a child safety lock. When inserting the plug, the fuse is released, the socket is activated and the warning light above the socket is illuminates green (if this flashes red, then the socket is deactivated).

The socket works with the engine running (in STOP mode in vehicles with the START-STOP system) and for about 10 minutes after the engine is switched off, provided an appliance was still connected prior to switching off the engine (the warning light flashes green)).

- To use, fold up the cover of the socket in the direction of arrow » Fig. 132 and plug the electrical appliance plug into the socket.

An automatic deactivation of the socket can take place, for example, for the following reasons.

- Excessive current.
- Low state of charge of the battery.
- High outlet temperature.

If disabling reasons no longer exist, the automatic activation of the socket can be done.

Should no automatic activation of the socket take place, the connected devices must be disconnected from the power outlet and reconnect after a short time.

! WARNING

- Make sure that no liquid or moisture enters into the socket - it can be fatal! If fluid does manage to get into the power socket, completely dry out the socket before reuse.
- The child lock on the power socket is unlocked when using adapters and extension cables which carry volts – risk of injury!
- Do not insert any objects (e.g. knitting needles) into the contacts of the power socket – risk of death!

! CAUTION

- The power socket can only be used for connecting approved electrical accessories with a two-pin 230V plug, with a total power uptake of up to 150 watt.
- The plug of the electrical appliance must be plugged in up to the stop, otherwise the child safety lock can be unlocked and the socket may be activated but the electric appliance is still not receiving power.
- Do not connect bulbs with neon tubes in the socket - there is a risk of damaging the lamp.
- For appliances with an independent power source (e.g. such as notebooks), first connect the power source itself and only after that connect the appliance.

Ashtray and cigarette lighter

📖 Introduction

The ashtray can be used for ash, cigarettes, cigars and the like.

! WARNING

- Never place hot or flammable objects in the ashtray – risk of fire!

Ashtray

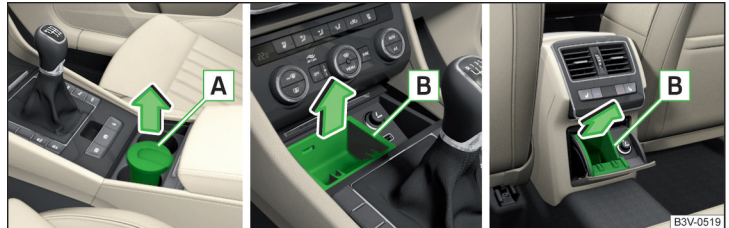

Fig. 133 Remove front ashtray / remove front ashtray insert / remove rear ashtray insert

📖 Read and observe ! on page 102 first.

Removable ashtray

- Hold the ashtray **A** (not by the lid) **remove** it in the direction of the arrow » Fig. 133.

To **insert**, proceed in reverse order.

Ashtray with removable insert

- To **remove** the insert, open the ashtray fully, hold the insert in area **B** and **remove** in the direction of the arrow » Fig. 133.

To **insert**, proceed in reverse order.

Cigarette lighter



Fig. 134 Cigarette lighter: in the front centre console/in the rear centre console

Read and observe **!** on page 102 first.

- To use, open the respective storage compartment and push in the lighter until it stops» Fig. 134.
- Wait until the glowing lighter protrudes, remove it immediately and use.
- Put the lighter back in the socket and close the storage compartment.

! WARNING

- The cigarette lighter also works if the ignition is switched off. When leaving the vehicle, never leave people who are not completely independent, such as children, unattended in the vehicle - there is a risk of burning, fire or damage to the vehicle interior.
- Be careful when using the cigarette lighter - it can cause burns.

i Note

The cigarette lighter socket can also be used as a 12 volt socket.

Tablet holder

Introduction

External devices (e.g. tablet, smartphone etc.) measuring min. 122 mm and max. 195 mm can be secured in the holder.

The maximum permissible load of the compartment is 750 g.

! CAUTION

Never exceed the maximum permissible load of the holder - there is a risk of damage or functional impairment.

Attaching the rear headrests



Fig. 135 Inserting: Adapter/Holder

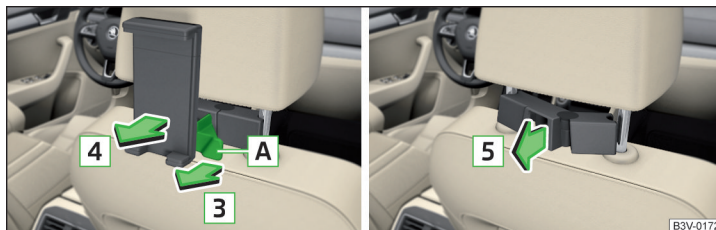

Fig. 136 Removal: Holder/Adapter

Read and observe **!** on page 103 first.

- To insert, attach the opened adapter to the guide rods of the front headrest and clip in the direction of arrow **1**» Fig. 135 » **!**
- Clip in the holder in the direction of arrow **2** into the adapter.
- To remove, pull on the securing tab **A** in direction of arrow **3** and take the holder out of the adapter in the direction of arrow **4**» Fig. 136.
- Press the adapter and remove in the direction of the arrow **5** from the guide rods of the headrest.

! WARNING

Be care with the adapter - otherwise there is a risk of finger injury.

Attach to the storage compartment in the rear armrest

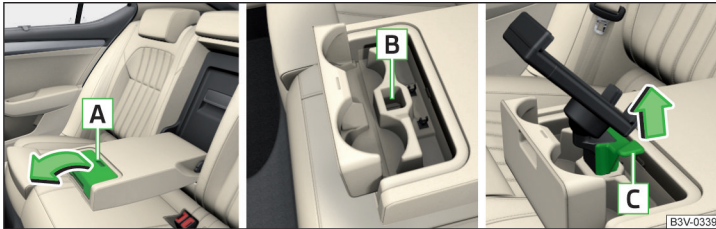

Fig. 137 Open storage compartment / stowage compartment for holder / remove holder

Read and observe on page 103 first.

- ▶ To **insert**, hold the lid on the recess **A** and fold open in the direction of arrow » Fig. 137.
- ▶ Insert the holder in the stowage compartment **B** until it stops.
- ▶ To **remove**, pull the securing tab **C** in direction of arrow and take the holder in direction of arrow out of the adapter.
- ▶ Fold the cover closed against the direction of the arrow.

Handling the holder

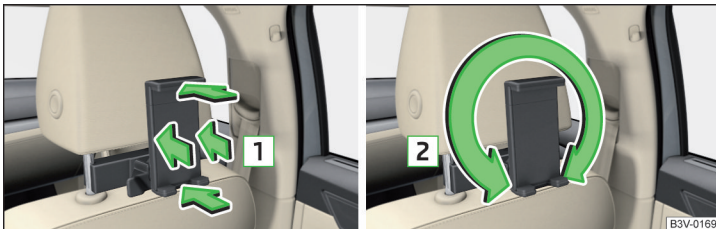

Fig. 138 Tilting and rotating the holder

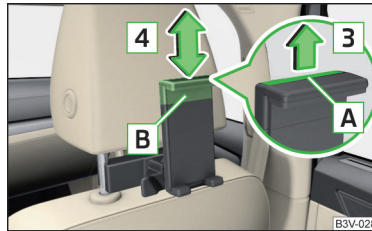

Fig. 139
Adjusting the holder size

Read and observe on page 103 first.

The holder may be by 30° in the direction of the arrow **1** tipped and by 360° in the direction of arrow **2** turned » Fig. 138.

- ▶ To **adjust the holder size**, pull out the securing tab **A** in the direction of arrow **3** and push the part **B** in the direction of arrow **4** to the desired position » Fig. 139.

Note

If there is no external device in the holder, then we recommend that the part **B** is moved fully down. Otherwise, irritating noises may occur at certain speeds.

Transport of cargo

Luggage compartment

Introduction

When transporting heavy objects, the driving characteristics change due to the shift in centre-of-gravity. Therefore, adjust the speed and driving mode accordingly.

When transporting cargo the following the instructions must be adhered to

- ▶ Distribute the load evenly in the luggage compartment and secure it with suitable lashing straps to the lashing eyes or securing nets so that they cannot slip.
- ▶ Place heavy objects as far forward in the luggage compartment as possible.
- ▶ Tyre pressure is to match the load.

In the event of an accident, even small and light objects gain so much kinetic energy that they can cause severe injuries.

The magnitude of the kinetic energy is dependent on the speed at which the vehicle is travelling and the weight of the object.

Luggage compartment light

The light switches on/off when the boot lid is opened or closed.

If the boot lid is open and the ignition switched off, the light will extinguish automatically after around 10 minutes.

! WARNING

- Never exceed the maximum permissible load of the respective fasteners, nets, hooks etc. Heavy objects were not secured sufficiently – risk of injury!
- An unfixed or improperly fixed load can slip during a sudden manoeuvre or an accident - danger of injury!
- Loose cargo could hit a deployed airbag and injure occupants – danger of death!
- When transporting loads in the luggage compartment that has been enlarged by folding the rear seats forward, ensure the safety of the passengers transported on the other rear seats .

! CAUTION

- Never exceed the maximum permissible load of the respective fasteners, nets, hooks etc. - these could be damaged.
- Make sure that the heating elements of the rear window heater, the elements of the integrated aerial in the rear window or in the rear side windows are not damaged by abrasive items.
- Do not place sharp objects in the nets and storage compartments in the luggage compartment - there is a risk of damage to the net as well as the compartments.
- Put the items in the storage compartments carefully and not load these punctiform - there is a risk of damage to the compartments.

Fastening elements

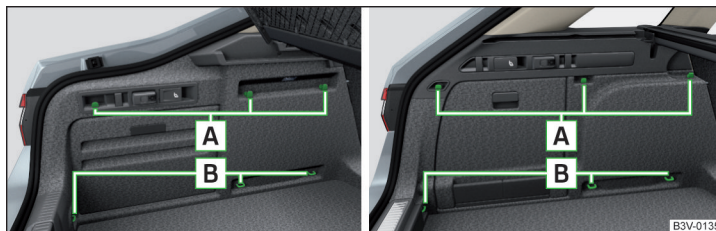

Fig. 140 Fastening elements: Version 1/version 2

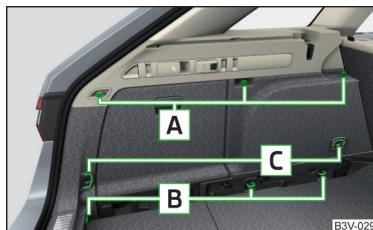

Fig. 141
Fastening elements: Variant 3

! Read and observe ! and ! on page 105 first.

The fasteners are located on both sides of the luggage compartment. ▶

Overview of the fastening elements » Fig. 140 and » Fig. 141

- A** Fastening elements **only** for fastening fixing nets
- B** Lashing eyes for fastening cargo and securing nets
- C** Lashing eyes for fastening cargo and securing nets

The maximum permissible static load for the individual lashing eyes **B** and **C** is 350 kg.

Fixing nets

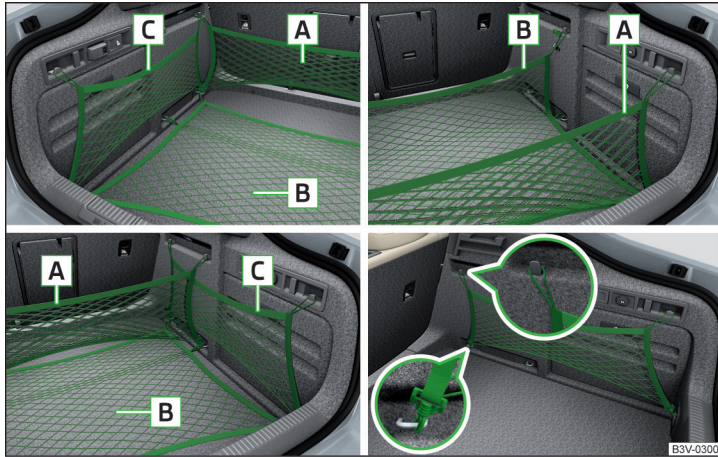

Fig. 142 Fastening examples for nets / side pocket fastening

Read and observe **!** and **!** on page 105 first.

Fastening examples for nets » Fig. 142

- A** Horizontal pocket
- B** Floor net
- C** Vertical pocket

The maximum permissible load of each of the nets is 1.5 kg.

If the vehicle is equipped with the variable loading floor and this is in the upper position, then the lashing eyes **C** » Fig. 141 on page 105 can be used to attach the nets.

Foldable hook

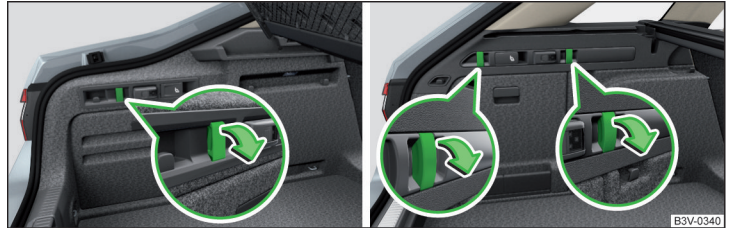

Fig. 143 Fold down the hook: Version 1/version 2

Read and observe **!** and **!** on page 105 first.

Foldable hooks for hanging small items of luggage, such as bags, etc., are provided on both sides of the luggage compartment.

► To use it, pull down the hook in the direction of the arrow » Fig. 143.

The maximum permissible load of the hook is 7.5 kg.

Fasten the flooring

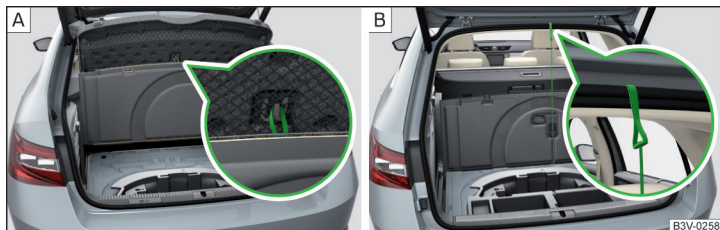

Fig. 144 Fixing the floor covering: Version 1/version 2

Read and observe **!** and **!** on page 105 first.

Fastening options for the flooring » Fig. 144

- A** With the loop on a hook on the luggage compartment cover
- B** With the hook on the frame of the luggage compartment lid

! CAUTION

For version 1, the following information applies.

- The hook on the luggage compartment cover is only provided for the fixing of the floor covering, do not hang objects on it - there is a risk of damage to hook.
- The flooring covering can be fixed to the hook only with the boot open. Before closing the lid, check that the flooring is not attached to the hook - there is a risk of damage to the hook.

! CAUTION

The floor covering can be fixed with Version 2 only if the variable loading floor is folded in the upper position » Fig. 161 on page 114.

Floor covering on both sides

Read and observe **!** and **!** on page 105 first.

A double-sided floor covering can be fitted in the luggage compartment. One side is made of fabric, the other side is washable (suitable for transporting wet or dirty items).

Net on the luggage compartment cover



Fig. 145
Net on the luggage compartment cover

Read and observe **!** and **!** on page 105 first.

The net at the bottom of the luggage compartment cover » Fig. 145 is provided for transporting light and soft items.

The maximum permissible load of the net is 1.5 kg.

Luggage compartment cover

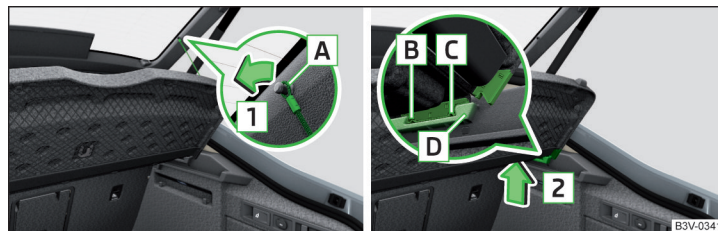

Fig. 146 Remove the luggage compartment cover



Fig. 147
Luggage compartment cover
stowed behind the rear seats

Read and observe **I** and **II** on page 105 first.

If the retaining straps **A** » Fig. 146 are attached to the boot lid, then opening the lid will also raise the luggage compartment cover (hereafter only referred to as "cover").

The cover can be removed from the vehicle and stowed behind the rear seat backrests if required » Fig. 147. Before removing the cover, the sunshade at the back must be rolled up » page 78.

Removing

- › On both sides of the boot lid, unhook the straps **A** in the direction of arrow **1** » Fig. 146.
- › Hold the raised cover and press on the two sides on the underside of the cover in the area of the recess **C**.
- › Remove the cover in the direction of the arrow **2**.

Fitting

- › First, insert the front mounting **B** and then the rear mounting **C** in the recess **D** » Fig. 146.
- › Press on the two sides on the upper side of the cover in the area of the recess **D**. The mountings **B** and **C** must engage with the recess **D** on both sides of the luggage compartment.
- › On both sides of the boot lid unhook the straps **A**.

! WARNING

During the trip there must be no objects on the cover - risk of injury in the event of sudden braking or a vehicle collision!

! CAUTION

- › Observe the following instructions to avoid canting and the subsequent damage to the cover or the side trim.
 - › The cover must be inserted properly and the load must not exceed the height of the cover.
 - › The cover must not be jammed in the surrounding seal of the luggage compartment lid when it is in the raised position.
 - › There must be no object in the gap between the cover in the raise position and the rear backrest.
- › Never fold the raised cover forwards to the rear seats - there is a risk of damaging the cover and the boot lid.

Roll-up cover

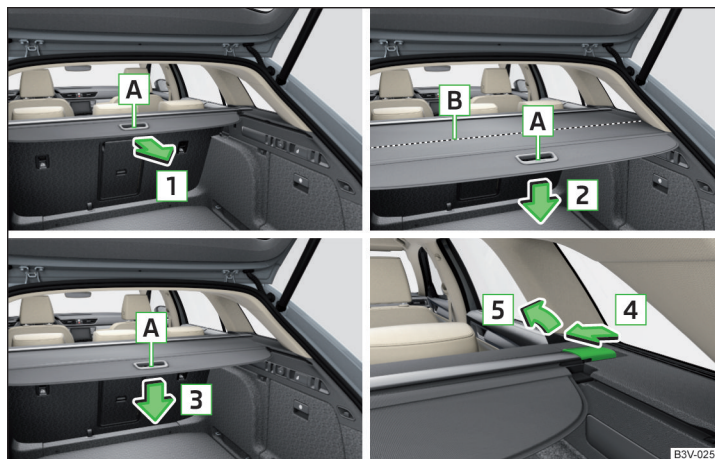

Fig. 148 Roll-up cover: pull out/roll up/intermediate position/remove



Fig. 149 Remove the left side cover / store roll-up cover

📖 Read and observe **!** and **!** on page 105 first.

Extending

- Grasp the cover at grip-point **A** and pull it out in the direction of the arrow **1** until it audibly clicks into place» Fig. 148.

Retracting

- Push the cover in the handle area **A** in the direction of arrow **2**. The cover rolls up automatically to the intermediate position **B** » Fig. 148.

The cover rolls up fully by pressing the cover in the handle area **A** in direction of arrow **3**. The rolled-up cover can now be removed.

Removing/inserting

- Press on the side of the cross bar in the direction of arrow **4** and remove the cover in the arrow direction **5** » Fig. 148.

Insertion takes place in reverse order.

Stowage

If the vehicle is equipped with the variable loading floor, then the removable roll-up luggage compartment cover can be stowed in the recesses of the luggage compartment side trim.

- Fold the variable loading floor into the upper position » page 114.
- Open the side trays on both sides of the luggage compartment and remove » Fig. 150 on page 110 - **B**.
- Remove the left side cover in the arrow direction **1** » Fig. 149.
- Insert the roll-up cover in the recesses of the side trim in the direction of arrow **2** and stow in the direction of arrow **3**.
- Reinsert the left side cover in the opposite direction to the arrow **1**.

- Close the side compartments on both sides of the luggage compartment.
- Fold out the variable loading floor to the upper position.

! WARNING

No objects should be placed on the roll-up cover - there is a risk of damage to the cover and a risk of injury in the event of a sudden stop or a vehicle collision!

! CAUTION

It is possible that the roll-up luggage compartment cover rolls more slowly during winter weather conditions. This is not a defect.

i Note

If you want to stow the roll-up luggage compartment cover and the multifunction pocket **at the same time**, then it is necessary that the rear part of the roll-up luggage compartment **covers** the multifunction pocket.

Roll-up cover - automatic rolling-up

📖 Read and observe **!** and **!** on page 105 first.

The automatic rolling up of the roll-up cover (hereafter as function) eases access to the luggage compartment.

When opening the boot lid with the function activated, the roll-up cover automatic rolls-up of the intermediate position **B** » Fig. 148 on page 108.

Deactivating/activating can be carried out in Infotainment in the **CAR** / **Opening and closing** in progress.

i Note

The setting (activation/deactivation) of the automatic rolling up is stored (depending on the Infotainment type) in the active user account personalisation » page 55.

Side storage compartment and trays



Fig. 150 Side shelf removal / open side pocket

Read and observe **!** and **!** on page 105 first.

Located at the two sides of the luggage compartment, depending on vehicle equipment are side trays » Fig. 150 - [A] or lockable side compartments » Fig. 150 - [B].

The space behind the tray and in the tray is provided for storing small objects up to a total weight of 2.5 kg.

Side compartment

Remove the storage compartment cover in the direction of the arrow » Fig. 150 - [A].

To insert, proceed in reverse order.

Side compartment

To open, pull the handle in direction of arrow **1** and open the compartment in the direction of arrow **2** » Fig. 150 [B]. The tray can be removed.

To close, swivel the compartment against the direction of arrow **2**.

Cargo element



Fig. 151 Taking out cargo elements: Version 1/version 2

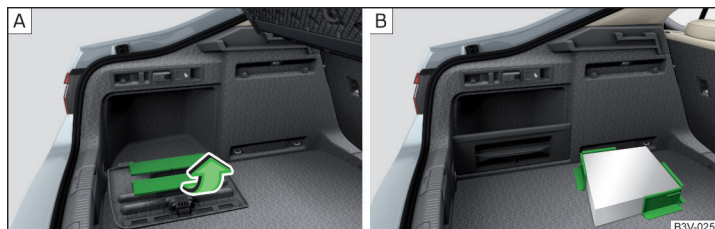

Fig. 152 Taking out cargo elements: Variant 3/load fastening example

Read and observe **!** and **!** on page 105 first.

The cargo elements are designed for mounting and securing loads with a maximum gross weight of 8 kg.

- Before use, remove the Cargo elements in the direction of the arrows » Fig. 151 and » Fig. 152 - [A].
- Use the cargo elements to secure the load as close as possible to the rear seats » Fig. 152 [B].
- After use, stow the Cargo elements in their original position.

Storage compartments under the floor covering



Fig. 153 Variant 1: Lifting floor covering/storage compartments



Fig. 154 Variant 2: Lifting floor covering/storage compartments

📖 Read and observe **!** and **!** on page 105 first.

For vehicles that are not equipped with an emergency spare wheel located under the flooring of the luggage compartment **B** » Fig. 153 or » Fig. 154.

Every storage compartment **B** is designed for storing small objects of up to 15 kg. in weight in total.

Using the storage compartments - variant 1

- › Lift the flooring via loop **A** in the direction of arrow » Fig. 153 and completely fold back or fasten using the loop on the hook on the luggage compartment cover.
- › Stow the cargo in the storage compartments.
- › Fold back the flooring against the direction of the arrow or remove it from the hook.

When transporting tall objects in the compartments, the flooring must be folded forward.

Using the storage compartments - variant 2

- › Dividing the luggage compartment with variable loading floor » page 114.
- › Lift the floor covering in the direction of arrow » Fig. 154 and hook into hook **C** on the upper edge of the variable loading floor.
- › Stow the cargo in the storage compartments.
- › Unhook hook **C** and fold back the flooring against the direction of the arrow (fold back the variable loading floor to the initial position if necessary).

When transporting tall objects in the compartments, the hook **C** must be hooked onto the upper edge of the variable loading floor.

! CAUTION

- Before closing the boot lid check that the flooring is not attached to the hook with the loop **A** » Fig. 153 - there is a risk of damaging the hook.
- Before closing the boot lid, check that the cargo transported in the storage compartments does not strike against the luggage compartment cover - there is a risk of damage to the lid.

Multi-function pocket

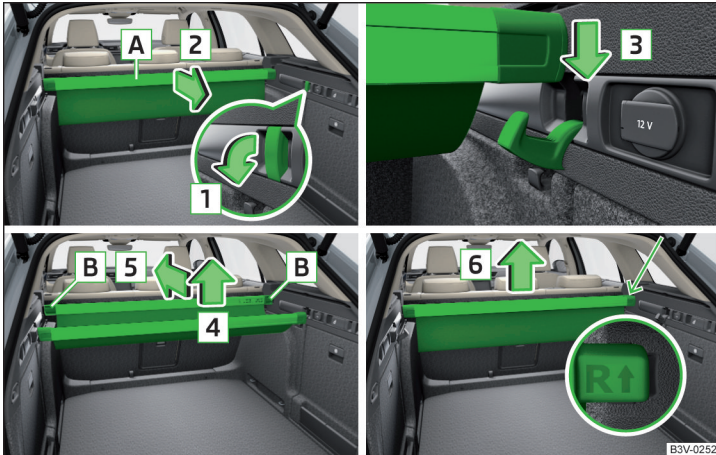

Fig. 155 Multifunction pocket: Pull out/insert/push in/remove



Fig. 156 Remove the left side cover / store multifunction tray

Read and observe **!** and **!** on page 105 first.

The multifunction pocket (following as pocket) is provided for the storage of clothing and light objects with no sharp edges.

The maximum permissible load of the multifunction box is 3 kg.

112 Using the system

Removal and fitting

- › Fold down the front hooks on both sides of the luggage compartment in the direction of arrow **1** » Fig. 155.
- › Grasp the rear bar **A** with both hands and withdraw the pocket in arrow direction **2**.
- › Place the rear bar onto the two hooks that are folded forward in the direction of the arrow **3** all the way to the stop.

Pushing in

- › Remove the rear bar from the hooks in the direction of arrow **4** and push in the pocket in the direction of arrow **5** » Fig. 155.
- › Place the rear bar against the front bar and press them together at both ends **B**.
- › The front hooks on both sides of the luggage compartment fold back opposite to the direction of arrow **1**.

Removing/inserting

- › Remove the roll-up luggage compartment cover » page 108.
- › Remove the pocket from the fittings in the direction of the arrow **6** » Fig. 155.

Insertion takes place in reverse order.

- › Insert the end of the bar marked **R** ↑ in the right-hand mounting, and the end marked **L** ↑ in the left-hand mounting. The arrows should be pointing forward.

Storage

If the vehicle is equipped with the variable loading floor, then the removable pocket cover can be stowed in the recesses of the luggage compartment side trim.

- › Fold the variable loading floor into the upper position » page 114.
- › Open the side trays on both sides of the luggage compartment » Fig. 150 on page 110 - **B**.
- › Remove the left side cover in the arrow direction **1** » Fig. 156.
- › Insert the pocket in the recesses of the side trim in the arrow direction **2** and stow in the direction of arrow **3**.
- › Reinsert the left side cover in the opposite direction to the arrow **1**.
- › Close the side compartments on both sides of the luggage compartment.
- › Fold out the variable loading floor to the upper position.

i Note

If you want to stow the roll-up luggage compartment cover and the multifunction pocket **at the same time**, then it is necessary that the rear part of the roll-up luggage compartment **covers** the multifunction pocket.

Removable light

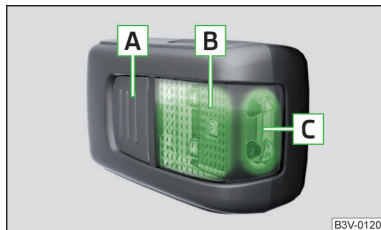

Fig. 157
Removable light

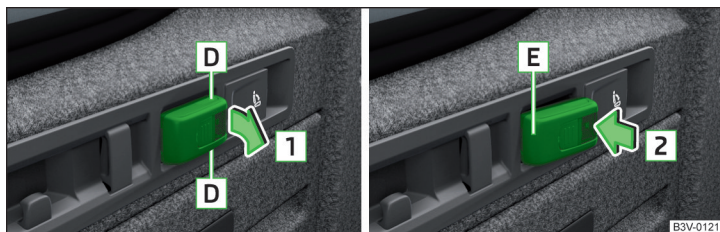

Fig. 158 Removing light/inserting light

Read and observe and on page 105 first.

The lamp is for the illumination of the luggage compartment or it can be used as a portable lamp.

The lamp is equipped with a magnet. As a result, this can, for example, be fitted to the vehicle body.

Description of the light » Fig. 157

A Button to turn the light that has been removed on / off

B Part that lights up when the lamp is in the mount

C Part that lights up when the lamp is not in the mount

If the light is in the **mount**, this will illuminate when the boot lid is opened.

» To **remove**, hold the light in the area **D** and swivel in the direction of arrow **1** » Fig. 158.

» To **switch on** the removed light, press button **A** » Fig. 157. Pressing the light again will **switch it off**.

» To **insert**, first of all insert the light with the rear part **E** into the mount » Fig. 158 and then push the light in the direction of arrow **2** until it audibly clicks into place.

If the light is not switched off and is correctly inserted in the mount, the LED diodes in the front part of the light **C** » Fig. 157 are automatically switched off.

If the lamp is not correctly inserted into the holder, this does not light up when the boot lid is opened and the rechargeable batteries are not charged.

Lamp charges

The lamp is supplied by three rechargeable type NiMH AAA batteries (voltage 1.2 V). The batteries are charged continuously with the engine running (to fully charge the battery takes approximately 3 hours).

Replace batteries » page 292.

CAUTION

The light is not waterproof, so it must be protected from humidity - otherwise there is risk of damage.

Variable loading floor in the luggage compartment (Estate)

Positions of the variable loading floor



Fig. 159 Set variable loading floor to the upper position / variable loading floor in the upper position



Fig. 160 Set variable loading floor to the lower position / variable loading floor in the lower position

The variable loading floor can be set to the upper or lower position.

Set to the upper position

- › Lift the variable loading floor by the handle **A** » Fig. 159 by about 20 cm and pull towards you.
- › Lift the variable loading floor to the height of the roll-up luggage compartment cover in the direction of arrow **1** until you hear the clicking sound and press forward.

The space below the variable loading floor can be used for stowing objects such as the removed roll-up luggage compartment cover » page 108, the multi-function pocket » page 112 etc.

The maximum permissible load of the variable loading floor is 75 kg. For the transport of heavy loads, adjust the variable loading floor in the lower position » Fig. 160.

Set into the lower position

- › Check that the area below the variable loading floor is empty.
- › Lift the variable loading floor by the handle **A** » Fig. 160 above the loading edge in the direction of arrow **2**.
- › Pull the loading floor towards you in the direction of arrow **3** until it sinks to the bottom position, and push forward.

Fold together / fold out the variable loading floor



Fig. 161 Fold up variable loading floor / folded variable cargo floor in the upper position

- › To **fold together**, hold the variable loading floor by the handle **A** and lift in the direction of arrow **1** » Fig. 161.
- › Fold up the variable loading floor by moving it in the direction of the arrow **2**.

Folding out takes place in reverse order.

The variable loading floor is folded together / out in the same way in the upper and lower position.

Dividing the luggage compartment

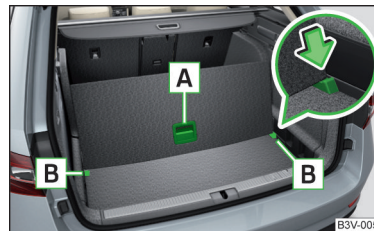

Fig. 162 Dividing the boot with variable loading floor

- › To **divide**, lift the variable loading floor by the handle **A** and push in the rear edge of the variable loading floor in the grooves **B** in the direction of the arrow » Fig. 162.

The variable loading floor is secured against movements in the grooves **B**.

Folding out takes place in reverse order.

The variable loading floor is divided in the same way in the upper and lower position.

Net partition

Using the net partition



B3V-0247

Fig. 163 Open part of the roll-up luggage compartment cover / release lever

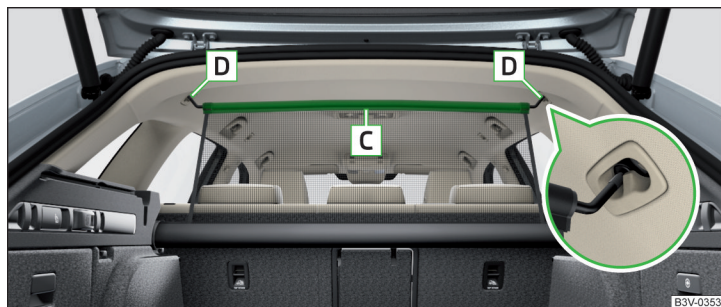

B3V-0353

Fig. 164 Correctly secure net partition behind the front seats in the pulled-out state

The net partition can either be pulled out and secured from behind the rear seats or behind the front seats.

Pull out and secure the net partition behind the rear seats

- › Fold out part **A** of the roll-up luggage compartment cover in the direction of arrow » Fig. 163.
- › Pull out the net partition at the crossbar **C**, insert in one of the mountings **D** and push forwards » Fig. 164.
- › Insert the crossbar on the other side of the vehicle in the mounting **D** in the same way.
- › Make sure that the crossbar is firmly seated in the two mountings **D**.
- › Fold back part **A** of the roll-up luggage compartment cover in the opposite direction of the arrow » Fig. 163.

Using the net partition behind the rear seats

- › Fold out part **A** of the roll-up luggage compartment cover in the direction of arrow » Fig. 163.
- › First pull the crossbar back slightly on the one side and then on the other side and remove it from the mountings **D** » Fig. 164.
- › **Hold** the crossbar **C** in such a way that the net partition can slowly roll up without being damaged.
- › Fold back part **A** of the roll-up luggage compartment cover in the opposite direction of the arrow » Fig. 163.

Pull out and secure the net partition behind the front seats

The process is analogous to that for behind the rear seats. Before removing the net partition, the rear seat backrests should be folded forwards. After rolling up the net partition in the housing, the rear seat backrests should then be folded back » page 87.

! CAUTION

If the net partition blocks when pulling it out, push the release lever **B** in the direction of the arrow » Fig. 163.

Removing and installing the net partition housing

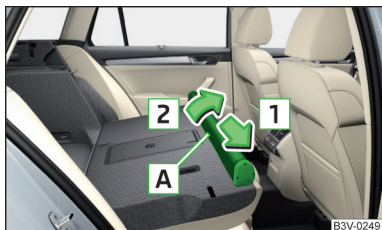

Fig. 165
Removing the net partition housing

- ▶ To **remove**, fold forward the rear seat backrests and open the rear right door.
- ▶ Push the housing **A** in the direction of the arrow **1** and remove it from the mountings in the direction of the arrow **2** » Fig. 165.
- ▶ To **install**, insert the recesses on the housing **A** into the mountings on the rear seat backrests and push the housing against the arrow **1** up to the stop.
- ▶ Fold the rear seat backrests to their original position.

Transportation on the roof rack

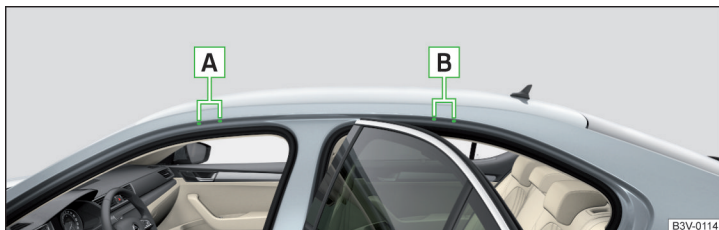

Fig. 166 Attachment points

Depending on the equipment, the roof bars can be attached at the attachment points » Fig. 166 or to the roof rail.

The attachment points **A** and **B** are located on both sides of the vehicle » Fig. 166.

Mounting and dismounting of the roof bars is carried out according to the instructions provided.

Roof load

The maximum permitted weight of the load incl. the carrier is 100 kg.

! WARNING

For road safety when transporting cargo on the roof rack, observe the following instructions.

- Always distribute the load on the roof rack evenly and secure properly using suitable lashing straps or tensioning straps.
- When transporting heavy objects or objects which take up a large area on the roof rack system, the handling of the car may change as a result of the displacement of the centre of gravity. The style of driving and speed must therefore be adapted to the current circumstances.
- The permissible roof load, permissible axle loads and permissible total vehicle weight must not be exceeded under any circumstances – risk of accident!

! CAUTION

- Make sure that the sliding / tilting roof or the boot lid does not collide with the roof load when opened.
- Ensure the roof aerial is not impaired by the load being transported.

1 Note

We recommend that you use a roof rack from ŠKODA Original Accessories.

Heating and ventilation

Heating, manual air conditioning system, Climatronic

Introduction

The heating heats and ventilates the vehicle interior. The air conditioning system also cools and dehumidifies the vehicle interior.

The heating effect is dependent upon the coolant temperature, thus full heat output only occurs when the engine has reached its operating temperature.

The cooling system works under the following conditions.

- ✓ The cooling system is switched on.
- ✓ The engine is running.
- ✓ The outside temperature is below 2 °C.
- ✓ The blower is switched on.

Fogging is prevented when the cooling system is switched on.

It is possible to boost the effectiveness of the cooling system by briefly activating the air recirculation system » [page 120](#).

Health protection

To reduce health risks (e.g. common colds), the following instructions for the use of the cooling system are to be observed.

- ▶ The difference between the indoor temperature and the outdoor air temperature should not be greater than about 5 °C.
- ▶ The cooling system should be turned off about 10 minutes before the end of the journey.
- ▶ Once a year, the air conditioning should be disinfected by a specialist garage.

! WARNING

- The blower should always be on to prevent the windows from misting. Otherwise there could be an accident.
- Under certain circumstances, air at a temperature of about 5 °C can flow out of the vents when the cooling system is switched on.

i Note

- The air inlet in front of the windscreen must be free of e.g. ice, snow or leaves to ensure that the heating and cooling system operates properly.
- After switching on the cooling **Condensation** from the evaporator of the air conditioning may drip down and form a puddle below the vehicle. This is not a leak!
- If the coolant temperature is too high, the cooling system is switched off to ensure that the engine cools down.

Heating and manual air conditioning



Fig. 167 Controls of the heating / air conditioning

Read and observe **i** on page 117 first.

Individual functions can be set or switched on by turning the dial or pressing the corresponding button » [Fig. 167](#).

- A** Setting temperature
 - ▶ | Reduce the temperature / Increase the temperature
- B** Set the blower speed (Level 0: Adjust the fan speed (level 0: fan off; level 6: highest speed))
- C** Set the direction of the air outlet » [page 121](#)
- D** Depending on equipment fitted:
 - ▶ Auxiliary heating and ventilation on / switch off » [page 122](#)
 - ▶ Switching the windscreen heater on/off » [page 77](#)
- A/C** Switch the cooling system on/off
- Switch on/off the rear window heating » [page 77](#)
- Switch recirculation on/off » [page 120](#)

When the function is switched on, the indicator lamp below the button lights up.

Information on the cooling system

After pressing the button **A/C**, the warning light underneath the button illuminates even if not all conditions are met for the cooling system. The cooling system starts to work as soon as the following conditions have been met » [page 117](#).

When the air distribution control is turned to position  the cooling system is activated.

i Note

To ensure adequate thermal comfort, during operation of the manual air conditioning there could be an increase in the engine idle speed in some circumstances.

Climatronic (automatic air conditioning)



Fig. 168 Front operating elements

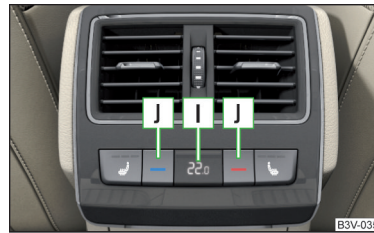





Fig. 169 Rear operating elements

 **Read and observe**  **on page 117 first.**

Individual functions can be set or switched on by turning the dial or pressing the corresponding button » [Fig. 168](#).

- A** Display the temperature setting for the left side
- B** Display the temperature setting for the right side
- C** Set the direction of the air outlet » [page 121](#)
- D** Adjust fan speed (the setting is indicated by the number of illuminated control lamps shown in the knob)
 - ▶ Turn to the left: Reduce speed up to turning off the Climatronic
 - ▶ Turn to the right: Increase speed
- E** Adjust the temperature for the left side (or for both sides)¹⁾
 - ▶ | Reduce the temperature / | Increase the temperature
- F** Adjust the temperature for the right side (or for both sides)²⁾
 - ▶ | Reduce the temperature / | Increase the temperature
- G** Depending on equipment fitted:
 - ▶  Auxiliary heating and ventilation on / switch off » [page 122](#)
 - ▶ **REST** Residual heat function on / off » [page 119](#)
- H** Interior temperature sensor
- I** Display of the temperature set in the rear » [Fig. 169](#)
- J** Set the rear temperature- deactivation/activation of the keys can be carried out by pressing the button **MENU** on the Climatronic → by tapping the function surfaces   on the Infotainment screen.
 - ▶ - Reduce the temperature / - Increase the temperature
-  Switch recirculation on/off » [page 120](#)

¹⁾ Applies to left-hand drive vehicles.

²⁾ Applies to right-hand drive vehicles.

MAX Intense air flow to the windscreen on / off (when switching on, the air flow to the windows and A/C is also switched on)

Switch on/off the rear window heating » page 77

Switching the windscreen heater on/off » page 77

MENU Setting Climatronic in Infotainment (can also be operated with some functions)

SYNC Synchronize the temperature inside the entire vehicle according to the temperature setting on the driver's side

AUTO Switching automatic mode on » page 120

A/C Switch the cooling system on/off

When the function is switched on, an indicator lamp lights up inside or below the button.

Setting temperature

The temperature can be set on the Climatronic control unit or in Infotainment» page 119. In the range between 16 °C to 29.5 °C, an automatic temperature control takes place.

At a temperature setting below 16 °C, **L0** lights up in the temperature display, the Climatronic functions with **maximum cooling performance**.

At a temperature setting over 29.5 °C, **H1** lights up in the temperature display, the Climatronic functions with **maximum heating output**.

Residual heat function REST

After switching off the ignition, the engine residual heat is used for heat retention in the vehicle interior. The function can only be switched on with the ignition off within 30 minutes after stopping the engine. The residual heat function turns off after about 30 minutes, or when the battery has a low charge state.

CAUTION

Do not cover the interior temperature sensor **H** » Fig. 168 - the function of the Climatronic could be affected.

Note

- In order to ensure adequate thermal comfort, there may be an increase in engine idle speed during operation of the Climatronic in some circumstances.
- The setting of the Climatronic is stored in the active user account personalisation » page 55.

Operate Climatronic in Infotainment

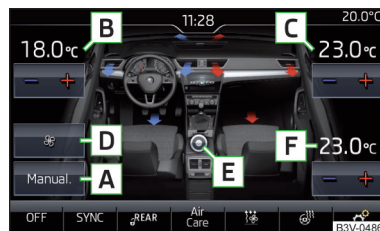

Fig. 170
Infotainment: example display of the main Climatronic menu

Read and observe on page 117 first.

► To display the **main menu** press the button **MENU** on the Climatronic control unit.

Function surfaces and screen display » Fig. 170

- A** Displays the current operation mode (or set the operation mode) of the Climatronic
- B** Set the desired temperature (front - left side)
- C** Set the desired temperature (front - right side)
- D** Setting the power in **AUTO** operation
- E** Switching on/off and adjusting the fan speed, cooling system, air distribution and air recirculation¹⁾
- F** Set the desired temperature (rear)
- Colour representation of the air flow from the air vents at the front (Blue colour - temperature reduction / red colour - temperature increase)
- OFF/ON** Switching on/off the Climatronic
- SYNC** Switch the temperature synchronisation on/off throughout the entire interior of the vehicle according to the temperature setting on the driver's side¹⁾
- Locking/unlocking of the temperature setting and heating of the rear seats using the rear buttons¹⁾
- Air Care** Switch Air Care function on/off
- Set the auxiliary heater and ventilation
- Switch the windscreen heating on/off¹⁾

 Turn the steering wheel heating on/off^{a)}

 Other Climatronic settings

^{a)} When function is switched on, the symbol in the function surface is green.

Other Climatronic settings

Press the **MENU** button on the Climatronic control panel → Tap the function surface  on the Infotainment screen.

- **Air con. profile** - Setting the operating performance **AUTO** during operation (applies to Infotainment Swing)
- **Automatic air recirculation** - Automatic re-circulated air mode on/off
- **Automatic auxiliary heater** - Quick interior heating on/off
- **Automatic windscreen heating** - Activates/deactivates the automatic windscreen heating

Climatronic - automatic operation

 **Read and observe**  on page 117 first.

The automatic mode is used in order to maintain a constant temperature and to demist the windows in the interior of the car.

- To **turn on**, press **AUTO** » Fig. 168 on page 118.
- To **turn off**, press any button for the air distribution or change the blower speed. The temperature regulation is continued.

Operating modes



Automatic mode works in three modes - moderate, medium, and intensive. Setting the different modes is carried out via the function surface  » Fig. 170 on page 119.

After the automatic mode is switched on, Climatronic works in the last selected mode. The currently selected mode is displayed in the Infotainment display.



Air distribution control

 **Read and observe**  on page 117 first.

The recirculation mode prevents contaminated outside air getting into the interior of the vehicle. In recirculated air mode air is sucked out of the interior of the vehicle and then fed back into the interior.

- To **switch on**, press the  button. The warning light below the button lights up.
- To **switch off**, press the  button again. The warning light below the button goes out.

Heating and manual air conditioning system

If the air distribution control is set to position  when the recirculation mode is switched on, the recirculated-air mode is switched off. By pressing the  button, the air recirculation also in this position can be switched on again.

When the cooling system (**A/C** button) is switched on and the temperature regulator is “turned” to the left, the recirculated-air mode is switched on.

Climatronic

The Climatronic can have a sensor that measures the air recirculation mode and automatically turns on if there is an increased concentration of pollutants in the incoming air.

When the pollutant concentration decreases to the normal level, the recirculated air mode is automatically switched off.

Automatic switch-on/switch-off of the air recirculation function can be set in the Infotainment screen, by pressing the **MENU** button on the Climatronic and by then pressing the function surface  → **Automatic air recirculation**.

A shut-off of the air recirculation function takes place automatically by pressing the **AUTO** button, possibly depending on the moisture conditions in the vehicle interior.

WARNING

The air recirculation cannot be switched on for a longer period of time because there is no supply of fresh air from the outside. “Stale air” may result in fatigue in the driver and occupants, reduce attention levels and also cause the windows to mist up. As soon as the windows mist up, turn the air recirculation mode off immediately - there is a risk of accident!

CAUTION

We recommend not smoking in the vehicle when the recirculating air operation is switched on. The smoke sucked from inside the vehicle is deposited on the evaporator of the air conditioner. This produces a permanent odour when the air conditioning system is operating which can only be eliminated through considerable effort and expense (replacement of compressor).

Climatronic - Air Care function



Fig. 171
Example display of the Air Care function

Read and observe **I** on page 117 first.

The Air CareFunction reduces pollutant penetration contained in the outside air into the vehicle.

When the function is activated, the air in the vehicle is circulated and cleaned at the same time. The cleaning process is displayed by the zones displayed in the Infotainment screen.

► To **switch on/off**, press the **MENU** button on the Climatronic control panel, and then tap on the function surface **Air Care** → **Active** on the Infotainment screen» Fig. 171.

To ensure correct Air Care functioning, all doors and windows including the panoramic sliding/tilting roof must be closed.

When opening a door or a window, the corresponding message is displayed in the Infotainment screen.

Air outlet vents

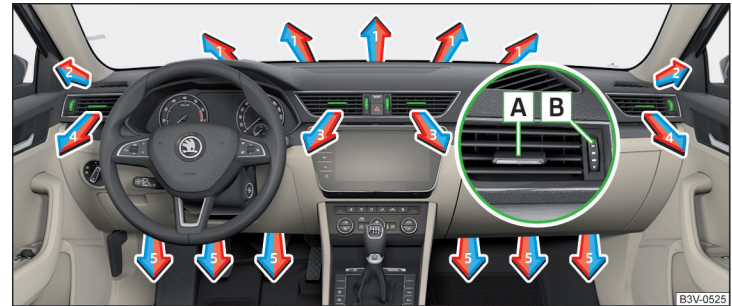

Fig. 172 Air vents at the front

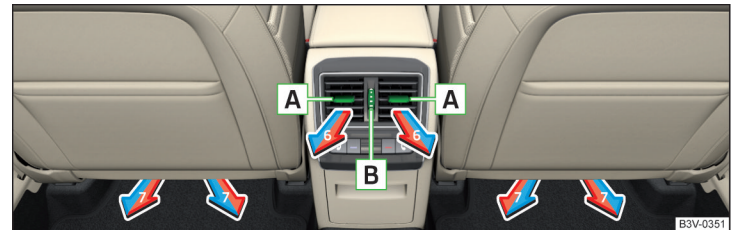

Fig. 173 Air vents at the rear

Read and observe **I** on page 117 first.





The direction of airflow can be adjusted using the air outlet vents **3, 4** » Fig. 172 and **6** » Fig. 173, and the vents can be opened and closed individually.

The setting of the airflow direction is carried out by moving the adjustment element **A** » Fig. 172 or » Fig. 173 in the desired direction.

► To **open**, turn the controller **B** » Fig. 172 or » Fig. 173 upwards.

► To **close**, turn the controller **B** » Fig. 172 or » Fig. 173 downwards.

Depending on the setting of the air distribution, the air stream comes out of the following air vents.

Set the direction of the air outlet	Air vents » Fig. 172 and » Fig. 173
	1, 2, 4
	1, 2, 4, 5, 7
	3, 4, 6
	4, 5, 7
	3, 4, 5, 6, 7

! CAUTION

Do not cover the air vents - the air distribution could be compromised.

Auxiliary heating (auxiliary heating and ventilation)

Introduction

The **auxiliary heating** heats the vehicle interior as well as the engine. For heating, fuel is consumed from the fuel tank.

The **auxiliary ventilation** enables fresh air to flow into the vehicle interior with the engine switched off, whereby the interior temperature is effectively decreased (e.g. with the vehicle parked in the sun).

The auxiliary heating (auxiliary heating and ventilation) (referred to just as auxiliary heating in the following) ensures the heating / ventilation depending on the setting of the air conditioning and the air outlet vents before switching off the ignition.

! WARNING

- The auxiliary heating must never be operated in closed rooms (e.g. garages) – risk of poisoning!
- The auxiliary heating must not be allowed to run during refuelling – risk of fire.
- The exhaust pipe of the auxiliary heating is located on the underside of the vehicle. If you want to use the auxiliary heating, do not park the car in places where the exhaust fumes can come into contact with flammable materials such as dry grass, undergrowth, leaves, spilled fuel etc. – risk of fire.

! CAUTION

The air inlet in front of the windscreen must be free (e.g. of ice, snow or leaves) to ensure that the auxiliary heating operates properly.

i Note

- The auxiliary heating switches the blower on, if it has achieved a coolant temperature of approx. 50 °C.
- In the engine compartment, water vapour may form during the operation of the heater.

Power on/off





Fig. 174 Button for switching on / off (Climatronic / manual air conditioning)

📖 Read and observe ! and ! on page 122 first.

Functional requirements of the auxiliary heating.

- ✓ The charge state of the vehicle battery is sufficient.
- ✓ The fuel supply is adequate (the warning light  is not illuminated in the instrument cluster).

Manual on / off

- ▶ Using the  button on the control panel of the air conditioner » Fig. 174.
- ▶ Using the  (switch on) / OFF (switch off) button on the remote control operation.

Automatic on / off

- ▶ Via an enabled pre-selection time in Infotainment.
- ▶ According to the environmental conditions.

After switching off the system, the coolant pump and the auxiliary heating will continue running a little while longer in order to burn the remaining fuel in the heating.

Setting automatic on / off

Climatronic: On the Climatronic, press the MENU button → tap the  function surface on the Infotainment screen. There will be a display of the last set operating mode with the option to change this.

Individually controlled air conditioning: In the Infotainment system, in menu  tap the  function surface.

Then follow the instructions in the Infotainment screen.

When automatic switching on is activated, the warning light in the  symbol button lights up for about 10 seconds after the ignition is turned off » Fig. 174.

Operation in Infotainment

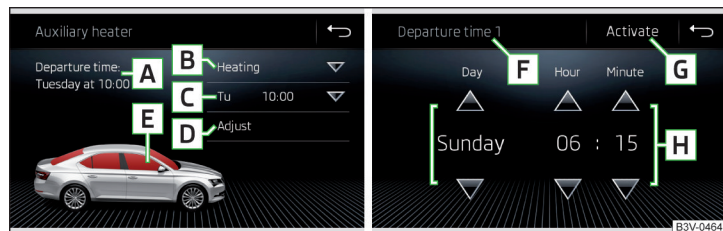



Fig. 175 Auxiliary heater: Main menu/set preset time

 Read and observe  and  on page 122 first.



Call up the main menu







➤ On the Climatronic, press the MENU button → Tap on the function surface  in the Infotainment screen.

Or vehicles with manual air conditioning:

➤ In the Infotainment system, in menu  tap the  function surface.

Function surfaces and screen display » Fig. 175

-  Departure time - Day and time when the vehicle is to be ready for use
-  Setting the operating mode (heating / ventilation)

-  List of pre-selected times, activation / deactivation of the preset time
-  Set the preset times 1-3 and the duration (10-60 minutes)
-  When heating the windows are shown in red / with continuous aeration, the windows are shown in blue
-  Currently displayed preset time
-  Activation of the currently displayed preset time
-  Setting the departure time: Day, hour, minute

Only one preset time can be active. The activated preset time will be deactivated again after it has started automatically. For the next start, activate one of the preset times.

i Note

- When selecting the day in the preset time, there is an option between Sunday and Monday without the specified day. If this setting is selected, the vehicle will be ready for use at the selected time, regardless of the current day.
- If a different time is set, the activated preset time is automatically deactivated. The preset time must be reactivated.

Radio remote control

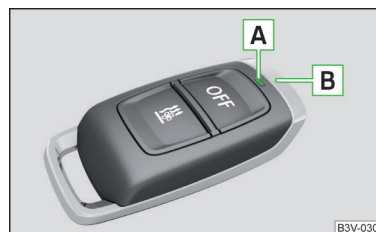





Fig. 176
Radio remote control

 Read and observe  and  on page 122 first.

Description of the remote control » Fig. 176

-  Warning light
-  Aerial
-  Switch on the auxiliary heating
- OFF** Switch off the auxiliary heating

The auxiliary heating is switched on/off by pressing the button. To switch the remote control on or off, hold the remote control vertically, with the aerial **B** » Fig. 176 pointing upwards. Do not cover the antenna with the fingers or the palm of the hand.

Display warning light A	Meaning
Lights up green for 2 seconds.	The auxiliary heating has been switched on.
Lights up red for 2 seconds.	The auxiliary heating has been switched off.
Slowly flashes green for 2 seconds.	The ignition signal was not received.
Quickly flashes green for 2 seconds.	The auxiliary heating is blocked, e.g. because the tank is nearly empty or there is a fault in the auxiliary heating.
Flashes red for 2 seconds.	The switch off signal was not received.
Lights up orange for 2 seconds, then green or red.	The battery is weak, however the switching on or off signal was received.
Lights up orange for 2 seconds, then flashes green or red.	The battery is weak, however the switching on or off signal was not received.
Flashes orange for 5 seconds.	The battery is discharged, however the switching on or off signal was not received.

Replace the battery » page 292.

! CAUTION

- The remote control must be protected against moisture, severe shocks and direct sunlight - otherwise, there is a risk of damage to the remote control.
- The range of the remote control with a charged battery is a few hundred metres (depending on obstructions between the remote control and the vehicle, weather conditions, the battery condition etc.).

Infotainment

Introductory information

Important information

Introduction to the subject

! WARNING

- Only use Infotainment in such a way that you have control of the vehicle in every traffic situation (e.g. Do not write text messages while driving, do not couple or connect the telephone, do not work with the contact list, do not enter any destinations, do not connect WLAN or SmartLink etc.)- Otherwise there is a risk of an accident!
- Always route the connection cable of the external device in such a way that it does not restrict you when driving.

! WARNING

- Adjust the volume to ensure that acoustic signals from outside the vehicle, e.g. sirens from emergency vehicles, can be heard at all times.
- High volumes can cause hearing damage!

! CAUTION

In some countries, some Infotainment features can no longer be selected when the vehicle is running faster than a certain speed. This is not a malfunction, but complies with the national legal regulations.

Mobile devices and applications



BIT-0612

Fig. 177
QR code with reference to web pages for checking the compatibility of devices

The availability of some of the functions described in this Owner's Manual depends on the type of device to be connected and the applications installed in it.

Compatibility

On the ŠKODA pages, check to see if Infotainment is compatible with the selected mobile devices. This check takes place by reading the QR code » Fig. 177 or after typing the following address into the web browser.

<http://go.skoda.eu/compatibility>

Applications

Applications can be installed in external devices (e.g. Mobile, tablet) making it possible to display additional information in the Infotainment screen or to operate Infotainment.

Due to the variety of applications as well as their ongoing development, the available applications may not work in all external devices. ŠKODA AUTO can accept no liability for their proper function.

The range of available applications and their functionality is dependent on the Infotainment type, as well as vehicle and region.

Infotainment Overview

Description - Infotainment Columbus



BIT-0812

Fig. 178 Infotainment Columbus

⏻ Switches Infotainment on/off

- 1 **MENU** Overview of Infotainment menu » [page 131](#)
 - 2 **HOME** - Display of the main screen "HOME" » [page 132](#)
- ⏮ Volume up
- ⏭ Volume down
- 3 Touch screen » [page 127](#)

Description - Infotainment Amundsen



Fig. 179 Infotainment Amundsen

- ⏻ Left control dial for switching Infotainment on and off; volume adjustment
- ⦿ Control dial for calls and confirmations
- 1 **RADIO** - Radio menu » [page 147](#)
 - 2 **MEDIA** - Media menu » [page 150](#)
 - 3 **PHONE** - Telephone menu » [page 161](#)
 - 4 **VOICE** - Voice control » [page 133](#)
 - 5 **NAV** - Navigation menu » [page 180](#)
 - 6 **APP** - SmartLink menu » [page 175](#)
 - 7 **CAR** - Vehicle system settings » [page 202](#)
 - 8 **MENU** Overview of Infotainment menu » [page 131](#)
 - 9 Touch screen » [page 127](#)

Description - Infotainment Bolero



Fig. 180 Infotainment Bolero

- ⏻ Left control dial for switching Infotainment on and off; volume adjustment
- ⦿ Control dial for calls and confirmations
- 1 **RADIO** - Radio menu » [page 147](#)
 - 2 **MEDIA** - Media menu » [page 150](#)
 - 3 **PHONE** - Telephone menu » [page 161](#)
 - 4 **VOICE** - Voice control » [page 133](#)
 - 5 **SETUP** - Infotainment settings » [page 136](#)
 - 6 **APP** - SmartLink menu » [page 175](#)
 - 7 **CAR** - Vehicle system settings » [page 202](#)
 - 8 **MENU** Overview of Infotainment menu » [page 131](#)
 - 9 Touch screen » [page 127](#)

Description – Infotainment Swing

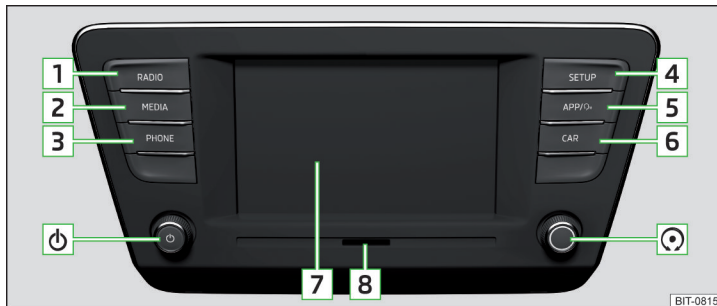

Fig. 181 Infotainment Swing

- ⏻ Left control dial for switching Infotainment on and off; volume adjustment
- ☎ Control dial for calls and confirmations
- 1 **RADIO** - Radio menu » page 147
- 2 **MEDIA** - Media menu » page 150
- 3 **PHONE** - Telephone menu » page 161
- 4 **SETUP** - Infotainment settings » page 144
- 5 Depending on equipment fitted:
 - ▶ **APP/☎** - Menu SmartLink (Press) / turn on / off the voice control function SmartLink (hold) » page 175
 - ▶ **SOUND** - Sound settings » page 144
- 6 **CAR** - Vehicle system settings » page 202
- 7 Touch screen » page 127
- 8 SD card slot » page 153

External module

applies to Infotainment Amundsen and Columbus.

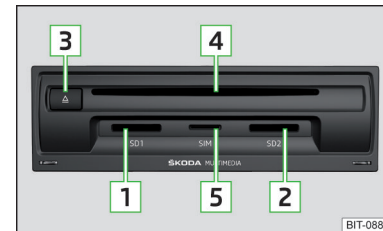

Fig. 182
Example of an external module

Depending on the vehicle configuration and Infotainment type, all the following elements must not be included in the external module.

The external module is located in the storage compartment on the front passenger side » Fig. 182.

- 1 SD1 card slot
- 2 SD2 card slot
- 3 - CD / DVD eject button
- 4 CD / DVD slot
- 5 SIM card slot

Touch screen

The Infotainment can be operated by **lightly touching the screen with your fingers**.

The brightness level of the screen can be set by » page 136 or » page 144.

To protect the screen, a suitable protective film for touch screens can be used.

The screen can be cleaned with a soft cloth and pure spirit if necessary.

Infotainment operation

Infotainment operation

Screen areas



Fig. 183
Screen areas

Description of the display » Fig. 183

- A** Status line with time and outdoor temperature data and other information
- B** Information and the operation of the current menu
- C** Function surfaces of the current menu

Operation principles

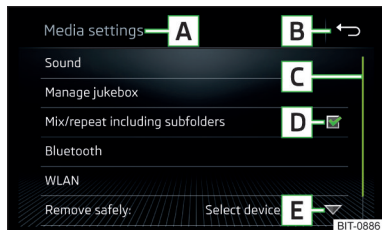

Fig. 184
Screen display

Description of the display » Fig. 184

- A** Identification of the current menu
- B** Return to the higher-level menu
- C** Scroll symbol – moving in the menu is possible by moving fingers up or down on the scroll symbol

- D** Menu item with “Checkbox”
 - ▶ - Function is switched on
 - ▶ - Function is switched off
- E** ▼ Opens a sub-menu of the menu item with a “pop-up window”

Function surfaces

The screen areas which confirm a function or a menu are called “**function surfaces**”.

- ▶ **White text** - the surface is active and thus selectable
- ▶ **Grey text** - the surface is inactive and thus not selectable
- ▶ **Green frame** - currently selected surface

Selecting menu/menu item/function

- ▶ Drag your finger over the screen in the required direction.
- ▶ By moving your finger over the slider
- ▶ Turning the knob (◂) (not applicable to Infotainment Columbus).

Confirming menu/menu item/function

- ▶ By tapping on the function surface.
- ▶ Press the wheel (◂) (not applicable to Infotainment Columbus).

Returning to higher-level menu

- ▶ By tapping on the function surface ◂.
- ▶ By tapping on the screen outside of the “pop-up window”.
- ▶ By pressing the corresponding button next to the screen (e.g. in the *Media* menu, by pressing the sensor field/the **MEDIA** button) (not applicable to Infotainment Columbus).

Select the menu item / function value

- ▶ ◂ - Selected menu item/function value
- ▶ ○ - Deselected menu item/function value

Set value

- ▶ By tapping on the function surface ◂ or ▸ the bottom of the screen.
- ▶ By touching or moving your finger over the scale.
- ▶ Turning the knob (◂) (not applicable to Infotainment Columbus).

i Note

Depending on the equipment, the Infotainment can also be operated by means of the buttons on the multifunction steering wheel. Further information » [page 51](#).

Operating the menus

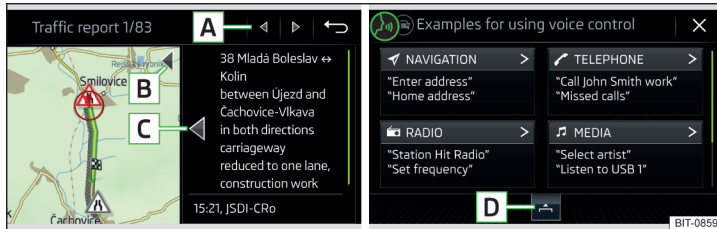

Fig. 185 Operating the menus

Operating the menus » Fig. 185

- A** Browse the menu- List entries
- B** Enlargement/reduction of the menu window (applies to the infotainment Columbus)
- C** Expand/reduce the menu window (applies to Infotainment Amundsen)
- D** Open / close the menu window
- X** Close the menu window

Alphanumeric with keyboard



Fig. 186
Example of the keyboard display

The alphanumeric keypad is used to enter for letters, numbers and characters.

Description of the alphanumeric keyboard » Fig. 186

- A** Input line
- B** Context-dependent:
 - ▶ \uparrow/\downarrow - Toggle upper case to lower case and vice versa
 - ▶ $\$@\#$ - Switch to special characters
 - ▶ **123** - Switch to numbers
- C** Context-dependent:
 - ▶ **123** - Switch to numbers
 - ▶ **ABC** - Switch to Latin letters
 - ▶ **ABB** - Switch to Cyrillic letters
- $\cdot\equiv$ - Display of visited entries (the number of visited entries is displayed in the function surface)
- \otimes Erase the entered characters
- \triangleleft By holding the variants of each type are displayed.
- $\text{globe} / \text{globe}$ Switch between keyboards with specific characters of the selected languages » [page 137](#) or » [page 144](#)
- $_$ Enters a blank
- \leftarrow Move the cursor within the input line to the left
- \rightarrow Move the cursor within the input line to the right
- OK** Confirmation of the entered number

Search

While entering characters, a search is made for corresponding entries.

The entry such as a telephone contact to be searched for must be entered along with the special characters (diacritics).

By tapping on the function surface $\cdot\equiv$ a list of matching entries opens.

Gesture control

Only valid for Infotainment Columbus.





Fig. 187
Example of a menu with
gesture control

Some menus of Infotainment Columbus can be operated by means of hand gestures by slowly moving the hand back and forth approximately 8 cm above the Infotainment screen.

The menus with gesture control feature the symbol  in the lower right-hand corner » Fig. 187.



Switching the function on / off

The gesture control function is switched on at the factory.

► To **switch the function on/off**, tap the sensor field  and then the function surface  → Screen → Hand gesture .



Acoustic confirmation of gesture

When the function is switched on, Infotainment indicates that a gesture has been recognised by means of an acoustic signal.

► To **activate/deactivate** the acoustic confirmation of a recognised gesture, tap the sensor field  and then the function surface  → Screen → Audible hand gesture feedback.



Visual confirmation of the gesture

When the function is switched on and a gesture has been recognised, Infotainment shows an animation with the bottom bar moving in the direction of the hand movement.

► To **activate/deactivate** the visual confirmation of a recognised gesture, tap the sensor field  and then the function surface  → Screen → Visual hand gesture feedback.

Switching Infotainment on/off

Only valid for Infotainment Columbus.

- To **switch on** Infotainment, press .
- To **switch off** Infotainment, hold .

Applies to Infotainment Amundsen, Bolero, Swing

- To **power on/off** Infotainment, press .

Automatic switch-on of Infotainment

If Infotainment was not turned off with  before the ignition was turned off, it will automatically switch on when the ignition is switched on.

Automatic switch-off of Infotainment

If the vehicle key is pulled out of the ignition lock while Infotainment is switched on, Infotainment will switch off automatically.

If the vehicle is fitted with the starter button, Infotainment will switch off automatically after the engine is switched off and the door is opened.

With the ignition off, Infotainment will automatically turn off after about 30 minutes.

Infotainment turns off automatically under certain circumstances. Infotainment informs of this via a text message on the Infotainment screen.

Restart Infotainment



If Infotainment does not respond (if it “freezes”) This can be restarted by holding  for longer than 10 s.

Show time and date on the screen

Standby mode

With the ignition off and infotainment (standbyMode), it is possible to display the time and date in the Infotainment screen.

Applies to Infotainment Columbus, Amundsen, Bolero

- To switch the time and date display on/off, press the  sensor field and then tap the function surface  → Screen Show clock in standby mode.

The display mode can be changed by finger motion across the screen sideways.

Applies to Infotainment Swing

- To switch the time and date display on/off, press the  button, then tap the function surface Screen → Show clock in standby mode.

"Screen off" mode



With the ignition on and functions **Switch off screen (in 10 seconds)** and **Display clock when screen is off** » [page 136](#) enabled, it is possible to display the time and date when the Infotainment screen is switched off.

The display type depends on the display mode selected in standby mode (does not apply to the Infotainment Swing).



Adjusting the volume

Every change in volume is displayed on the screen.

Only valid for Infotainment Columbus.

- To **increase the volume**, tap the function surface .
- To **decrease the volume**, tap the function surface .
- To **activate/deactivate the mute setting**, tap the sensor field .

Applies to Infotainment Amundsen, Bolero, Swing

- To **increase the volume**, turn the controller  clockwise.
- To **reduce volume**, turn the controller  anticlockwise.
- To **mute**, turn the controller  to the left to 0.

The following symbol appears in the display when the sound is muted .

If, at the time of muting, sound is being played from a source in the *Media* menu, then the playback is stopped.



! CAUTION

- High volumes can cause sound resonance in the vehicle.
- When changing or connecting an audio source, this may cause sudden changes in volume. Reduce the volume before changing or connecting an audio source.

Electronic voice amplification for driver and passenger

Applies to Infotainment Columbus, Amundsen, Bolero.

The voice enhancer allows transmission of the driver's and passenger's voice on the speakers in the rear.

- To set the voice amplification volume, tap the  sensor field and then tap the function surface  → **Volume** → **Voice Enhancer**.
- **or:** While setting the volume, tap the function surface .

Infotainment menus

Applies to Infotainment Columbus, Amundsen, Bolero.



Fig. 188
Overview of Infotainment menu: Grid display

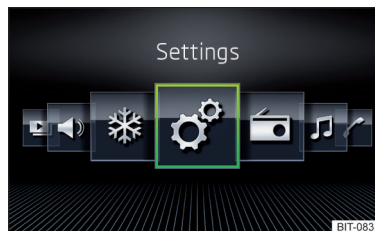













Fig. 189
Overview of Infotainment menu: List

- To **display the overview of Infotainment menus**, press the  sensor field.
- To **set the display mode**, press the button  sensor field and then tap the function surface  → **Screen** → **Menu**.
- Select the **Grid display** » [Fig. 188](#) or **Horizont. Display** » [Fig. 189](#) option.

Overview of Infotainment menus

-  **Radio menu** » [page 147](#)
-  **Media menu** » [page 150](#)
-  **"ŠKODA Connect" Online Services** » [page 13](#)
-  **SmartLink menu** » [page 175](#)
With a connection established to an external device,  the actual connection is shown instead of a symbol
 - ▶  **Android Auto** » [page 176](#)
 - ▶  **Apple CarPlay** » [page 177](#)
 - ▶  **MirrorLink®** » [page 178](#)
-  **Telephone menu** » [page 161](#)

- 🚗 Vehicle system settings » [page 202](#)
- 📍 Navigation menu » [page 180](#) (Applies to Infotainment Columbus, Amundsen)
- 📄 List of traffic reports (TMC) (applies to Infotainment Columbus, Amundsen) » [page 200](#)
- 📻 Media Command menu (applies to Infotainment Columbus, Amundsen) » [page 159](#)
- 🖼️ Images menu » [page 156](#)
- 🔊 - Sound settings » [page 136](#)
- ❄️ Air conditioning menu » [page 119](#)
- ⚙️ Infotainment settings » [page 136](#)

Main screen “HOME”

Only valid for Infotainment Columbus.



Fig. 190
HOME main screen

- To display the information, tap the **HOME** sensor field.

The “HOME” main screen contains three windows.

In the left window » [Fig. 190](#) the navigation map is always displayed. By tapping the screen within this window, the *Navigation* main menu is displayed.

The contents of the window to the right can be changed. By holding the function surface **A**, the list of selectable menus is displayed.

By tapping the function surface **A** or by double-finger tapping on the screen within each window, the appropriate main menu is displayed.

If there are other pages in the window, then the associated symbols are displayed in area **B**. By moving your finger across the screen within each window, it is possible to display these pages.

Configuration wizard

The Configuration wizard is **automatically displayed** if there are at least two non-selected menu items after turning on Infotainment, or if a new user account in personalisation is selected.

- For **manual display** in Infotainment Columbus, Amundsen and Bolero, tap the **MENU** sensor field and then tap on the function surface **☞** → **Configuration wizard**.
- For **manual display** in Infotainment Swing, press the **SETUP** button, then tap the function surface **Configuration wizard**.

The Configuration wizard allows you to set the following menu items in sequence.

- 👤 Identification of the personalisation user account » [page 55](#)
- 🕒 Time and date format
- 📶 Storing the radio station with the strongest reception signal at present
- 📞 Pairing and connecting a telephone to Infotainment
- 🏠 Home Address provided (valid for Infotainment Columbus, Amundsen)
- 🔒 Setting “ŠKODA Connect” online services

The selected menu item is marked with the ✓ symbol.

Operating using an application in the external device

Some Infotainment functions can be operated using an application in the supported external device.

For the complete functionality of the application, data transmission from external devices must be activated and, if necessary, operation of the Infotainment via the application must be approved.

Applies to Infotainment Columbus, Amundsen, Bolero

- Activate data transfer in Infotainment. To do so, tap the **MENU** sensor field and then the function surface **☞** → **Mobile device data transfer** → **Activate data transfer for ŠKODA Apps**.
- Release Infotainment operation using the application. To do so, tap the **MENU** sensor field and then the function surface **☞** Tap → **Mobile device data transfer** → **Operation via apps**: → **Confirm/Allow**.
- Connect Infotainment to an external device via WLAN » [page 173](#).
- In the external device, launch an application for Infotainment operation (e.g. ŠKODA Media Command).

Applies to Infotainment Swing

➤ Activate data transfer in Infotainment. Press the **SETUP** button and then tap on the function surface **Activate data transfer for ŠKODA apps**.

i Note

The description of Infotainment operation ŠKODA Media Command is part of the application.

Voice control

Introduction to the subject

Applies to Infotainment Columbus, Amundsen, Bolero.

The navigation, telephone, radio and media menu can be operated by voice commands.

The voice control system can be used either by the driver or by the front passenger.

Function requirements for voice control

- ✓ Infotainment is switched on.
- ✓ There will be no telephone call using a telephone connected to Infotainment.
- ✓ The parking aid is not active.

Requirements for optimum voice command recognition

- ▶ The voice commands must only be issued when the **VOICE** symbol is displayed on the Infotainment screen and the input tone has completely faded.
- ▶ Speak at your normal volume without intonation and long breaks.
- ▶ Avoid poor pronunciation.
- ▶ Close the doors and window in order to avoid disturbing environmental influences on the function of the voice control.
- ▶ You are recommended to speak louder at higher speeds, so that the sound of your voice is not drowned out by the increased ambient noise.
- ▶ During voice control, limit additional noise in the vehicle, e.g. passengers talking at the same time.

! WARNING

The emergency number should be dialled manually. Your voice commands may not be recognized in such situations. The telephone connection may not be established or the connection may take too much time to complete.

! CAUTION

- The messages are generated by Infotainment. The flawless clarity (e.g. road or city name) cannot always be guaranteed.
- For some Infotainment languages, there is no voice control available. Infotainment indicates this fact through a text message that is displayed after setting the device language screen.

i Note

During voice control, no nav. announcements and traffic announcements are played.

Voice control on / off



Fig. 191

Voice control: Main menu

Activating

➤ Press the button **VOICE** on the multifunction steering wheel **or** the **VOICE** sensor field on the Infotainment (does not apply to Infotainment Columbus).

The **main menu** is displayed » Fig. 191.

Switching off

➤ Press the button twice **VOICE** on the multifunction steering wheel **or** the **VOICE** sensor field on the Infotainment twice (does not apply to Infotainment Columbus).

➤ **or:** Issue the voice command "**End voice control**".

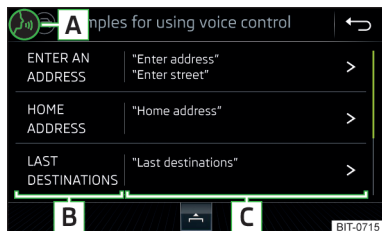

Fig. 192
Example of screen display

In the voice control main menu » Fig. 191 on page 133 There are basic voice commands for the individual menus.

Other voice commands are displayed by tapping the respective functional area or issuing the name of the respective command (e.g. Navigation). The screen shows the following » Fig. 192.

A Context-dependent:

- ▶ The system is waiting for a voice command
- ▶ The system recognises a voice command
- ▶ The system plays a message
- ▶ Voice command entry was stopped

B Available list entries

C Possible voice commands

- > Display other possible voice commands

Voice commands that can be issued, are indicated in "quotation marks".

i Note

The display of the voice control symbols **A** » Fig. 192 are dependent of the equipment fitted also on the display of the instrument cluster.

Enter

The voice command must only be issued when the symbol is displayed in the Infotainment screen and the input tone has completely faded. The input tone can be switched on / off. To do so, tap the **MENU** sensor field and then the function surface → **Voice control**.

It is not necessary to wait for the end of message playback when Infotainment is playing a message. The Infotainment message can be acknowledged by tapping the **VOICE** sensor field (does not apply to Infotainment Columbus) or pressing the button on the multifunction steering wheel. Then a voice command can be issued. The voice control is hereby much faster.

Stop

This allows for more time for input of the voice command (e.g. in the list of visited contacts).

The process for the voice command input can be stopped by moving a finger up/down across the screen or by turning the controller (not applicable to Infotainment Columbus).

When stopping, the symbol changes from .

Restore

The procedure for voice command input can be restarted in one of the following ways.

- ▶ By tapping on the function surface .
- ▶ By tapping the **VOICE** sensor field on the Infotainment (does not apply to Infotainment Columbus).
- ▶ By pressing the key on the multifunction steering wheel.

Not recognising a voice command

If a voice command is not detected three times in succession by Infotainment, then the voice control is stopped.

Correction of a voice command input

A voice command can be corrected, modified or re-entered by tapping the **VOICE** sensor field (does not apply to Infotainment Columbus) or pressing the button on the multifunction steering wheel. However, this is only possible as long as the symbol appears on the screen.

You do not have to wait until the voice command is recognised by Infotainment.

Voice commands can be used during voice control

Voice command	Operation
“Back”	Return to the previous menu
“Help”	reproducing and displaying possible voice commands

Voice commands that can be used while browsing the list entries

Voice command	Operation
“Next page”	Browse menu / list / directory
“Previous page”	
“First page”	
“Last page”	

Additional Information

Navigation - applies to Infotainment Columbus

If the set Infotainment language matches the language of currently selected country when entering the destination, then the destination address can be entered in **one step**.

The voice command “**Navigate**” can be issued and straight away, the city, street and street number (if it is included in the navigation data) Interest (POI) or a contact with the previously stored address.

Navigation - applies to Infotainment Amundsen

To the destination, you are first required to issue the command “**enter address**” and then follow Infotainment instructions.

It is not necessary to spell city and street names if the entered destination is located in a country that has no voice control available for the language.

Online POI search – applies to Infotainment Columbus, Amundsen

When “Infotainment Online” » [page 18](#) services are activated, a POI search can also be carried out online by issuing the voice command “**Find online POI**”.

Radio

In order for a radio station can be selected using voice command, the station must be stored in the list of available stations » [page 148](#) or in the preset list » [page 148](#).

Updating the Infotainment software



Fig. 193
Available software updates on the ŠKODA websites

The software update ensures optimum operation of Infotainment (e.g. Compatibility with new telephones).

Information on Infotainment compatibility can be found on the following ŠKODA Internet pages. This takes place by reading the QR code » [Fig. 193](#) or after typing the following address into the web browser.

<http://go.skoda.eu/updateportal>

Applies to Infotainment Columbus, Amundsen, Bolero

- ▶ To **determine the software version**, tap the **MENU** sensor field and then the function surface → **System information**.
- ▶ To **start the software update**, tap the **MENU** sensor field and then tap the function surface → **System information** → **Update software**.

Applies to Infotainment Swing

- ▶ To **determine the software version**, press the **SETUP** button, then tap on the **system information** function surface.
- ▶ To **start the software update**, press the **SETUP** button, then tap on the **system information** → **update software** function surface.

Infotainment settings - Columbus, Amundsen, Bolero

Infotainment system settings

sound settings

- ▶ Tap the **MENU** sensor field and then the function surface .
- **Volume** - Volume settings
 - **Radio announcements** - Volume adjustment of traffic announcements (TP)
 - **Navigation announcements** - Volume adjustment of navigation announcements (does not apply to infotainment Bolero)
 - **Voice control** - volume setting for voice output
 - **Maximum switch-on volume** - Setting the maximum volume when switching on Infotainment
 - **Speed-dependent Volume adjustment** - Increases the volume as speed increases
 - **Bluetooth audio**: - Volume setting of the device connected via Bluetooth [®] audio profile
 - **Quiet** - Low volume
 - **Medium** - Medium volume
 - **Loud** - High volume
 - **Entertainment fading while parking** - Lowers the audio volume (e.g. radio volume) when the parking aid is activated
 - **Entertainment fading (nav. announcements)** - Lowers the audio volume (e.g. radio volume) in the event of a navigation announcement
- **Voice Enhancer** - Volume adjustment of voice amplification for driver and front passenger to the speakers in the rear
- **Bass - Mid - Treble** - Setting the equalizer
- **Balance - Fader** - Sets the balance between left and right, front and rear
- **CANTON Equaliser** - Setting the equalizer
 - **Individual**- Adjustment of treble, mid and bass
 - **Profile** - Setting of the profile (e.g. **Rock**, **Classical** and so on.)
- **CANTON Optimisation** -Setting the optimum room sound perception
 - **All areas** - Setting optimised for the whole vehicle interior
 - **Front** - Optimised setting for the front seats
 - **Driver** - Optimised setting for the driver
- **CANTON surround** - Setting the surround sound levels (“-9 "Stereo / “+9"full surround)
- **Subwoofer** - Subwoofer volume settings

- **Sound focus** -Setting the optimum room sound perception
 - **All areas** - Setting optimised for the whole vehicle interior
 - **Driver** - Optimised setting for the driver
- **Touchscreen tone** - Switch on/off audible tone when touching the screen
- **No navigation sound during call** - Switching on / off the nav. announcements during a telephone conversation (does not apply to Infotainment Bolero)

Screen settings

- ▶ Tap the **MENU** sensor field and then the function surface  Tap → **Screen**.
- **Menu**: Setting the Infotainment menu display
 - **Horizont. Display** - Horizontal display » [Fig. 189 on page 131](#)
 - **Grid display** - Grid display » [Fig. 188 on page 131](#)
- **Switch off screen (in 10 seconds)** - Enable/disable the automatic power off function
- **Display clock when screen is off** - Time and date display when the screen is switched off
- **Brightness**: - Adjusts the brightness of the screen
- **Touchscreen tone** - Switch on/off audible tone when touching the screen
- **Menu button tone** - Turn on / off the acoustic signal by pressing a button next to the screen
- **Hand gesture** - Enable/disable the gesture control using hand movements via the Infotainment screen (applies to Infotainment Columbus)
- **Visual hand gesture feedback** - Enable/disable the animation when a gesture is recognised (applies to Infotainment Columbus)
- **Audible hand gesture feedback** - Enable/disable acoustic signal when a gesture is recognised (applies to Infotainment Columbus)
- **Animation when finger near screen** - Turn the proximity sensors on/off (When the function is on, e.g. *Navigation* will be shown in the main menu when moving a finger towards the bottom bar with the functional surfaces on the screen)
- **Show clock in standby mode** - Time and date displayed on the screen when the ignition is switched on and Infotainment is switched off

Time and date settings

- ▶ Tap the **MENU** sensor field and then the function surface  → **Time and date**.
- **Clock time source**: - Setting the time source: manual/GPS (applies to Infotainment Columbus, Amundsen)
- **Time**: - Time settings
- **Summer (DST)** - Switches summer time on/off

- **Automatic summer time** - Switches the automatic switch to summer time on/off
- **Time zone:** - Select the time zone
- **Time format:** - Set the time format
- **Date:** - Date settings
- **Date format:** - Set the date format

Setting the Infotainment language

- Tap the **MENU** sensor field and then the function surface  → **Language**.
- Select the Infotainment language.

In some languages, after selecting the function surface **Female** and **Male** are displayed for the choice of voice prompts for Infotainment.

i Note

- When a language is selected which does not support voice control, Infotainment will indicate with a message on the screen.
- The messages are generated by Infotainment. Flawless clarity (e.g. road or city name) cannot always be guaranteed.

Additional keypad language settings

- Tap the **MENU** sensor field and then the function surface  → **Additional keypad languages**.

In this menu, a keyboard language set can be added to allow characters other than those in the currently selected language to be entered.

Unit settings

- Tap the **MENU** sensor field and then the function surface  Tap on → **Units** .
- **Distance:** - Distance units
- **Speed:** - Speed units
- **Temperature:** - Temperature units
- **Volume:** - Volume units
- **Fuel consumption:** - Consumption units
- **Pressure:** - Pressure units for tyre pressure

Settings for data transfer

Activated data transfer enables data transfer between the Infotainment system and the external device or the operation of some Infotainment functions using the applications of the external device (e.g. ŠKODA Media Command).

- Tap the **MENU** sensor field and then the function surface  → **Mobile device data transfer**.

- **Activate data transfer for ŠKODA apps-** Turning data transfer on and off
- **Use apps to operate:** - Setting Infotainment operation via the applications of the external device (applies to Infotainment Columbus, Amundsen)
 - **Deactivate** - Deactivate Infotainment operation via an external device
 - **Confirm** - Infotainment operation with required confirmation
 - **Allow** - Infotainment operation without required confirmation

Voice control settings

- Tap the **MENU** sensor field and then the function surface  → **Voice control**.

- **Example commands (Infotainment system)** - Turn on/off display of the menu containing voice commands in the Infotainment screen when voice control is activated
- **Example commands (instrument cluster)** - Turn on/off display of the menu containing basic voice commands when voice control is activated
- **Voice control session start tone** - Switch on/off the audible signal when turning on the voice control
- **Voice control session end tone** - Switch on/off the audible signal when voice control ends
- **Input tone in voice dialogue** - Switch on/off the audible signal for the voice input
- **End tone in voice dialogue** - Switch on/off the audible after the voice input

Safe removal of the external device

- Tap the **MENU** sensor field and then the function surface  **Remove safely:** and select the external device to be removed.

Reset to factory settings

- Tap the **MENU** sensor field and then the function surface  → **Factory settings**.



In this menu, all or only chosen settings can be restored.

Bluetooth® Settings

- › Tap the **[MENU]** sensor field and then the function surface  → **Bluetooth**.
- **Bluetooth** - Switch on/off Bluetooth® function
- **Visibility**: Switch the visibility of the Bluetooth® device for other Bluetooth® devices on/off
- **Name**: - Changing the name of the Bluetooth® device
- **Paired devices** - Display the list of coupled Bluetooth® devices
- **Find devices** - Searches for available Bluetooth® devices
- **Bluetooth audio (A2DP/AVRCP)** - Turn on/off the ability to connect a Bluetooth® audio device (e.g. MP3 player, tablet etc...)

Wireless settings

Applies to Infotainment Columbus, Amundsen.

- › Tap the **[MENU]** sensor field and then the function surface  → **WLAN**.
- **WLAN** - List of available hotspots of external devices
 - **WLAN** - Turn on / off Infotainment wireless
 - **WPS Quick Connect (WPS button)** - Establishing a secure connection to the hotspot of the external device using WPS (applies to Infotainment Amundsen)
 - **Manual settings** - Setting the parameters for search and connection to the hotspot of the external device
 - **Network name** - Enter the Hotspot name
 - **Network key** - Setting the access password
 - **Security level**: Security setting (WPA2 always set)
 - **Connect** - Connection establishment
 - **Find** - Search / Restore the list of available hotspots
- **Mobile hotspot** - Setting Infotainment hotspot (in the functional surface the symbol is  displayed with the number of connected external devices)
 - **Mobile hotspot** - Turn on / off Infotainment hotspot
 - **WPS quick connection (WPS button)** - Establishing a secure connection to the Infotainment hotspot via WPS (applies to Amundsen)
 - **Hotspot (WLAN) settings** - Setting the parameters for the connection to Infotainment hotspot
 - **Security level**: Security setting (WPA2 always set)
 - **Network key** - Input of the access password
 - **SSID: ...** - Name of the infotainment Hotspots
 - **Do not send network name (SSID)** - Turn Infotainment hotspot visibility on/off
 - **Store** - Storage of Infotainment hotspot parameters

Network settings

Applies to the infotainment Columbus with seated in the external module SIM card as well as for the Infotainment Amundsen with the connected Carstick-Device.

- › Tap the **[MENU]** sensor field and then the function surface  → **Network**.
- **Network settings** - Sets the data connection from the associated telephone service provider (APN settings)
 - **Access point name: ...** - Setting of the access point name
 - **User name: ...** - Setting of the user name
 - **Password: ...** - Password setting
 - **Authentication**: Sets the check type
 - **Normal** - Without verification
 - **Secure** - Verification required
 - **Reset Access Point (APN)** - Delete the parameters for the network setting
 - **Store** - Storage of the parameters for the network setting
- **Network provider: ...** - Selection of the network provider (the menu item is visible when the SIM card is inserted in the external module or CarStick device)
- **Data roaming** - Enable / disable the use of data roaming connection
- **Current connection details** - Display of information on data downloaded (by tapping the function surface **Reset** the data information is deleted)
- **Data connection**: Usage settings for the data connection (Internet connection) of the SIM card inserted in the external module or CarStick device
 - **Off** - Use of the data connection is not possible
 - **Ask** - Use of the data connection is only possible after it has been confirmed
 - **On** - Use of the data connection is possible at any time

ŠKODA Connect Online Services settings

- › Tap the **[MENU]** sensor field and then the function surface  → **ŠKODA Connect (Online Services)**.
- **Services Management** - Information on licensing of the respective online services and the option to switch them on / off
- **registration** - Enter the registration PIN code for online services (in the user profile on the website ŠKODA Connect Portal receive)

System information

- › Tap the **[MENU]** sensor field and then the function surface  → **System information**. ▶

The information available will be displayed, for example regarding the Infotainment hardware and software, the Bluetooth® software version, the navigation database version, etc.

- To **Update** the Infotainment software, Bluetooth® software version, etc., tap on the function surface **Update software**.
- To **Update** the navigation database and the POI categories created in the user profile on the ŠKODA Connect Portal website, tap on the function surface **Online update**.

The information on available software updates is obtained from a ŠKODA Partner or from the following ŠKODA Internet pages.

<http://go.skoda.eu/updateportal>

Menu Settings Radio

Settings for all broadcasting ranges

- In the main *Radio* menu, tap the function surface .
- **Sound** - sound settings
- **Scan** - Automatic playback of short portions of all available stations in the current frequency range
- **Arrow buttons** - Setting the function of the function surfaces <|>
 - **Preset list** - Change between stations stored under the preset buttons
 - **Station list** - Change between all available stations of the selected broadcasting range
- **Traffic programme (TP)** - Switches TP traffic programme on/off
- **Delete presets** - Deletes station buttons
- **Station logos** - manual management of station logos
- **Radio text** - Switching the text display radio (FM and DAB) on and off
- **Advanced settings** - further settings that are different depending on the selected broadcasting range (FM and DAB)

Advanced settings (FM)

- Select the FM band in the *Radio* main menu and tap on the function surface  → **Advanced settings**.
- **Autostore station logos** - Automatic storage of the station logos
- **Region for station logo** - Setting the region for station logo

- **Automatic frequency control (AF)** - Activates/deactivates the search for alternative frequencies of the station currently being played
- **Radio Data System (RDS)** - enable/disable RDS function (receiving additional information from the station)
- **RDS Regional**: Switch on/off automatic tracking of related regional stations
 - **Fixed** - Maintains the selected regional station continuously. When the signal is lost, another station must be set manually.
 - **Automatic** - Auto-selects the station with the best reception at the moment. If you lose reception in the given the region, Infotainment will automatically set another available region.

Advanced settings (DAB)

- In the *Radio* main menu, select the DAB range and tap on the function surface  → **Advanced settings**.
- **Autostore station logos** - Automatic storage of the station logos
- **DAB traffic announcements** - Switch on/off DAB traffic announcements
- **Other DAB announcements** - Switch on/off other announcements (e.g., warnings, regional weather, sports reports, financial news)
- **DAB - DAB station tracking** - Switch on/off automatic DAB station tracking on another frequency or in other station groups
- **Automatic DAB - FM switching** - Switch on/off auto-switching from DAB to the FM broadcasting range if the DAB signal is lost
- **Switch to a similar station** - Activate/deactivate automatic switching to another station with similar content in the event of signal loss (applies to Infotainment Columbus)
- **L-band** - Enable / disable the availability of L-band

Automatic change from DAB to FM

If DAB reception is poor, the device tries to find an FM station.

The station name is followed by (FM) while the station is being received on the FM band. When the corresponding DAB station is can be received again, the system automatically switches from FM to DAB.

If a DAB station is also not available in the FM band due to poor reception, Infotainment will be switched to mute.

L-band

For the DAB radio reception in different countries, different broadcasting ranges are used. In some countries the DAB radio reception is only possible in the so called L-band. ▶

If no L-band DAB radio reception is possible in the country then we recommend turning off the L-band. The channel scan is therefore faster.

Media menu settings

› Tap on the function surface in the *Media* main .

- **Sound** - sound settings
- **Manage Jukebox** - Administration (record / delete) supported files (audio / video) in Infotainment internal memory (applies to Infotainment Columbus)
- **Mix/repeat including subfolders** - Switching the title display including subfolders
- **Bluetooth** - Settings for the Bluetooth® function
- **WLAN** - Wi-Fi settings (applies to Infotainment Columbus, Amundsen)
- **Video (DVD) settings** - Setting the parameters of the DVD video (applies to Infotainment Columbus)
- **Remove safely**: - Safe removal of the external device
- **Traffic programme (TP)** - Switches traffic programme on/off

Image menu settings

› In the *images* main menu, tap on the function surface .

- **Image view**: - Image view settings
 - **Full** - Display the maximum image size while retaining the aspect ratio
 - **Automatic** - Full screen display
- **Display time**: - Set the display time for the slideshow
- **Repeat slideshow** - Switching on/off the slideshow repeat

Video DVD menu settings

Only valid for Infotainment Columbus.

› In the *Video DVD* main menu, tap on the function surface .

Depending on the DVD some of the following menu items are displayed.

- **Format**: - Set the screen width/height ratio
- **Audio channel**: - Select the audio channel
- **Subtitles**: - Subtitle selection
- **Enter/change PIN for parental settings** - Management of the PIN code for parental control
- **Parental control**: - Parental control settings

Settings

› In the *Telephone* main menu, tap on the function surface .

- **Hands-free** - Switch a call to the telephone/back to Infotainment (the menu item is displayed during a call)
- **Select mobile phone** - Search for available telephones/list of paired telephones/select telephone
- **Bluetooth** - Bluetooth® settings › [page 138](#)
- **User profile** - User profile settings
 - **Manage favourites** - Set the function surfaces for your favourite contacts
 - **Mailbox number**: - Enter the mailbox phone number
 - **Network selection** - Select the telephone service provider of the SIM card inserted in the external module (valid for Infotainment Columbus with the SIM card slot in the external module)
 - **Priority assignment**: - Select the phone service priority of the SIM card inserted in the external module (applies to Infotainment Columbus with the SIM card slot in the external module)
 - **Automatic** - Depending on the telephone service provider
 - **Telephone call** - telephone calls are preferred
 - **Data transfer** - A data connection is preferred
 - **Sort by**: - Arrangement of telephone contact list
 - **Surname** - Sort by contact name
 - **1st name** - Sort by contact's first name
 - **Profile name**: Rename the profile of the SIM card inserted in the external module (applies to Infotainment Columbus with the SIM card slot in the external module)
 - **Import contacts**: - Import telephone contacts
 - **Select device contacts** - Open the coupled Telephones menu (applies to Infotainment Columbus with the SIM card slot in the external module - if the SIM card is inserted in the external module)
 - **Select ring tone** - Select the ring tone (depending on the connected phone)
 - **Reminder: Remember your mobile** - Turn on/off the warning mode before forgetting the phone in the vehicle (if the phone was connected to the device)
 - **Show pictures for contacts** - Switch on/off the display of the image assigned to the contact
- **Conference call** - Activates/deactivates conference calls ▶

- **Call settings:** - Setting the phone functions of the SIM card inserted in the external module during a call (applies to Infotainment Columbus with the SIM card slot in the external module)
 - **Hold call:** - Switch the display of the option for answering an incoming call during a call on/off; determine the current divert setting
 - **On** - Turn on the display
 - **Off** - Turn off the display
 - **Request status** - Checking the settings of the SIM card function
 - **Send own number:** - Sets the telephone number display for the call receiver
 - **On** - Turn on the display
 - **Off** - Turn off the display
 - **Network dependent** - Telephone service provider dependent display
 - **Request status** - Checking the settings of the SIM card function
- **Delete calls** - Delete the selected call type performed via the SIM card inserted into the external module or via a telephone connected to Infotainment by the Bluetooth® profile rSAP (applies to Infotainment Columbus with the SIM card slot in the external module)
 - **All areas** - Delete all calls
 - **Missed calls** - Delete list of missed calls
 - **Dialled numbers.** - Delete outgoing calls
 - **Received calls** - Delete list of received calls
- **Text message settings** - Text message settings for the sim card inserted in the external module or in the telephone connected to Infotainment by the Bluetooth® profile rSAP (applies to Infotainment Columbus with the SIM card slot in the external module)
 - **Standard account** - Setting for the use of text messages (only visible when the SIM card is only used for data services while a telephone is connected to the Infotainment that supports the Bluetooth® profile MAP)
 - **No standard account** - Without priority (selection of the SIM card or the connected telephone required)
 - **SIM** - A list of text messages on the SIM card
 - **MAP** - A list of text messages of the connected telephone
 - **Service centre number:** - Setting the number of SMS services of the telephone service provider
 - **Store sent text messages** - Enable / disable the storage of the text message on the SIM card
 - **Period of validity:** - Adjustment of the period in which the telephone service provider will try to deliver a text message (for example, if the recipient is not available or Infotainment is switched off.)
- **Delete text messages** - Delete the data stored on the SIM card text messages
 - **All** - Delete all text messages
 - **Inbox** - Delete the text messages received
 - **Outbox** - Delete draft text messages
 - **Sent** - Delete sent text messages
- **Telephone Interface "Business"** - Turn on / off the Telephone function of the external module (applies to Infotainment Columbus with the SIM card slot in the external module)
- **Use SIM card only for data connection - turn on / To turn off** - Activation of data and telephone services of the SIM card inserted in the external module (valid for Infotainment Columbus with the SIM card slot in the external module)
- **Network** - Setting of the telephone service provider for the sim card inserted in the external module or in the telephone connected to Infotainment by the Bluetooth® profile rSAP (applies to Infotainment Columbus with the SIM card slot in the external module)/the SIM card inserted in the CarStick device (applies to Infotainment Amundsen) » [page 138](#)
- **PIN settings:** - Setting the PIN code of the SIM card inserted in the external module (applies to Infotainment Columbus with the SIM card slot in the external module)
 - **Automatic PIN entry** - Enable / disable the storage of the PIN code of the SIM card
 - **Change PIN** - Change the PIN code of the SIM card
 - **Add PIN 2.** - Enter the second PIN code of the SIM card (when the function **Automatic PIN entry** is on or when the SIM card supports another Telephone service provider)
- **Forward calls** - Setting diversion of incoming calls (valid for Infotainment Columbus with the SIM card slot in the external module)
 - **All calls** - Forward all incoming calls
 - **If engaged** - Forwarding incoming calls during a telephone conversation
 - **Unavailable** - Forwarding the incoming calls when the vehicle is outside the range of the telephone service provider signal
 - **If no answer** - Redirecting incoming calls when the incoming call is not answered







SmartLink+ menu settings

› In the main *SmartLink* menu, tap on function surface  .

- **Activate data transfer for ŠKODA apps** - Activate/deactivate data transfer for ŠKODA applications
- **MirrorLink®** - Settings of the system MirrorLink®
 - **Allow MirrorLink® notification to be shown** - Activate/deactivate the display of Mirror link® application messages on the Infotainment screen

Navigation menu settings

Route options

- › In the *Navigation* main menu, tap the functional surface  → **Route options**.
- **Suggest 3 alternative routes** - Switch on/off the menu for alternative routes (economical, fast, short)
- **Route** - Setting the preferred route
- **Freq. Routes** - Show/hide the menu of the most frequent routes in the split screen
- **Dynamic route** - Switch on/off dynamic route recalculation due to TMC traffic reports or online traffic reports
-  **Avoid motorways** - Switch on/off the non-use of motorways in the route calculation
-  **Avoid ferries and motorail trains** - Switch on/off the non-use of ferries and motorail trains in the route calculation
-  **Avoid toll roads** - Switch on/off use of toll roads for the route calculation
-  **Avoid tunnels** - Switch on/off use of tunnels for route calculation
-  **Avoid routes requiring toll stickers** - Switch use of routes requiring toll stickers on/off for route calculation
 - **Show available toll stickers** - Selection of countries for which a valid toll sticker is required (routes requiring toll stickers are used for route calculation)
-  **Include trailer** - Turn on / off the setting to take a trailer into account for route calculation » [page 194](#)

Map

- › In the *Navigation* main menu, tap the functional surface  → **Map**.
- **Show road signs** - Switch on/off the display of traffic signs
- **Lane guidance** - Display of lane guidance on/off
- **Show favourites** - Switch on/off the display of favourites

- **Show POIs** - Switch on/off the display of POIs
 - **Select categories for POIs** - Selection of the displayed category for POIs
 - **Show brand logos for POIs** - Switch on/off the company logos available for the POIs shown
- **Map view in the instrument cluster** - Settings of the map display in the digital instrument cluster (applies to vehicles with Infotainment Columbus and the digital instrument cluster)
 - **2D North** - two-dimensional map, oriented towards the north - the map does not rotate
 - **2D heading up** - two-dimensional map display, aligned with direction of travel - the map rotates
 - **3D heading up** - three-dimensional map display
- **Traffic flow settings** - Setting the display of a traffic obstruction received from online traffic
 - **Display free-moving traffic** - Enable / disable the display of routes with free-moving transport
 - **Display congestion** - Enable / disable the display of routes with heavy traffic
 - **Display traffic events (symbols on map)** - Activate/deactivate the display of routes with a traffic incident

Manage memory

- › In the *Navigation* main menu, tap the functional surface  → **Manage memory**.
- **Sort contacts**: - Setting the configuration of the phone book
 - **By surname** - Sorting by the contact surname
 - **By first name** - Sorting by the contact first name
- **Define home address** - Enter the home address
- **Delete My POIs** - Deleting own POI categories (Personal POI)
- **Update "My POIs" (SD/USB)** - Import / update your own POI categories (Personal POI)
- **Retrieve "My POIs" (online)** - Online import / update of the user profile on the website ŠKODA Connect Portal started own POI categories
- **Import destinations (SD/USB)** - Import destinations in vCard format
- **Delete user data** - Delete user data (by pressing the function surface **Delete** and confirm the deletion)
 - **Last destinations** - Delete the last destinations
 - **Dest. memory** - Delete the stored destinations
 - **Online destinations** - Delete the stored online dests
 - **Routes** - Delete saved routes
 - **My points of interest (Personal POI)** - Delete the custom POIs

- **Entered cities** - Delete the history of places already entered via the address
- **Home address** - Delete the stored home address
- **Flagged destination** - Delete the flagged destination
- **Waypoints** - Delete item in the **Waypoint mode** menu (applies to Infotainment Columbus)
- **Freq. Routes** - Delete the most travelled routes

Nav. announcements

- › In the *Navigation* main menu, tap the functional surface  → **Navigation announcements**.
- **Volume** - Volume control of the nav. announcements
- **Entertainment fading (Navigation)** - Adjust the fading of the audio volume (e.g. radio volume) when navigation announcements are being made
- **Navigation announcements:** - Setting the playback method for navigation announcements (applies to Infotainment Columbus)
 - **Comprehensive** - All nav. announcements
 - **Brief** - Short nav. announcements
 - **Congestion only** - Only nav. announcements when a route is changed
- **No navigation sound during call** - Enable / disable non-playback of nav. announcements during a telephone call
- **Note: "My POIs"** - Activate/deactivate an audible indication when approaching a custom POI (if supported by the imported custom POI)

Top speeds

- › In the *Navigation* main menu, tap the functional surface  → **Speed limits**.

The speed limits in the current country are displayed.

When this function is activated **Note: National border crossed** » [page 143](#), *Advanced settings*, display the country-specific speed limits when crossing international borders.

Tank options

- › In the *Navigation* main menu, tap the functional surface  → **Fuel options**.

- **Select preferred fuel station** - Select your preferred fuel station brand (the selected station brand will be displayed in the first three positions of the list)
- **Fuel warning** - Turn on- / Off the display of a warning message with the option to visit the nearest petrol station when the fuel level reaches the reserve area

Version information

- › In the *Navigation* main menu, tap the function surface  → **Version information**.

A list of countries shown, for whom navigation data exists, together with the date of the last update.







An update of the navigation data can be carried out by tapping the function surface **Update (SD/USB)** or **Update (online)** (applies to Infotainment Columbus).

The information on updating the navigation data is to be obtained from a ŠKODA partner or on the following ŠKODA Internet pages.

<http://go.skoda.eu/updateportal>

Advanced settings

- › In the *Navigation* main menu, tap the functional surface  → **Advanced settings**.

- **Time display:** - Select the time display in the status line
 -  - Estimated arrival time at destination
 -  Estimated travelling time to the destination
- **Status line:** - Selection of the destination type, for which the status line, the route and travel time are displayed (this also determines which destination type is displayed on the map after selecting  →  is displayed on the map)
 -  - Route destination
 -  - Next waypoint
- **Note: National border crossed** - Switching the display of information on country-specific speed limits when crossing a national border on/off
- **Demo mode** - Switch on/off guidance in demo mode
 - **Define demo mode starting point** - Specifying the start point of the route guidance in the demo mode by entering the address or the current vehicle position

Infotainment settings - Swing

Infotainment system settings

Sound settings

- › Press the **SOUND** or **SETUP** button, then tap the function surface **Sound**.
- **Volume** - Volume settings
 - **Maximum switch-on volume** - Setting the maximum volume when switching on Infotainment
 - **Announcements** - Adjustment of traffic announcements volume (TP)
 - **Speed-dependent volume adjustment** - volume increases as speed increases
 - **Entertainment fading (parking)** - Lowers the audio volume (e.g. radio volume) with activated parking aid
 - **Entertainment fading (Navigation)** - Reduction of audio volume (e.g. radio volume) for navigation announcements originating from the SmartLink application
 - **Bluetooth audio**: - Volume setting of the device connected via Bluetooth® audio profile
- **Balance - Fader** - Sets the balance between left and right, front and rear
- **Bass - Mid - Treble** - Setting the equalizer
- **Touchscreen tone** - Switch on/off audible tone when touching the screen

Screen settings

- › Press the **SETUP** button, then tap the function surface **Screen**.
- **Switch off screen (in 10 seconds)** - Enable/disable the automatic power off function
- **Display clock when screen is off** - Time and date display when the screen is switched off
- **Brightness**: - Adjusts the brightness of the screen
- **Touchscreen tone** - Switch on/off audible tone when touching the screen
- **Show clock in standby mode** - Time and date displayed on the screen when the ignition is switched on and Infotainment is switched off

Time and date settings

- › Press the **SETUP** button, then tap the function surface **Time and date**.

- **Time**: - Time settings
- **Time format**: - Set the time format
- **Summer (DST)** - Switches summer time on/off
- **Automatic summer time** - Switches the automatic switch to summer time on/off
- **Date**: - Date settings
- **Date format**: - Set the date format

Setting the Infotainment language

- › Press the **SETUP** button, then tap the function surface **Language**.
- › Select the Infotainment language.

Additional keypad language settings

- › Press the **SETUP** button, then tap the function surface **Additional keypad languages**.

In this menu, a keyboard language set can be added to allow the entering of characters other than those in the currently selected language.

Unit settings

- › Press the **SETUP** button, then tap the function surface **Units**.
- **Distance**: - Distance units
- **Speed**: - Speed units
- **Temperature**: - Temperature units
- **Volume**: - Volume units
- **Fuel consumption**: - Fuel consumption units
- **Pressure**: - Pressure units for tyre pressure

Setting data transfer

Activated data transfer enables data transfer between the Infotainment and an external device.

- › Press the **SETUP** button and then tap on the function surface **Activate data transfer for ŠKODA apps**.

Safe removal of the data source

- › Press the **SETUP** button, then tap the function surface **Remove safely** and select the external device to be removed.

Restore factory settings

- Press the **SETUP** button, then tap the function surface **Factory settings**.

In this menu individual settings or all settings can be restored at the same time.

Bluetooth® settings

- Press the **SETUP** button, then tap the function surface **Bluetooth**.
 - **Bluetooth** - Switch on/off Bluetooth® function
 - **Visibility**: Switch the visibility of the Bluetooth® device for other Bluetooth® devices on/off
 - **1st name** - Changing the name of the Bluetooth® unit
 - **Paired devices** - Display the list of coupled Bluetooth® Devices
 - **Find devices** - Searches for available Bluetooth® devices
 - **Bluetooth audio (A2DP/AVRCP)** - Turn on/off the ability to connect a Bluetooth® audio device (e.g. MP3 player, tablet etc...)

Settings of online services ŠKODA Connect

- Press the **SETUP** button, then tap the function surface **ŠKODA Connect (online services)**.
 - **Services Management** - Information on licensing of the respective online services and the option to switch them on/off
 - **registration** - Enter the registration PIN code for online services (in the user profile on the website ŠKODA Connect Portal receive)

System information

- Press the **SETUP** button, then tap the function surface **System information**.

The information available will be displayed, for example regarding the Infotainment hardware and software, Bluetooth® software version, etc.

- To **Update** the Infotainment software, Bluetooth® software version, etc., tap on the function surface **Update software**.

The information on available software updates is obtained from a ŠKODA Partner or from the following ŠKODA Internet pages.

<http://go.skoda.eu/infotainment>

Radio menu settings

Settings for all broadcasting ranges

- In the main **Radio** menu, tap the function surface .
- **Scan** - Automatic playback of short portions of all available stations in the current frequency range
- **Sound** - sound settings
- **Arrow buttons**: - Setting the function of the function surfaces <|>
 - **Presets** - Change between stations stored under the preset buttons
 - **Stations** - Change between all available stations of the selected broadcasting range
 - **Traffic programme (TP)** - Switches traffic programme on/off
 - **Radio text** - Switching the text display radio (FM and DAB) on and off
 - **Sort channel list**: - Sort types of radio stations in the station list (FM)
 - **Group** - Sort by transmitted program type
 - **Alphabetically** - Alphabetical sorting according to station name
 - **Station logos** - manual management of station logos
 - **Delete presets** - Delete the stations stored under station buttons
 - **Advanced settings** - further settings that are different depending on the selected broadcasting range(FM and DAB)

Advanced settings (FM)

- Select the FM band in the **Radio** main menu and tap on the function surface  → **Advanced settings**.
 - **RDS Regional**: Switch on/off automatic tracking of related regional stations
 - **Automatic** - Auto-selects the station with the best reception at the moment. If you lose reception in the given the region, Infotainment will automatically set another available region.
 - **Fixed** - Maintains the selected regional station continuously. When the signal is lost, another station must be set manually.
 - **Automatic frequency control (AF)** - Activates/deactivates the search for alternative frequencies of the station currently being played
 - **Radio Data System (RDS)** - enable/disable RDS function (receiving additional information from the station)
 - **Sort channel list**: - Sort types of radio stations in the station list (FM)
 - **Group** - Sort by transmitted program type
 - **Alphabetically** - Alphabetical sorting according to station name

Advanced settings (DAB)

- › In the *Radio* main menu, select the DAB range and tap on the function surface  → **Advanced settings**.
- **DAB traffic announcements** - Turn on / off DAB announcements
- **Other DAB announcements** - Switch on/off other announcements (e.g., warnings, regional weather, sports reports, financial news)
- **DAB - DAB station tracking** - Activate/deactivate automatic DAB station tracking on another frequency or in other station groups
- **Automatic DAB - FM switching** - Enable/disable auto-switching from DAB to the FM frequency band if the DAB signal is lost

DAB program tracking

When a DAB transmitter is a part of several broadcast stations and if the current station group is not available on any other frequency, then when the signal is poor, the same station will be searched in another station group.

Automatic change from DAB to FM

If DAB reception is poor, the device tries to find an FM station.

The station name is followed by (FM) while the station is being received on the FM band. When the corresponding DAB station is can be received again, the system automatically switches from FM to DAB.

If a DAB station is also not available in the FM band due to poor reception, Infotainment will be switched to mute.

Media menu settings

- › Tap on the function surface in the *Media* main menu .
- **Sound** - sound settings
- **Mix/repeat including subfolders** - Switching the title display including subfolders
- **Bluetooth** - Settings for the Bluetooth® function
- **Traffic programme (TP)** - Switches traffic programme on/off
- **Remove safely:** - Safe removal of the external device

Import contactsTelephone menu settings

- › In the *Telephone* main menu, tap on the function surface .

- **Hands-free** - Switch a call to the telephone/back to Infotainment (the menu item is displayed during a call)
- **Select mobile phone** - Search for available telephones/list of paired telephones/select telephone
 - **Find** - search for available Telephones
- **Bluetooth** - Bluetooth® settings » [page 145](#)
- **User profile** - User profile settings
 - **Manage favourites** - Set the function surfaces for your favourite contacts
 - **Sort by:** - Arrangement of telephone contact list
 - **Surname** - Sort by contact name
 - **1st name** - Sort by contact's first name
 - **Import contacts** - Import phone contacts
 - **Select ring tone** - Select the ring tone (depending on the connected phone)
- **Reminder: Remember your mobile** - Turn on/off the warning mode before forgetting the phone in the vehicle (if the phone was connected to the device)
- **Simultaneous calls** - Enable/disable the option to hold two concurrent calls

SmartLink+ menu settings

- › In the main *SmartLink* menu, tap on function surface .
- **Activate data transfer for ŠKODA apps**- Activate/deactivate data transfer for ŠKODA applications
- **MirrorLink®** - Settings of the system MirrorLink®
 - **Connect automatically via Bluetooth** - Activate/deactivate the option of pairing and connecting the external device via Bluetooth®
 - **Allow MirrorLink® notification to be shown** - Activate/deactivate the display of Mirror link® application messages on the Infotainment screen

Radio

service

Introduction to the subject

Depending on the vehicle equipment and the Infotainment type, analogue radio reception of the FM and AM frequency ranges as well as DAB digital radio reception is possible.

! CAUTION

- For vehicles with window antennas do not stick foil or metal coated stickers to the window - Radio signal reception could be affected.
- Car parks, tunnels, tall buildings or mountains can interfere with the radio signal even causing it to fail completely.

main menu

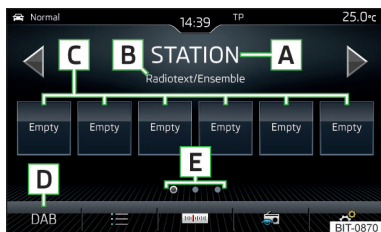





Fig. 194
Radio: Main menu (DAB)

- To **display** the main menu, press the sensor field/the **RADIO** button.
- **or:** Tap the **MENU** sensor field and then the function surface .

Main menu » Fig. 194

- A** The selected radio station (description or frequency)
- B** Radio Text (FM) / Description of the group (DAB)
- C** Preset station buttons for favourite channels
- D** Choice of radio range (FM / AM / DAB)
- E** Choice of storage group for the preferred station
- ◀▶ Changing the station
- ☰ List of available stations
-  Manual / semi-automatic station search

-  Radio text display (DAB) / picture presentation (DAB)
-  Settings of menu *Radio* » [page 139](#) or » [page 145](#)

Information symbol in the status line

Symbol	Meaning
TP	Traffic signal is available
no TP	Traffic signal is not available
	Signal is not available (DAB)

If the displayed station name continuously changes (dynamic text), then it is possible to fix the current text by holding your finger on the device screen in the station name area. By holding your finger in the area of the station name again, the station name is displayed in its entirety again.





Search stations and select frequency

Find stations

- Tap the *Radio* main menu function surface  or .

Depending on the setting  → **Arrow buttons**: will set an available station from the **Stations list** or a station of the current broadcast range on the **Station buttons**.

Select frequency

- To **display the value** of the currently chosen frequency, tap the functional surface in the *Radio* main menu .
- To **Set the desired frequency value** in Infotainment Swing, use the slider or the function surfaces   in the bottom area of the screen, if necessary, turn the controller  (not applicable to Infotainment Columbus)

Scan through the stations one after the other (scan)

The function scans through all the available stations in the current frequency range in succession, for a few seconds each.

- To **start** automatic scanning of the available stations, go to the main *Radio* menu and tap on the function surface  Tap on → **Scan**.
- To **end** autoplay, tap the function **SCAN**.

List of available stations

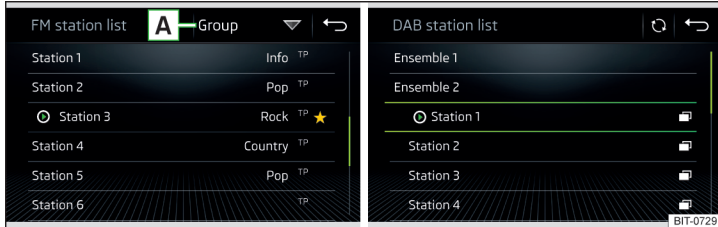

Fig. 195 Example, the list of available FM/DAB stations

Applies to Infotainment Columbus, Amundsen, Bolero

- ▶ To **display** the list of available stations of the currently selected broadcasting area, tap the function surface in the *Radio* main menu: ≡ .
- ▶ To **play**, tap on the function surface of the desired station.
- ▶ To **Sort** (FM) the stations in alphabetical order, by group or genre, tap on the function surface **A** » Fig. 195 » **!**.

Applies to Infotainment Swing

- ▶ To **display** the list of available stations of the currently selected broadcasting area, tap the function surface in the *Radio* main menu: ≡ .
- ▶ To **play**, tap on the function surface of the desired station.
- ▶ To **filter** the stations based on the program type (e.g. Music, Sport etc.) in the FM station list (with activated RDS function) and the DAB station list (with alphabetical sorting of the channel list selected), tap the function surface **A** » Fig. 195.

Information symbols

Symbol	Meaning
★	Radio station, which is stored on a preset button
⏮	Currently played stations
TP	Traffic information station
(e.g.) Pop	Type of program being broadcast (FM)
(e.g.) R2	Type the regional broadcast (FM)
📶	Station reception is not available (DAB)

Symbol	Meaning
📶	The station reception is not secure (DAB) (applies to Infotainment Amundsen, Bolero, Swing)
📺	Station with image broadcasting (DAB) (does not apply to Infotainment Swing)

Refresh list

Depending on Infotainment, updating the station list takes place as follows:

Frequency	Columbus	Amundsen, Bolero	Swing
FM	automatically	automatically	automatically
AM	automatically	manually	manually
DAB	automatically	manually	manually

- ▶ To **manually** update, the tap on functional surface **⌂** » Fig. 195 .

! CAUTION

To sort the stations according to genre, the RDS and AF functions must be switched on. These functions can be set in the *radio* main menu in the FM band by pressing the function surface **⚙** → **Advanced settings**.

Preset buttons for your favourite channels

In every broadcasting range, there are station buttons available to store preferred stations **C** That are split into groups **E** » Fig. 194 on page 147 or .

- ▶ To **save the station currently being listen to on the main menu Radio**, hold down the desired function surface **C** until an acoustic signal sounds.
- ▶ To **save a station in the list of available stations**, keep the function surface of the desired station held down, select the memory group, and then tap the desired station button.

Station logos - Columbus, Amundsen, Bolero

Station logos are stored in the Infotainment memory which are assigned automatically when storing the stations under preset buttons.

Assign station logo automatically

- ▶ to **Disable / Enable** in the *radio* main menu, tap on the function surface **⚙** → **Advanced settings** → **Autostore station logos** .

Assign station logo manually

- › Tap the *Radio* main menu function  → **Station logos**.
- › Tap on an occupied station button and select the data carrier (SD card, USB).
- › Search for and select the desired station logo on the respective data carrier.

Remove station logo manually

- › Tap the *Radio* main menu function  → **Station logos**.
- › Tap on the station button from which you wish to remove a logo.

Note

- The following image formats are supported: jpg, gif, png, bmp.
- We recommend a resolution of up to 500x500 pixels.



Station logos - Swing

The station key of a preferred station can contain the name and the station logo.

Assign a station logo

- › Tap on the *Radio* main menu function  → **Station logos**.
- › Tap on an occupied station button and select the data carrier (SD card, USB).
- › Search for and select the desired station logo on the respective data carrier.

Remove station logo

- › Tap on the *Radio* main menu function  → **Station logos**.
- › Tap on the station button from which you wish to remove a logo.
- › **or:** Tap the function surface  **All areas** to delete the logos of all station buttons at the same time.
- › Confirm / cancel the removal.

Note

- The following image formats are supported: jpg, png.
- We recommend a resolution of up to 400x240 pixels.

Traffic program (TP)

- › To **switch on/off** the traffic monitoring in the main menu *Radio*, tap on the function surface  → **Traffic programme (TP)**.

During a traffic announcement, it is possible to cancel the current announcement if necessary by deactivating the traffic monitoring.

Note

- Should this station not transmit traffic reports or the signal is not available, then Infotainment automatically searches in the background for another TP station.
- During playback in menu *Media* or a station in the AM radio range, traffic news is received from the previously selected FM radio range.

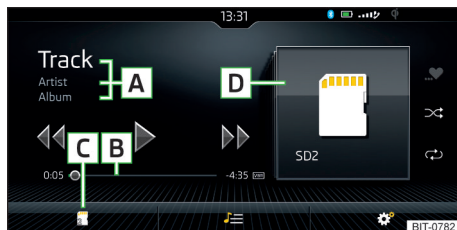

Fig. 196
Media: Main menu display example

- ▶ To **display** the main menu, press the sensor field/the **MEDIA** button.
- ▶ **or:** Tap the **MENU** sensor field and then the function surface **♪**.

Main menu » Fig. 196

- A** Information on playing track
- B** Playback timeline with a slider
- C** Select the audio source
- D** Selected audio source / album image / album overview

☰ Depending on the audio source type:

- ▶ Folder/track list
- ▶ Multimedia Database

⚙ Settings of menu *Media* » page 140 or » page 146

i Note

- Information concerning the track being played appears on the screen, if it is stored as a so-called ID3 Tag on the audio source. If no ID3 tag is available, only the title name is displayed.
- The remaining playback time indicated does not correspond to the actual remaining playback time for titles with variable bitrates.
- When an audio source is connected or plugged in, the Infotainment Columbus searches the local Gracenote® database for information on the track being played (e.g. album name, artist name, genre, album image etc.). If the information is not available and the “Infotainment Online” » page 18 service is active, Infotainment will search for this information in the Gracenote® online database.

Operation	Action
Play / Pause	Tap ▷/⏸
Plays the current track from the start	Tap ◀◀ after 3 s from the start of the track playback
	Finger movement to the right in screen area A » Fig. 196 on page 150 after 3 seconds from the start of the track playback
Fast-reverse within the title	Press and hold ◀◀
Fast-forward within the title	Press and hold ▶▶
Play the previous title	Tap ◀◀ within 3 seconds from the start of the track playback
	Finger movement to the right of the screen area A » Fig. 196 on page 150 within 3 s after the start of the track playback
Play back the next title	Tap ▶▶
	Moving your finger to the left of the screen area A » Fig. 196 on page 150
Switch on/off the random playback from the current album or folder	Tap ⌘
Switch on/off the repeat playback from the current album or folder	Tap ↺
Switch on/off repeat playback of specific track	Tap ↻
Search (applies to sources with a displayable multimedia database) (applies to Infotainment Columbus)	Tap 🔍
Turn on / off playback of similar tracks according to information from the so-called. ID3Tag (applies to Infotainment Columbus)	Tap ...

Movement within the track is possible by touching your finger on the timeline **B** » Fig. 196 on page 150.

Playback control - Swing

Operation	Action
Play / Pause	Tap ▷/⏸
Play the previous title	Tap ◀◀ within 3 seconds from the start of the track playback
Plays the current track from the start	Tap ◀◀ after 3 s from the start of the track playback
Fast-reverse within the title	Press and hold ◀◀
Fast-forward within the title	Press and hold ▶▶
Play back the next title	Tap ▶▶
Switch on/off the random playback from the current album or folder	Tap ⌘
Switch on/off the repeat playback from the current album or folder	Tap ↺
Switch on/off repeat playback of specific track	Tap ↻

Movement within the track is possible by touching your finger on the timeline **B** » Fig. 196 on page 150.

Folder / track list

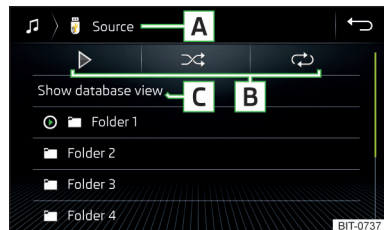

Fig. 197
Folder/Title list

- ▶ To **display** the folder / track list on the *Media* main menu, tap on the function surface \mathbb{E} (if this display is supported by the currently selected source).
- ▶ To **playback** select a title.

Folder/track list » Fig. 197

- A** Selected audio source / audio source folder (movement within the folder is carried out by pressing the function surface for the folder)
 - B** Options folder/track playback
 - C** Display of multimedia database (only available in the source directory) (not applicable to the Infotainment Swing)
- 🎵 Select the audio source
 - 📁 Folder
 - 📁 Playlist
 - ▶ / ⏸ Currently playing title / track playback stopped
 - 🎵 The title cannot be played (tapping on the function surface shows the cause).

i Note

- In the list, the first 1000 entries (titles, directories etc.) are displayed with the oldest creation date.
- The scanning speed of the folder / track list depends on the connection speed and volume of data.

Multimedia database

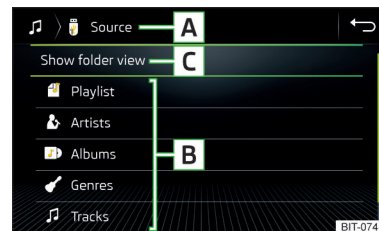

Fig. 198
Multimedia database

- ▶ To **display** the multimedia database, in the *Media* main menu, tap on the function surface \mathbb{E} (if this display is supported by the currently selected source).

The audio files are sorted by their properties into individual categories **B**.

- ▶ To **playback**, select the category and then the title.

Multimedia Database » Fig. 198

- A** Selected audio source / selected category / folder of the audio source
 - B** Sorting categories
 - C** Displays Folder / Track List (only available in the bibliography)
- 🎵 Select the audio source

Audio sources

Introduction to the subject

! CAUTION

- Do not save any important data or that which has not been backed up on the connected audio sources. ŠKODA assumes no responsibility for lost or damaged files or connected audio sources.
- When changing or connecting an audio source, this may cause sudden changes in volume. Reduce the volume before changing or connecting an audio source.
- When connecting an external audio source, the external source information messages can be displayed. These messages must be observed and confirmed if necessary (e.g. enabling data transfer etc).

i Note

The national copyright laws that apply in your country must be observed.

CD / DVD

Only applies to Infotainment Columbus.



Fig. 199 CD / DVD slot

The CD/DVD » Fig. 199 slot is located in an external module in the glove box on the front passenger side.

- ▶ To **insert** a CD/DVD, with the labelled side facing up, into the CD slot until it is automatically drawn in.
- ▶ To **eject**, press the button  The CD/DVD is moved to the starting position.

If the ejected CD/DVD is not removed within 10 seconds, it is retracted again for safety reasons. However, the unit will not change to the CD/DVD source.

! WARNING

- The CD/DVD player is a laser product.
- On the manufacturing date, this unit was classified as a class 1 laser product in accordance with the national/international standards DIN EN 60825-1: 2008-05 and DHHS Rules 21 CFR, Subchapter J. The laser used in this class 1 laser product is so weak that there is no risk of danger when operated correctly.
- This product is designed such that the laser is restricted to the inside of Infotainment. However, the installed laser could be classified in a higher class were the housing to be removed. For this reason, never remove Infotainment housing.

! CAUTION

- Be sure to remove the CD/DVD before you try to insert a new CD/DVD. Otherwise you can damage the drive inside Infotainment.
- Only insert in the CD/DVD drive original audio CDs/video DVDs or standard CD-R/RWs or DVD±R/RWs.
- Do not affix anything to the CD/DVDs!
- If the ambient temperature is too high or too low, the CD / DVD playback may not work.
- Damp (condensation) may affect Infotainment in cold weather or high humidity. This can cause the CD to jump or impair the play function. Once the moisture has dissipated, playback is fully functional again.

i Note

- After pressing the button  it takes a few seconds for the CD / DVD to be ejected.
- On uneven or unpaved roads, playback jumps may occur.

- If the CD/DVD is physically damaged, is not readable or is inserted incorrectly the following message is displayed **Error: CD/DVD**.
- It is possible that CD/DVDs protected by copyright cannot be played back at all or only in certain circumstances.

SD card



Fig. 200
Columbus, Amundsen, Bolero:
Insert the SD card



Fig. 201
Swing: Insert the SD card

Pushing in

- **Insert** the SD card in the slot in the direction of arrow (with the cut end facing right), until it “locks” » Fig. 200 or » Fig. 201.

Removing

- Before **removing** the SD card, go to the main *Media* menu and tap function surface  → **Remove safely**.
- Press on the inserted SD memory card. The SD card “jumps” into the eject position.

! CAUTION

- Do not use an SD card with a broken write protection “slide” - there is a risk of damage to the SD card reader!
- When using an SD card with an adapter, vehicle vibrations might cause the card to fall out of the adapter.

USB input

Installation location of the USB input and information regarding its use
» page 94.

The USB input audio source can be connected directly or via a connecting cable.

- **To connect**, insert the USB audio source into the appropriate input.
- **To disconnect** the USB in the *Media* main menu, tap on the function surface  → **Remove safely**.
- Disconnect the audio source from the corresponding USB input.

Load USB audio source

With the ignition, the charging process starts automatically after the USB audio source is connected (applies to audio sources where charging via the USB connector is possible).

The charging efficiency can differ compared to the charging from the usual mains power supply.

Depending on the type of the connected external device and the frequency of use, the charging current may not be sufficient to charge the battery of the connected device.

Some connected audio sources may not be recognised and cannot be charged.

! CAUTION

USB extension cords, or reducers may impair the function of the connected audio source.

i Note

We recommend that you use extension cords from ŠKODA Original Accessories.

Bluetooth® player

Infotainment allows audio files of a connected Bluetooth® player to play using the A2DP and AVRCP audio profile.

With Infotainment, multiple devices can be paired using Bluetooth®, but only one of them can be used as a Bluetooth® player.

Connect /disconnect

- › To **connect** the Bluetooth® player with Infotainment- follow the same instructions as for pairing Infotainment with a telephone» [page 163](#).
- › To **disconnect** the Bluetooth® player, end the connection in the list of paired external devices » [page 165](#).

Replace Bluetooth® player (applies to Infotainment Amundsen, Bolero)

If you would like to replace a Bluetooth® Player which is connected to Infotainment as a Telephone at the same time, then a relevant information message appears in the Infotainment screen.

- › End the connection to the currently connected Bluetooth® player and repeat the pairing procedure » [page 165](#), *Managing paired external devices*.

! CAUTION



If an external device is connected to Infotainment using Apple CarPlay or Android Auto, then it cannot be connected using Bluetooth®.

Jukebox



Only applies to Infotainment Columbus.

In the Jukebox (in the Infotainment internal memory), supported audio files and » tab. *Supported audio file formats on page 155* video files » tab. *Supported video file formats on page 159* can be imported from connected external devices.

Import files

- › Tap on the function surface in the *Media* main menu  → **Manage jukebox** → **Import**.
- › Select the desired source.
- › Select the desired folders or files.
- › Tap on the function surface .

Delete files

- › Tap on the function surface in the *Media* main menu  → **Manage jukebox** → **Delete**.
- › Select the desired folder or files in the selected category.
- › Tap on the function surface  → **Delete**.

Show level of infotainment memory

- › Tap on the function surface in the *Media* main menu  → **Manage jukebox**.

It displays information about occupied and free space of the Infotainment memory and the number of files that can still be imported.

i Note

- Files that have already been copied are recognised and cannot be copied again (shown in grey).
- It is not possible to copy files while simultaneously playing back audio/video files in the CD/DVD drive.

WLAN

Applies to Infotainment Columbus, Amundsen.

Infotainment allows you to play audio files from one of the external devices connected to the Infotainment WLAN.

- › Connect an external device that supports the DLNA (Digital Living Network Alliance), with Infotainment WLAN» [page 174](#).
- › If necessary use the UPnP application (Universal Plug and Play) in the connected device, which allows playback to start.
- › Select the audio source  **WLAN**.

Supported audio sources and file formats - Columbus, Amundsen, Bolero

Supported audio sources

Source	Interface	Type	Specification	File system
SD card	SD reader	Standard size	SD, SDHC, SDXC	FAT16 FAT32 exFAT NTFS
USB devices	USB 1.x; 2.x and 3.x or higher with support of USB 2.x	MSC	USB stick; HDD (without any special software); USB devices that support MSC operation	
		MTP	Devices with the Android operating system or Windows mobile (mobile phone, tablet)	
		Apple	Devices with the iOS operating system (iPhone, iPod, iPad)	
CD/DVD Only valid for Infotainment Columbus.	CD/DVD Drive	Audio CD (Up to 80 min); CD-R / RW (Up to 700 MB); DVD±R/RW; DVD-Audio. DVD Video	ISO9660; Joliet (Level 1,2,3); UDF 1.x; UDF 2.x	-
Bluetooth®-Player	-	-	Bluetooth logs A2DP and AVRCP (1.0-1.5)	-

Supported audio file formats

Codec type (File formats)	File suffix	Max bit rate	Maximum sampling rate	Multi channels ^{a)}	Playlists
Windows Media Audio 9 and 10	wma	384 kbit / s	96 kHz	no	m3u pls wpl m3u8 asx
WAV	wav	Defined by the format (approx. 1.5 Mbit/s)			
MPEG-1; 2 and 2.5 layer 3	mp3	320 kbit / s	48 kHz	yes	
MPEG-2 and 4	aac; mp4; m4a				
FLAC; Vorbis	flac; ogg	Defined by the format (approx. 5.5 Mbit/s)			

^{a)} Applies to Infotainment Columbus with the CANTON sound system.

The GPT standards (GUID partition table) method structured audio sources are not supported by Infotainment.

Files that are protected by Digital Rights Management (**DRM**) technology cannot be played back by Infotainment.

Supported audio sources and file formats - Swing

Supported audio sources

Source	Interface	Type	Specification	File system
SD card	SD reader	Standard size	SD, SDHC, SDXC	
USB devices	USB 1.x; 2.x and 3.x or higher with support of USB 2.x	MSC	USB stick; HDD (without any special software); USB devices that support MSC operation	FAT16 VFAT FAT32 exFAT
		MTP	Devices with the Android operating system or Windows mobile (mobile phone, tablet)	
		Apple	Devices with the iOS operating system (iPhone, iPod, iPad)	
Bluetooth®-Player	-	-	Bluetooth logs A2DP and AVRCP (1.0-1.5)	-

Supported audio file formats

Codec type (File formats)	File suffix	Max bit rate	Maximum sampling rate	Playlists
Windows Media Audio 9 and 10	wma	384 kbit / s	96 kHz	m3u pls wpl asx
MPEG-1; 2 and 2.5 (Layer-3)	mp3	320 kbit / s	48 kHz	

The GPT standards (GUID partition table) method structured audio sources are not supported by Infotainment.

Files that are protected by Digital Rights Management (**DRM**) technology cannot be played back by Infotainment.

Images

Image viewer

main menu

Applies to Infotainment Columbus, Amundsen, Bolero.



Fig. 202
Images: Main menu

› To **display** the main menu, tap the **[MENU]** sensor field and then tap the function surface **[]**.

Main menu » Fig. 202

[A] Select the image source

[≡ / ≡] Folder / Image List

[◀◀] Display the previous image

[▷] Switching on the slideshow

[⏏] Switching off the slideshow

[▶▶] Display of the next image

[⚙️] Menu settings for *Images* » [page 140](#)

[↺] Rotate the image 90° anticlockwise

[↻] Rotate the image 90° clockwise

[⏏] Display the initial image size while retaining the aspect ratio

[📍] Guidance to GPS coordinates (Amundsen; the display only occurs if the image contains GPS coordinates) (applies to Infotainment Columbus, Amundsen) » [page 189](#)

Control viewed images

Operation	Action
Display of the next image	Finger motion across the screen to the left (with initial representation)
	Tap ▶▶
Display the previous image	Finger motion across the screen to the right (with starting representation)
	Tap ◀◀
Increase the image size	Touch screen using two fingers and pull apart
	Turning the knob ⌚ to the right (not applicable to Infotainment Columbus)
Reduce the image size	Touch screen using two fingers and close together
	Turning the knob ⌚ to the left (not applicable to Infotainment Columbus)
Moving the image with an enlarged display	Drag your finger over the screen in the required direction
Rotate by 90 °	Touch screen using two fingers and move clockwise or counter clockwise (only available with start representation)
	Tap ↻ or ↺
Maximum magnification of representation	Double finger tap on the screen
Display the initial image size while retaining the aspect ratio	Double tap on the screen again
	Pressing the knob ⌚ (not applicable to Infotainment Columbus)

! CAUTION

Viewing images in the Infotainment screen is not supported by connected Apple devices.

Supported image file formats and sources

Supported image sources

Source	Type	Specification	File system
SD card	Standard size	SD, SDHC, SDXC	FAT16
USB devices	USB stick; HDD (without special software)	USB 1.x; 2.x and 3.x or higher with support of USB 2.x	VFAT FAT32 exFAT NTFS
CD / DVD (Applies to Infotainment Columbus)	CD-R / RW (Up to 700 MB); DVD±R/RW	ISO9660; Joliet (Level 1,2,3); UDF 1.x; UDF 2.x	-

Supported file formats

Codec type (File formats)	File suffix	Max. resolution (Megapixels)
BMP	bmp	4
JP (E) G	jpg; jpeg	4; 64
GIF	gif	4
PNG	png	4

i Note

- The max. supported image size is 20 MB.
- The GPT standards (GUID partition table) method structured image sources are not supported by Infotainment.

Video DVD

video player

Main menu

Only applies to Infotainment Columbus.

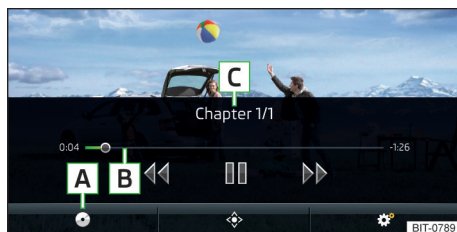

Fig. 203
Video DVD: Main menu

- ▶ To **display** the main menu, insert a CD / DVD in the corresponding slot in the external module.
- ▶ **or:** In the main menu *Media*, select the video source, display the folder/track list and start the video file.

Main menu » Fig. 203

- A** Select a video source
- B** Playback time axis
- C** Information for the selected video file (e.g., video title, chapter)
- ◊ Display the video DVD menu
- ⚙ Video DVD menu settings » page 140

i Note

For safety reasons, the image display is switched off at speeds over 5 km/h. Only the sound continues. The respective message appears on the screen.

Control playback

Operation	Action
Play / Pause	Tap >
Play the previous video	Tap << within 3 s from the start of the track playback

Operation	Action
Play the current video from the start	Tap << after 3 s from the start of the playback
Fast rewind	Press and hold <<< ^{a)}
Play the next video	Tap >>
Fast forward	Press and hold >>> ^{a)}
Forward / rewind the video at the desired time	Tapping the playback time axis B » Fig. 203 on page 158

^{a)} The longer the function surface is held, the faster the fast forward/reverse.

DVD menu

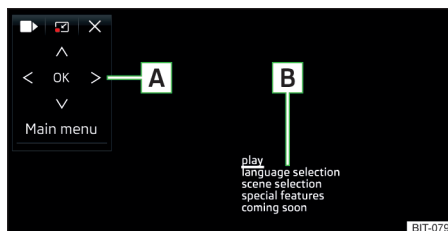

Fig. 204
DVD menu

- ▶ to **display** the DVD menu in the Video DVD main menu, tap on the function surface ◊ » Fig. 203 on page 158 .

Description of the DVD menu » Fig. 204

- A** Operating surface
- B** Example of the displayed menu

Function surfaces on the operating surface

Symbol	Operation
◀ / ▶	Move the operating surface left / right
⌂ / ⌂	Show / hide full screen display of the control surface
×	Close the control surface
<> ∨ ∧	Movement in the EPG/teletext

Symbol	Operation
OK	Confirmation
Main menu	Return to <i>Video DVD</i> main menu

Supported video sources and file formats

Supported video sources

Source	Interface	Type	Specification	File system
SD card	SD reader	Standard size	SD, SDHC, SDXC	
USB devices	USB 1.x; 2.x and 3.x or higher with support of USB 2.x	MSC	USB stick; HDD (without any special software); USB devices that support MSC operation	FAT16 VFAT FAT32 exFAT NTFS
CD/DVD	CD/DVD Drive	CD-R / RW (Up to 700 MB); DVD±R/RW; default DVD; DVD-Video;	ISO9660; Joliet (Level 1,2,3); UDF 1.x; UDF 2.x	-

Supported video file formats

Codec type (File formats)	File suffix	Max. frames per second	Max. resolution
MPEG-1	.mpeg	30	352 x 288
MPEG-2			
MPEG-4	.mp4	25	720 x 576
QuickTime	.mov		
Matroska	.mkv		
DivX; XviD	.avi		
MJPEG			

Media Command

Operation

Introduction to the subject

Applies to *Infotainment Columbus, Amundsen*.



Fig. 205
ŠKODA Media Command application

The Media Command function allows playback of audio files or videos in up to two **Tablets** that are connected to Infotainment via WLAN, **to control Infotainment**.

The Media Command function enables operation of tablets with the operating system Android or iOS.

The prerequisite for the Media Command function is enabled data transfer, the application installed in the tablet “ŠKODA Media Command” as well as Infotainment control approved using the application » [page 132](#).

“ŠKODA Media Command” application

The ŠKODA app is available in the App Store and Google Play online shops.



After entering the following address into the web browser, the website is opened with information on the ŠKODA mobile applications.

<http://go.skoda.eu/service-app>

“ŠKODA Media Command” application

» Scan the QR code » [Fig. 205](#).

Connect tablet to Infotainment

» Switch on the infotainment hotspot (the sensor field)  and then the function area  → WLAN → Mobile hotspot → Mobile hotspot).

» Turn on WLAN in the tablet.

› Establish a WLAN connection in the tablet » [page 173, Connecting via WLAN.](#)

› In the tablet, start the “ŠKODA Media Command” application.

! CAUTION

■ If several devices are connected to the Infotainment system by means of WLAN, there is the danger of WLAN overloading and thus also the inability of Media Command to function properly.

■ High-definition video playback (e.g. HD) may cause playback problems or problems connecting the tablets to the Infotainment system.

Main menu

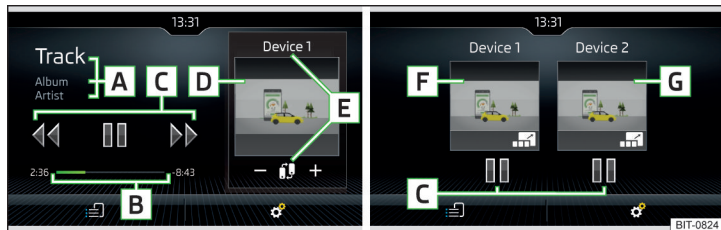

Fig. 206 One tablet / two tablets

› To **display** the main *Media Command* menu, tap the **(MENU)** sensor field and then tap the function surface **(P)**.

Main menu » [Fig. 206](#)

- A** Information on playing track
- B** Playback timeline with a slider
- C** Playback control
- D** Image from the video being played back
- E** Name of the tablet used/Switch to main menu of two tablets (when icon displayed **(P)**)

- / + Increase/decrease the tablet volume

- F** Display of main menu and operation of first tablet (symbol **(P)**)
- G** Display of main menu and operation of second tablet (symbol **(P)**)
- (P)** Selection of the playback source
- (G)** Wi-fi settings » [page 138](#)

Select source and control playback

› To **select the playback source**, in the main menu, tap on the functional surface **(P)** and select the source tablet.

› To **playback**, select the category and then the title.

If two tablets are connected, the title playback starts in the two tablets at the same time.

Playback can be controlled via Infotainment or on each tablet, and are independent from each other. This means there is an option to playback different titles on the tablets at the same time.

Playback control

Operation	Action
Play / pause	Tap (P) / (P)
Plays the current track from the start	Tap (P) after 3 s from the start of the track playback
Play the previous title	Tap (P) within 3 seconds from the start of the track playback
Play back the next title	Tap (P)

Movement within the track is possible by touching your finger on the timeline **(B)** » [Fig. 206 on page 160.](#)

i Note

Some tablet types allow playback of audio files or videos by an inserted SD card in the tablet. Playback of these tracks may be limited.

Supported file formats

Type	Format	operating system Android	Operating system iOS
Video	MPEG-4 Part 2	✓	✓
	MPEG-4 Part 10 (H264)	✓	✓
	XVID	✓	✗

Type	Format	operating system Android	Operating system iOS
Audio	MPEG-1; 2 and 2.5 Layer 3 (mp3)	✓	✓
	AAC	✓ (4.1)	✓
	M4A	✓ (4.1)	✓
	OGG	✓	✗
	FLAC	✓	✗
	WAV	✓ (4.1)	✓

Telephone

Introductory information

Introductory information

! WARNING

The general binding country-specific regulations for operating mobile telephones in the vehicle must be observed.

Telephone

Applies to Infotainment Columbus, Amundsen, Bolero.

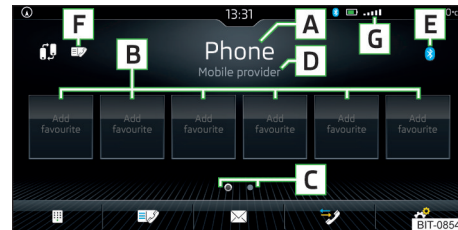

Fig. 207
Telephone: Main menu

The *Telephone* main menu is displayed if a telephone is connected to Infotainment or a SIM card with activated telephone services is inserted in the external module.

- › To **display**, tap the sensor field **PHONE**.
- › **or**: Tap the **MENU** sensor field and then the function surface **☰**.

Main menu » Fig. 207

- A** Name of the connected phone (by tapping the list of paired phones displayed)
- B** Preset station buttons for favourite contacts
- C** Choice of storage group for the preferred contacts
- D** Name of the telephone service provider (with active roaming, the symbol appears before the name ▶)

- E** Main telephone icon
 - ▶ - a telephone connected via Bluetooth®
 - ▶ - a SIM card with activated telephone services, inserted in the external module
- F** List of connected telephones, which are available as the source of telephone contacts
 - ▶ - no telephone is connected for telephone contacts
 - ▶ - a telephone is connected for telephone contacts
- Change the main phone to the extension telephone
- Enter the telephone number
- List of contacts
- Menu with text messages (SMS)
- Call list
- Menu settings for *Telephone* » [page 140](#)

Symbols in the status bar

- G** Signal strength of the telephone network, data connection type if required
- A telephone connected via Bluetooth® (applies to Infotainment Columbus)
- Charge status of the telephone battery
- Missed call
- Current call
- Incoming SMS
- ID of the telephone's wireless charging function » [page 93](#) (applies to Infotainment Columbus)
- PIN** PIN code of the SIM card was not entered

Telephone

Applies to *Infotainment Swing*.



Fig. 208
Telephone: Main menu

The *Telephone* main menu appears when a telephone is connected to Infotainment.

▶ To **display**, press the button.

If another, menu id displayed which was open last, to display the *Telephone* main menu, press the button again .

Main menu » [Fig. 208](#)

- A** Name of the main telephone (tap to display the list of paired telephones)
- B** Preset station buttons for favourite contacts
- C** Choice of storage group for the preferred contacts
- D** Name of the telephone service provider (with active roaming, the symbol appears before the name ▶)
- Enter the telephone number
- List of contacts » [page 167](#)
- Call list (missed calls, in addition to the function surface, the number of calls when missed is displayed)
- Starting voice control of the connected phone (e.g. Apple Siri, Google Voice)
- Menu settings for *Telephone* » [page 146](#)

Symbols in the status bar

- Signal strength of the telephone service network
- Charge status of the telephone battery
- Missed call
- Current call

Pairing and connecting

Introduction to the subject

To connect a telephone with Infotainment, the two devices must be paired via Bluetooth®.

Depending on the Infotainment type, up to 20 external devices can be paired with the device. After reaching the maximum number, the pairing of the next external device will replace that of the device that has not been used for the longest period of time.

Connection to an already paired telephone is established automatically after the ignition is switched on. Or, it is sufficient to search for the phone in the list of paired devices.

The range of the connection to Infotainment is limited to the passenger compartment.

Compatibility and update

By reading the QR code » Fig. 177 on page 125 or after typing the following address into the web browser, information about the compatibility of phones and updates are available for Infotainment Bluetooth® can be displayed.

<http://go.skoda.eu/compatibility>

Conditions for pairing

- ✓ The ignition is switched on.
- ✓ The Bluetooth® function of Infotainment and the telephone is switched on.
- ✓ The visibility of Infotainment and the telephone is switched on.
- ✓ The telephone is within range of the Bluetooth® signal of Infotainment.
- ✓ The telephone is compatible with Infotainment.
- ✓ There is no external device connected to Infotainment using Apple CarPlay.

Pairing and connection process

Pair the telephone with Infotainment

- Search available Bluetooth® devices in your telephone.
- Select the name of the Infotainment system.

The name of the Infotainment system can be checked in the *Telephone* main menu if you tap on the function surface ☎ → **Bluetooth** in the **Name:** menu item.

- Confirm the PIN code (enter and confirm if necessary).

The phone is either connected to the Infotainment or just linked, depending on the number of already connected external devices and on the use of the SIM card inserted in the external module (applies to Infotainment Columbus) » page 164.

Pair Infotainment with the telephone

- If **no** telephone is connected to the Infotainment system, press the button/sensor field **PHONE** and then tap the **Find telephone** function surface or press the **MENU** sensor field, and then tap the function surface ☎ → **Find mobile phone**.
- If **one** telephone is connected to the infotainment system, then, in the *Telephone* main menu, tap on the ☎ → **Find mobile phone** function surface.
- If a **SIM card** with activated telephone services is inserted in the external module of infotainment Columbus, then, in the *Telephone* main menu, tap on the ☎ → **Find mobile phone**.
- Select the desired telephone from the list of visited external Bluetooth® devices.
- Confirm the PIN code (enter and confirm if necessary).

! WARNING

Do not pair and connect a telephone to the Infotainment system while driving the vehicle - there is risk of an accident!

Connect phone using the rSAP profile

Applies to Infotainment Columbus with the SIM card slot in the external module.

A phone that has been connected via the Bluetooth® rSAP profile (remote transfer of SIM data) can be used for **phone and data services**.

Pair the phone with Infotainment

- Turn on the ignition and switch on Infotainment.
- In the *Telephone* main menu, switch on the ☎ → **Business phone** "interface".
- Switch on Bluetooth® visibility in the phone and allow the connection via the Bluetooth® rSAP profile.
- Search for a phone and connect to the device » page 163, *Pair Infotainment with the telephone*.

If the Bluetooth® rSAP profile is supported by the telephone to be connected, then the infotainment system tries to connect to the phone using this profile with priority.

Functional impairment

In the following cases, the phone cannot be connected to Infotainment via the Bluetooth® rSAP profile.

- ▶ The SIM card is plugged into the external module.
- ▶ An external device is connected to Infotainment using Apple CarPlay or Android Auto.

i Note

Vehicle antennas are used to receive the mobile radio signal of the connected phone.

Possible connection types

Depending on the number of connected Bluetooth® devices, connection type, as well as the use of the SIM card in the external module, the following functions are available.

Only applies to Infotainment Columbus

connection version	The first device (main telephone)		The second device (additional telephone)		Third device	Fourth device
	Telephone	SIM card (In the external module)	Telephone	SIM card (In the external module)		
1.	rSAP incoming / outgoing Calls, text messages, telephone contacts, Data connection: Bluetooth® player ³⁾	-	HFP (incoming calls), Bluetooth® player ³⁾	-	Bluetooth® player ³⁾	-
2.	HFP (Incoming / outgoing Calls), text messages, telephone contacts, Bluetooth® player ³⁾	-	HFP (incoming calls), Bluetooth® player ³⁾	Data connection	Bluetooth® player ³⁾	-

connection version	The first device (main telephone)		The second device (additional telephone)		Third device	Fourth device
	Telephone	SIM card (In the external module)	Telephone	SIM card (In the external module)		
3.	HFP (Incoming / outgoing Calls), text messages, telephone contacts, Bluetooth® player ^{a)}	-	-	Incoming calls, text messages Data connection	Bluetooth® player ^{a)}	-
4.	-	incoming / outgoing Calls, text messages, Phone contacts ^{b)} , Data connection	HFP (incoming calls), text messages Bluetooth® player ^{a)}	-	Phone contacts ^{b)} , Bluetooth® player ^{a)}	Bluetooth® player ^{a)}

^{a)} In every connection variant, there is only the option of connecting one external device to Infotainment as a Bluetooth® player.

^{b)} If telephone contacts from the third device are imported into Infotainment, it's not possible to use the telephone contacts of the SIM card inserted in the external module.

Applies to Infotainment Amundsen, Bolero

The first device (main telephone)	The second device (additional telephone)
HFP (Incoming / outgoing calls), SMS, telephone contacts, Bluetooth® player ^{a)}	HFP (incoming calls), Bluetooth® player ^{a)}

^{a)} Only an external device can be connected to Infotainment as a Bluetooth® player.

Applies to Infotainment Swing

The first device (main telephone)	The second device (additional telephone)
HFP (Incoming / outgoing calls), telephone contacts, Bluetooth® player ^{a)}	Bluetooth® player ^{a)}



^{a)} Only an external device can be connected to Infotainment as a Bluetooth® player.

Managing paired external devices

➤ In the *Telephone* main menu, tap on the function surface  → **Bluetooth** → **Paired devices**.

In the list of paired external devices, the following symbols may appear for the individual external devices.



Applies to Infotainment Columbus, Amundsen, Bolero

Symbol	Symbol colour	Operation
	grey	External device can be connected as telephone
	Green	External device is connected as telephone
	grey	External device can be connected as Bluetooth® player
	White	External device is connected as Bluetooth® player

Applies to Infotainment Columbus with the SIM card inserted in the external module

Symbol	Symbol colour	Operation
	grey	An external device can be connected for using telephone contacts and the text message function from this external device
	blue	An external device is connected and using of telephone contacts and the text message function can be carried out from this external device

Applies to Infotainment Swing

Symbol	Symbol colour	Operation
	White	External device can be connected as telephone
	Green	External device is connected as telephone
	White	External device can be connected as Bluetooth® player
	Green	External device is connected as Bluetooth® player

Connection set-up

- ▶ Select the desired external device from the list of paired external devices.
- ▶ Select the desired profile from the list of available Bluetooth® profiles - .

If external Bluetooth® devices are already connected to the device, then during the connection process messages and options for the possible connection type (e.g. replacement of the connected external Bluetooth® device) are displayed.

Disconnection

- ▶ Select the desired external device from the list of paired external devices.
- ▶ Select the desired profile from the list of available Bluetooth® profiles - .

Delete the paired external device

- ▶ To delete, tap on one of the following function surfaces.

 **Delete all or All areas** - Delete all external devices

 - Delete the desired external device

- ▶ Confirm the deletion by tapping on the function surface **Delete**.

Use the SIM card in the external module

Applies to Infotainment Columbus with the SIM card slot in the external module.

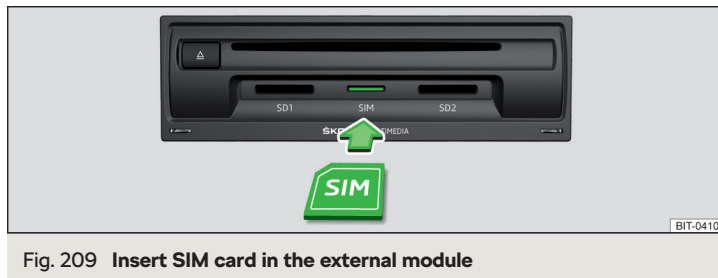

A SIM card size “mini” (standard size 25x15 mm) must be used.

The SIM card can be used for **phone and data services**.

The SIM card slot is located in an external module in the storage compartment on the front passenger side » [Fig. 209](#).

Switching SIM card use on / off in the external module

- ▶ In the *Telephone* main menu, switch on the  → **Business phone “interface”**.

Insert SIM card

- ▶ Insert the SIM card into the appropriate slot » [Fig. 209](#) **With the beveled corner on the left and the contacts facing downwards** until it “locks”.

Using the SIM card for the first time

When using the SIM card in the external module, select the use type.

Calls too - enabling data and telephone services.

Only data connections - enabling of data services only.

Set the network parameters for Internet connection if required » [page 173](#).

By using the SIM card for phone services, the connection to the connected phones is terminated.

Enter the PIN code and save

- ▶ If the SIM card is protected by a PIN code, then the PIN code of the SIM card must be entered. ▶

- › Confirm the entered PIN code by tapping **OK** confirm.
- › **or:** Tap the functional surface **[]** to save and confirm the PIN code.

Change PIN code

- › The PIN code can be changed in the *Telephone* main menu, in the **[]** → **setup** → **Change PIN** menu item

Changing SIM card usage

- › In the *Telephone* main menu, tap on the function surface **[]** → **Use SIM card only for data connection** function surface.

Remove SIM card

- › Press the inserted SIM card and remove it.

! CAUTION

- When inserting an incorrectly sized SIM card, there is a risk of damage to the external module.
- Avoid using an adapter for the SIM card as the SIM card may fall out while driving due to vehicle vibrations - There is the risk of damage to the external module.

Telephone functions

Enter telephone number and select

Enter a telephone number and dial

- › In the *Telephone* main menu, tap the function surface **[]**.

Function surfaces of the numerical keypad

- []** Enter the last dialed number / dial the telephone number entered
- []** / SOS Emergency call (only applies to some countries)
- []** Breakdown call in case of breakdown
- []** / **[]** Information call (for information regarding the products and services of the ŠKODA brand)
- []** Choosing the mailbox number (For Infotainment Swing, the function is not supported)
- []** Delete the last number entered
- []** / **[]** Display of function surfaces **<>** for the movement of the cursor in the input line

Search for a contact using the numeric keypad

The numeric keypad can also be used for a contact search.

For example, if you enter 32, the unit will display contacts with the letter sequence DA, FA, EB, etc. next to the numerical keypad.

Voicemail box (does not apply to the infotainment Swing)

- ▶ To select the voice mailbox number, tap the functional surface **[]**.

If the voicemail number or was not imported or entered, then this can be entered or changed as follows.

- ▶ In the *Telephone* main menu, tap the function surface **[]** → **User profile** → **Mailbox number**.
- ▶ Enter the number of your voice mailbox.

List of telephone contacts

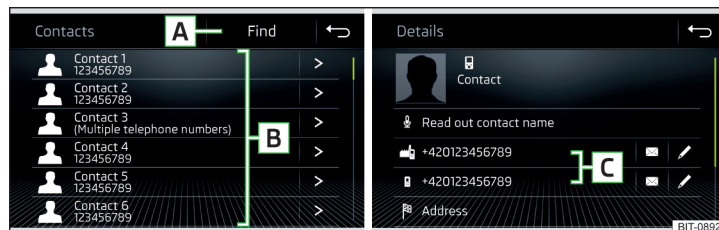

Fig. 210 List of telephone contacts / contact details

- › In the *Telephone* main menu, tap on the function surface **[]** and a list of telephone contacts will be displayed » Fig. 210.

If the main telephone is connected to Infotainment, the telephone contacts from the telephone are used.



If a SIM card with activated telephone services is located in the external module of Infotainment Columbus, the SIM card telephone contacts are available. Another external device to import telephone contacts can be selected by tapping the function surface **[]** » Fig. 207 on page 161.

Function surfaces

- A** Contact search
- B** Dial a number in the telephone contact list (if a telephone contact contains several telephone numbers, a menu containing the telephone numbers assigned to this contact is displayed after the contact is selected)
- > Display the contact details

- C** Select the telephone number in the contact details
-  Processing the telephone number of the contact before dialling

Infotainment Columbus, Amundsen, Bolero:

-  The contact name can be read out by a Infotainment's generated voice
-  Opens the menu for sending a text message (SMS)

Infotainment Columbus, Amundsen:

-  Start the route guidance to the contact address

Import list

After the primary telephone and/or the SIM card (applies to Infotainment Columbus) connects to the infotainment system for the first time, the import of the telephone contacts to the infotainment memory starts. The import can take several minutes.

In the infotainment phonebook, there are 4000 (applies to Infotainment Columbus) and 2000 (applies to Infotainment Amundsen, Bolero, Swing) free storage locations for imported telephone contacts. Each contact can contain up to 5 telephone numbers.

The number of imported contacts can be determined in the menu item  → **User profile** → **Import contacts:** or **Import contacts.**

If an error occurs during the import, an appropriate message appears on the screen.

Refresh list

When the telephone reconnects with Infotainment, the list is automatically updated.

The update can be performed manually as follows.

- ▶ In the *Telephone* main menu, tap on the function surface,  → **User profile** → **Import contacts:** or **Import contacts.**

Management of preferred contacts (favourites)

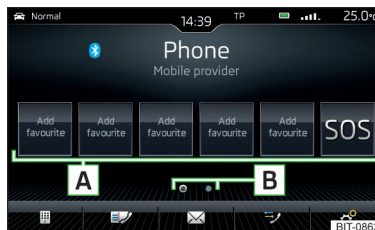

Fig. 211
Favourite contacts

Assigning favourites

- › In the main menu *Telephone*, **tap on** the desired function surface **A** » Fig. 211.
- › Select the desired contact (if necessary one of the contact numbers).

Connecting to a favourite

The functional surfaces of preferred contacts allow for an immediate dial of the contact telephone number.

The favourites are available in two storage groups.

- › To the **change Storage Group** tap on the functional surface **B** » Fig. 211.
- › To **choose** tap on the assigned function area **A** » Fig. 211.

Change allocated favourites

- › In the main *Telephone* menu, **press and hold** the desired function surface **A** » Fig. 211.
- › Select the desired contact (if necessary one of the contact numbers).

Delete a favourite

- › In the *Telephone* main menu, tap on function surface  → **User profile** → **Manage favourites.**
- › Press the desired function surface of the preferred contact and confirm the deletion.

You can delete all contacts by tapping on the function surface  **Delete all / All areas** and confirming the delete process.

Function surface for emergency call sos

If the vehicle is not equipped with the buttons for the Care Connect service » page 17, the position of the last function surface in the first group of favourites will show the function surface for an emergency call sos is displayed in the status bar. In some countries, this function may not be available. ▶

The function surface can be assigned a different number for the preferred contact.

To restore the emergency number, it is necessary to remove the telephone from the list of paired external devices » [page 165](#) and then to pair and connect again.

Call list

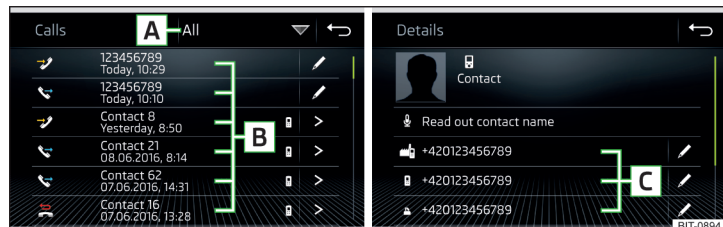

Fig. 212 Call history / Contact details

› In the *Telephone* main menu, tap on the function surface and a call list will be displayed » [Fig. 212](#).

The call list can also be displayed during a telephone call.

Function surfaces

- A** Setting the display depending on the type of call
- ▶ **All areas** - List of all calls
 - ▶ **Missed calls/Missed calls** - List of missed calls
 - ▶ **Dialled numbers** - List of dialled numbers
 - ▶ **Received calls / Received calls** - list of received calls

B Dial the contact number/telephone number

Symbols of the call type

- ▶ - Answered call
 - ▶ - Outgoing call
 - ▶ - Missed call
- Edit the telephone number before dialling (not applicable to Infotainment Swing)
- > Display the contact details » [Fig. 212](#)
- ▶ **C** - Dial the contact number

Phone call

Depending on the conversation context, the following functions can be executed.

- End dialling / reject incoming call / end call
- Accept incoming call / return to held call
- Switch on/off ringer
- Hold a call
- Switch off/on microphone

Infotainment Columbus, Amundsen, Bolero:

- Set up a conference call
- Show caller details (if the contact is stored in the list)

Switch on/off hands-free (call to the telephone / switch to Infotainment)

- ▶ To switch off the hands-free system, in the *Telephone* main menu, tap on the function surface → Tap on **Hands-free** during a call.
- ▶ To switch off the hands-free system, tap on the function surface during a call.

Conference

Applies to *Infotainment Columbus, Amundsen, Bolero*.

The conference call is a shared call with between three and six participants.



Start a conference call/invite additional participants

- › During a call/conference, make the next call.
- › **or:** Take the new incoming call by tapping the function surface .
- › To **initiate conference call or. return to the conference call**, tap on the function surface .

Ongoing conference call

During an ongoing conference call, the call duration is displayed on the screen. Depending on the context, the following functions can be selected.



- Hold a conference call - Leave the conference temporarily (the conference continues in your absence)
- Return to the held conference call
- Switch off/on microphone

-  End conference call
-  Conference call details

Conference details

► During the ongoing conference call, tap on the function surface .

A list of other conference participants is displayed. The following functions can be selected depending on the type of telephone.

-  View details of participant
-  Talk to a participant separately from the conference call
-  End the call to a conference participant

Text messages (SMS)

Main menu

Applies to Infotainment Columbus, Amundsen, Bolero.

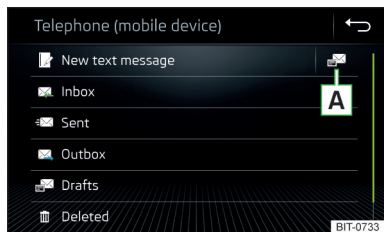











Fig. 213
Main menu text messages

- In the *Telephone* main menu, tap on the function surface  The main menu for text messages appears » Fig. 213.
- If required, select whether the SIM card inserted in the external module or the telephone (applies to Infotainment Columbus) is to be used as the source of the text messages.

Depending on your type of connected telephone, you can perform the following functions.

- A** Opening a list of templates for quick answers
-  **New text message** - Creating and sending the message
-  **Inbox** - Open a list of received messages
-  **Sent** - Open a list of sent messages
-  **Outbox** - Open a list of messages not sent

-  **Drafts**- Open a list of drafts (messages in progress)
-  **Deleted**- Open a list of deleted messages
-  **Send contact details** - Send contact details (business card) (applies to Infotainment Columbus)
-  Select source of text messages (applies to Infotainment Columbus)







Display for the selection of the source of text messages (this applies to the Infotainment Columbus with the SIM card slot in the external module)

If a SIM card used only for data services is located in the external module and if a phone that supports the Bluetooth® profile MAP is connected to Infotainment, then it is possible to adjust the source from which a text message menu will be displayed after tapping on the function surface  in the main *Telephone* menu.

- In the *Telephone* main menu, tap on the function surfaces  → **Text message settings** → **Standard account**.
- Select the desired menu item.





New text message

Creating and sending the message

- In the main menu of the text messages, tap on the function surface  interface» Fig. 213 on page 170.
- Write a text message and confirm. A view of the text message is displayed.
- Tap the function surface  / tap .
- Select the recipient of the message from the displayed contact list or tap on the  and enter the telephone number.
- To add additional recipients, tap on the function surface  / .
- To send the text message, tap the function surface .

Viewing the text message



After opening the view message function, the following functions can be executed.

-  The text can be read out by Infotainment's generated voice
-  The text can be stored as a draft
-  Open a list of templates with the open to replace the recorded text with the selected template
-  /  Open the contact list

The message can be edited, as long as the text range is within the entered view.

Contact list

After the list has been opened the following functions can be executed.







-  Insert a contact in the recipient list
-  Enter the telephone number
-  Return to view the message

Tap on the **Find** function surface to open a list of available telephone contacts.



After selecting the contact number or entering the telephone number, the recipient list will be displayed in the screen.



Recipient list

The following functions can be executed by tapping on one of the functional surfaces.

-  /  Display contact list with the option of adding/removing additional recipients (tap on the function surface to return to the recipient list ).
-  Removal of the contact from the recipient list
-  Sending the message
-  Return to view the message



Received text message

When you receive a new message, the number of new messages received is displayed within the function surface  and at the same time the icon in the status bar  is displayed in the status bar.

- › To **open a list of received messages**, go to the *Telephone* main menu and tap on function surface  → .
- › Select a message.

The message content and the following menu is displayed.

-  The text can be read out by Infotainment's generated voice
- ... Display a menu with additional options
 - ▶ **Reply with template** - Reply using a template
 - ▶ **Delete current text message** - Distance of displayed text message (applies to Infotainment Columbus, when the SIM card is inserted in the external module or the telephone is connected via the Bluetooth®-profile rSAP)
 - ▶ **Display numbers** - Recognition of telephone numbers in the message including the contact number (recognised numbers can be dialled directly or edited before dialling, or may be sent to this message)

-  Forwarding a message with the option to edit the message before sending
-  Reply to the sender via a message

Data connection

Internet connection

Infotainment Columbus

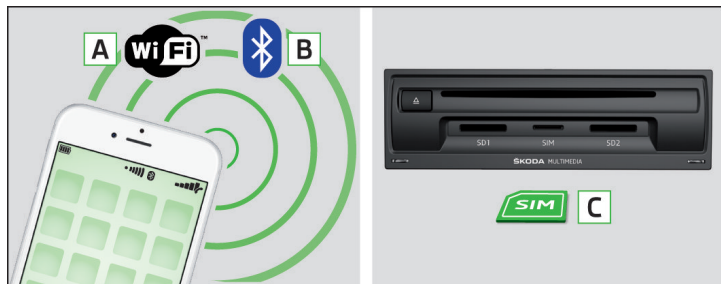

Fig. 214 WLAN (Wi-Fi) / Bluetooth® / SIM card

Possible connection types » Fig. 214

- A** Using WLAN, by connecting the Infotainment system to the hot spot of the external device » [page 174](#), *Connect Infotainment to the hotspot of the external device.*
- B** By connecting to a mobile phone (it is connected to the Internet) using the **Bluetooth® rSAP profile** » [page 173](#), *Establishing a connection using the Bluetooth® rSAP profile.*
- C** Using a **SIM Card** with a data tariff » [page 173](#), *Establishing a connection using a SIM card in the external module.*

Connecting Infotainment Amundsén



Fig. 215 WLAN (Wi-Fi) / CarStick

Possible connection types » Fig. 215

- A** Using WLAN, by connecting the Infotainment system to the hot spot of the external device » [page 174](#), *Connect Infotainment to the hotspot of the external device.*
- B** Using the **CarStick** USB device » [page 172](#).

Connecting via the CarStick device

Applies to Infotainment Amundsén.

The **CarStick** USB device can be purchased from the original accessories.

› Insert a SIM card with activated data services into the **CarStick** device.

The required dimensions of the SIM card, as well as the correct procedure during insertion can be found in the instructions enclosed with the CarStick ŠKODA original accessory.

- › Turn on the ignition and switch on Infotainment.
- › Insert the CarStick into the USB input at the front » [Fig. 110 on page 94](#),
- › Wait approximately one minute until the red light on Carstick stays continuously lit (if the red lights up, then disconnect and re-insert the Carstick).
- › If the SIM card is protected by a PIN code, then the PIN code of the SIM card must be entered.
- › Confirm the entered PIN code by tapping **OK confirm**.
- › **or:** Tap the functional surface  to save and confirm the PIN code. ▶

- › If necessary, set the required network of the data service provider.

If your data provider is not available in the list, ask your provider whether one of the displayed providers can be used.

The parameters of the telephone service provider network can be set in the menu item **MENU** → **Network** → **Network settings**.

! CAUTION

If you insert a SIM card of the wrong size or in the wrong direction, there is a risk of damage to the CarStick device.

Establishing a connection using a SIM card in the external module

Applies to Infotainment Columbus with the SIM card slot in the external module.

A SIM card size “mini” (standard size 25x15 mm) mit enabled data services must be used.

- › Turn on the ignition and switch on Infotainment.
- › In the *Telephone* main menu, switch on the **Business phone** “interface”.
- › Insert a SIM card into the corresponding slot into the external module in the storage compartment on the passenger's side » [Fig. 209 on page 166](#).

Insert the SIM card **with the bevelled corner on the left and the contacts facing downwards** until it “locks”.

- › Select the SIM card usage type:

Calls too - enabling data and telephone services.

Only data connections - enabling of data services only.

- › If the SIM card is protected by a PIN code, then the PIN code of the SIM card must be entered.
- › Confirm the entered PIN code by tapping **OK** confirm.
- › **or:** Tap the functional surface **OK** to save and confirm the PIN code.
- › Set the data service provider's required network and confirm the Internet connection.

If your data provider is not available in the list, ask your provider whether one of the displayed providers can be used.

The parameters of the telephone service provider network can be set in the menu item **MENU** → **Network** → **Network settings**.

The data connection setting using the SIM card can be configured in the **MENU** → **Network** → **Data connection**.

! CAUTION

When inserting an incorrectly sized SIM card or in the wrong direction, there is a risk of damage to the external module.

Establishing a connection using the Bluetooth® rSAP profile

Applies to Infotainment Columbus with the SIM card slot in the external module.

The prerequisite for establishing an Internet connection is using a telephone with a SIM card with active data services.

- › Turn on the ignition and switch on Infotainment.
- › Switch on the “Business” function in Infotainment, the sensor field **MENU** and then the function surface **Phone interface** “Business”.
- › Switch on Bluetooth®, the sensor field **MENU** and then the function surface **Bluetooth** → **Bluetooth**.
- › Turn on Infotainment visibility (tap the **MENU** sensor field and then tap the function surface **Bluetooth** → **Visibility**: → **Visible**).
- › Switch on Bluetooth® and its visibility in the phone.
- › Connect and pair the phone with Infotainment » [page 163](#).

Connecting via WLAN

Introduction to the subject

Applies to Infotainment Columbus, Amundsen.

WLAN can be used to connect to the Internet, to playback audio files in the menu *media* or for operating the Infotainment system using an application in the external device (e.g. “ŠKODA Media Command”).

It is possible to connect up to 8 external devices to the Infotainment hotspot **and at the same time** to connect Infotainment to another hotspot.

Switching the Infotainment hotspot on/off

- › Switch-on the ignition.
- › Switch the hotspot on/off in menu item **MENU** → **WLAN** → **Mobile hotspot** → **Mobile hotspot**.

Setting the Infotainment hotspot

The Infotainment hotspot is factory set.

The setting can be changed in menu item **MENU** →  → **WLAN** → **Mobile hotspot** → **Hotspot (WLAN) settings**.

- **Security level:** - Type of access protection (always set to WPA2)
 - **Network key** - Access password
 - **SSID: ...** - Hotspot name
 - **Do not send network name (SSID)** - Switch the visibility of the hotspot on/off
- ▶ To save the configured parameters, tap the **Store** function surface.

Connecting an external device to the Infotainment hotspot

- › Switch-on the ignition.
- › Switch on WLAN in the external device and search for the infotainment hotspot.
- › Select the Infotainment hotspot and enter the required password.
- › Confirm the connection.

i Note

The name of the Infotainment hotspot (SSID) and the access password can be found in menu item **MENU** →  → **WLAN** → **Mobile hotspot** → **Hotspot (WLAN) settings**.

Connect Infotainment to the hotspot of the external device

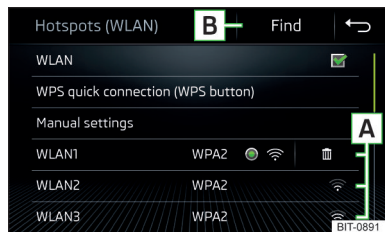



Fig. 216
Main menu of the Infotainment WLAN

The Infotainment system can only be connected to a hotspot with WPA2 access protection.

- › Switch-on the ignition.

- › If the Infotainment WLAN is not activated, activate it in the menu item **MENU** →  → **WLAN** → **WLAN** → **WLAN**.

In area **A** » Fig. 216, a list of available or previously connected hotspots is displayed.

The hotspot list can be updated by tapping the function surface **B**.

- › Select the hotspot and enter the password.

If the hotspot is not visible, you can establish the connection to it manually.

- › Tap the function surface **Manual settings**.
- › Set the required hotspot parameters.
- › Tap the function surface **Connect**.

Icons and function surfaces in the list of available hotspots **A** » Fig. 216

- ⊙ Connected hotspot
- 📶 Signal strength of the connected hotspot
- 🗑️ Delete the hotspot

Hotspot connection recommendations

- ▶ Only leave the hotspot to be connected switched on, switch off the other hotspot.
- ▶ On some hotspots, the connection setup takes longer, wait for the end of the connection setup.
- ▶ If the connection is interrupted, search for available hotspots again and repeat connection setup.
- ▶ Delete unused hotspots. This shortens the time required for connection setup.

i Note

- It is not possible to connect Infotainment Columbus to the hotspot of the external device as long as a SIM card with enabled data services is in the external module of Infotainment or a phone connected to Infotainment via the Bluetooth®rSAP profile.
- An Infotainment Amundsen connection with external device hotspot is not possible, as long as there is an active connection using the Carstickdevice.

Connect via WPS

Applies to Infotainment Amundsen.

It is not necessary to enter the access password when connecting via WPS. ▶

Connecting the Infotainment system to the hotspot of the external device

- › Switch-on the ignition.
- › In the external device, switch on the hotspot, its visibility, and the WPS connection option.
- › In the Infotainment system, switch on WLAN in menu item **MENU** →  → **WLAN** → **WLAN** → **WLAN**.
- › The function surface **WPS fast connection (WPS button)**.

Connecting the external device to the Infotainment hotspot

- › Switch-on the ignition.
- › Switch on the Infotainment hotspot in menu item **MENU** →  → **WLAN** → **Mobile hotspot** → **Mobile hotspot**.
- › The function surface **WPS fast connection (WPS button)**.
- › In the external device, switch on the WPS connection option.

SmartLink

Introductory information

Introduction to the subject



SmartLink offers the ability to display certified applications on an external device equipped with a USB device on the Infotainment screen and to operate them.

SmartLink supports the following communication systems.

- ▶ “Android Auto”
- ▶ “Apple CarPlay”
- ▶ “MirrorLinkSM”

Using the applications in the connected external device it is possible to use the navigation to make a call, to listen to music.

For reasons of safety, the operation of some applications while driving is not possible or only limited.

Read in the QR code » **Fig. 217** or enter the following address in the web browser to open the website with information on the SmartLink communication system.

<http://go.skoda.eu/connectivity-smartlink>

Depending on the model of the connected external device, some applications can be operated via the Infotainment system, using your voice or using the buttons on the multi-function steering wheel.

To activate voice control for the connected external device, hold down **VOICE** or **APP/☺** or hold down the button  on the multifunction steering wheel. ▶

! CAUTION

To establish the connection, it is necessary for the date and time in Infotainment to be set correctly. If the date and time setting is based on the GPS signal, then problems may arise with establishing a connection with a poor GPS signal reception.

i Note

- We recommend that you use extension cords from ŠKODA Original Accessories.
- With some connected external devices, it is necessary for the connected external device to be “unlocked” for trouble-free functioning of the SmartLink function.

Main menu



Fig. 218 Supported communication systems / Example of available communication systems of the connected external device

- › to **display** the SmartLink main menu, tap on the sensor field **APP** or press the **APP/☰** button.
- › **or:** Tap the **MENU** sensor field and then the function surface **SmartLink**.

If no external device is connected, then a menu with supported communication systems SmartLink is displayed **A** » Fig. 218,

Main menu » Fig. 218

- A** Supported communication systems
- B** Available communication systems of the connected external device
- ⓘ Display of information about SmartLink
- ⊗ Disconnection of the active connection
- ⚙ Settings of the SmartLink » page 141 menu or » page 146

Android Auto

Connection set-up / disconnection

Prerequisites for establishing a connection

- ✓ The external device to be connected must support the “Android Auto” communication system.
- ✓ In the external device to be connected, the “Android Auto” application must be installed.
- ✓ Some applications require the data connection in the connected external device to be switched on.

A list external of devices, supported regions and applications that the “Android Auto” connection supports can be found on the websites of Google Inc..

Connection set-up

- › Switch on the ignition.
- › Switch on the Infotainment system.
- › Switch on the external device.
- › Connect the external device to the USB input using a cable » page 94.
- › Select the connection using “Android Auto” **B** » Fig. 218 on page 176.

Disconnection of the active connection

- › In the “Android Auto” main menu, tap the function surface **☰**.
- › Tap the “ŠKODA” function surface to go back to the main menu SmartLink.
- › Tap the function surface **⊗**.
- › **or:** Disconnect the cable from the USB input. When reconnected, the external device is automatically connected.

Function restriction of Infotainment

For the duration of the connection, the external device cannot be used as an audio source in the **Media** menu.

By connecting the external device with “Android Auto”, all currently connected Bluetooth® devices will be disconnected and the external device will automatically be connected as the main telephone.

For the duration of the connection, no Bluetooth devices can be connected to the infotainment system. The SIM card inserted in the external module can only be used for data connection.

If **route guidance is taking place at this moment** in Infotainment, then there is the option to start the route guidance in the “Android Auto” application. And vice versa, if **route guidance is currently taking place** in the “Android Auto” application, then there is the possibility that this will be **terminated** by the start of route guidance by the Infotainment system.

main menu

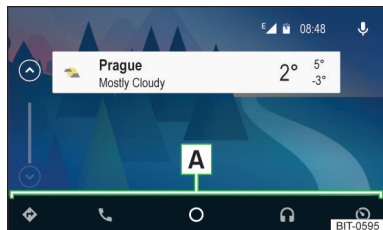

Fig. 219
Android Auto: Main menu

Main menu » Fig. 219

- 📍 Navigation applications
- ☎ Telephone applications
- Overview regarding current applications, telephone calls, accepted text messages, tasks in the working directory, weather or similar.
- 🎵 Music applications
- 📺 Display of other available applications as well as the option of returning to the SmartLink main menu
- 🗣 Switching on voice control (Google Voice)

The symbol appears next to the function surface in the area **A** ▾. Then, by tapping on this function surface again, a list of new applications is displayed.

Apple CarPlay

Connection set-up / disconnection

Prerequisites for establishing a connection

- ✓ The external device to be connected must support the “Apple CarPlay” communication system.
- ✓ The data connection of the external device to be connected must be active.
- ✓ The voice control (Siri) of the external device to be connected must be active.

A list external of devices, supported regions and applications that the “Apple CarPlay” connection supports can be found on the websites of Apple Inc..

Connection set-up

- Switch on the ignition.
- Switch on the Infotainment system.
- Switch on the external device.
- Connect the external device to the USB input using a cable » [page 94](#).
- Select the connection using “Apple CarPlay” **B** » [Fig. 218 on page 176](#).

Disconnection of the active connection

- In the main menu “Apple CarPlay”, tap the function surface of the “ŠKODA” application, the main menu SmartLink is displayed.
- Tap the function surface ⊗.
- **or:** Disconnect the cable from the USB input. When reconnected, the external device is automatically connected.

Function restriction of Infotainment

For the duration of the connection, the external device cannot be used as an audio source in the *Media* menu.

By connecting the external device with “Apple CarPlay”, all currently connected Bluetooth® devices will be disconnected.

For the duration of the connection, no Bluetooth devices can be connected to the infotainment system. The SIM card inserted in the external module can only be used for data services. ▶

If **route guidance is taking place at this moment** using Infotainment, then this is terminated by starting the route guidance in the “Apple CarPlay” application. And vice versa, if **route guidance is currently taking place** in the “Apple CarPlay” application, then this will be **terminated** by the start of route guidance by the Infotainment system.

i Note

Some **phone features** of the connected external device can be operated in the display of the instrument cluster » [page 54](#).

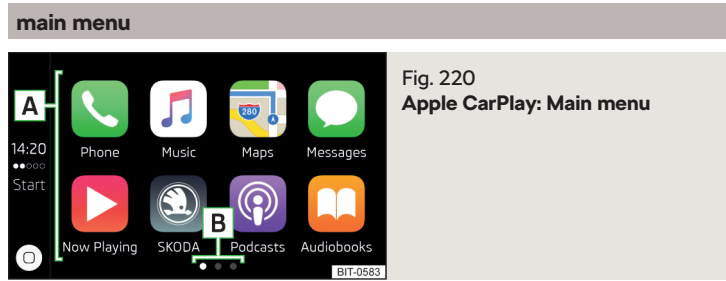

Fig. 220
Apple CarPlay: Main menu

Main menu » [Fig. 220](#)

- A** List of available applications
- B** More pages with applications
- ⊖ Depending on how long the function surface is pressed:
 - ▶ **Tap** - Return to “Apple Carplay” main menu
 - ▶ **Hold** - Switch on voice control (Siri)

MirrorLink®

Connection set-up / disconnection

Prerequisites for establishing a connection

- ✓ The external device to be connected must support the communication system “MirrorLink®”.
- ✓ The external device to be connected must have at least one “MirrorLink®” application installed.
- ✓ Some applications require the data connection in the connected external device to be switched on.

Connection set-up

- › Switch on the ignition.
- › Switch on the Infotainment system.
- › Switch on the external device.
- › Connect the external device to the USB input using a cable » [page 94](#).
- › Select the connection using “MirrorLink®” **B** » [Fig. 218 on page 176](#).

Disconnection of the active connection

- › In the main menu of “MirrorLink®”, tap the function surface . The SmartLink main menu is displayed.
- › Tap the functional surface .
- › **or:** Disconnect the cable from the USB input. When reconnected, the external device is automatically connected.

Function restriction of Infotainment

applies to Infotainment **Columbus, Amundsen, Bolero**: If you wish to use the device to be connected in the *Telephone* menu, the external device must be paired with and connected to the Infotainment system before establishing the connection » [page 163](#).

Applies to Infotainment **Swing**. By connecting the external device to all currently connected Bluetooth® devices will be disconnected and the external device will automatically be connected as the main telephone. Depending on the device to be connected, a connection confirmation may be required.

For the duration of the connection, the external device cannot be used as an audio source in the *Media* menu.

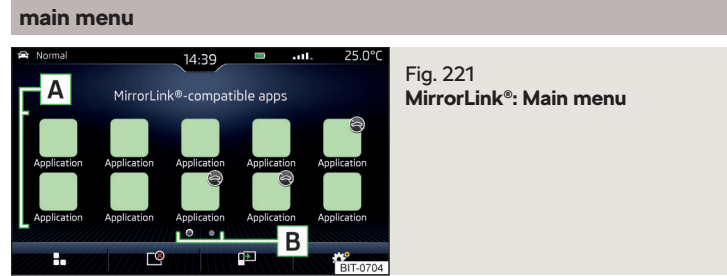

Fig. 221
MirrorLink®: Main menu

Main menu » Fig. 221

- Return to SmartLink main menu » page 176
- ☰ List of running applications
- ☰ Display of the last running application in the connected external device
- ⚙ Settings of the SmartLink » page 141 menu or » page 146
- A** List of applications
- B** More pages with applications
- ⊖ Applications cannot be operated while driving

Display of the function surfaces during the running application

- ☰ Return to “MirrorLink[®]” main menu
- ☰ / ☰ Show function surfaces at the top/bottom (applies to Infotainment Amundsen, Bolero)
- < / > / ∨ / ∧ Move the functional surfaces in the desired corner of the screen (applies to the infotainment Swing)

To show/hide the function surfaces, press the controller ⊖ (applies to Infotainment Amundsen, Bolero).

function problems

If problems occur with the “MirrorLink[®]” connection, then one of the following messages may occur on the screen.

- **Fault: Transfer** - Disconnect and reconnect the external device
- **MirrorLink[®] audio is unavailable.** - Disconnect and reconnect the external device
- **MirrorLink[®] availability on this mobile device is restricted.** - it is not possible to use the connected device during the journey or the device only has limited availability (applies to Infotainment swing)
- **The mobile device is locked. Please unlock the mobile device to use MirrorLink[®]** - “unlock” the connected external device
- **Unable to start app or app not working.** - Disconnect and reconnect the external device

Application “ŠKODA OneApp”

Introductory information



Fig. 222
Information on the ŠKODA OneApp application on the ŠKODA websites

A mobile telephone connected to the Infotainment system allows you to edit and evaluate journey data in the “ŠKODA One App” application.

After entering the following address into the web browser, the website is opened with information on the ŠKODA mobile applications.

<http://go.skoda.eu/service-app>

The “ŠKODA OneApp” application is available in the App Store and Google Play online shops.

“ŠKODA OneApp” application

» Scan the QR code » Fig. 222.

For the full functionality of the “ŠKODA One App” application, data transfer from external devices must be activated.

Applies to Infotainment Columbus, Amundsen, Bolero

► To **activate data transfer from external devices**, tap the **MENU** sensor field and then tap on function surface → ☰ → Mobile device data transfer → Activate data transfer for ŠKODA Apps.

Applies to Infotainment Swing

► To **activate data from external devices**, press the **SETUP** button, then tap on function surface → Activate data transfer for ŠKODA apps.

i Note

Some functions of the application are not available in all countries or there is a function restriction during the journey » page 125, *Mobile devices and applications*.

Connecting to Infotainment

The mobile telephone can be connected to the Infotainment system using the SmartLink function or via WLAN.

Connection by SmartLink

- › Switch on the ignition.
- › Establish the connection via SmartLink (eg “MirrorLink[®]”) » [page 175](#).
- › In the list of available applications, select the “ŠKODA One App” application.

Depending on the model of the connected external device, some applications can be started using voice activation, via the Infotainment screen, using the operating elements on Infotainment, or using the buttons on the multi-function steering wheel.

Once connected, the contents of the application in the infotainment screen may be displayed.

A possible connection between the mobile telephone and the Infotainment system via WLAN will be terminated after a connection is established using SmartLink.

Connection via WLAN (applies to Infotainment Columbus, Amundsen)

- › Switch on the ignition.
- › Establish the WLAN connection » [page 173](#).
- › In the mobile telephone, start the “ŠKODA OneApp” application.

Disconnection

The connection can be switched off in one of the following ways.

- › Switch off the ignition for longer than 5 seconds (for vehicles with a starter button, switch off the engine and open the driver's door).
- › End the connection in the “ŠKODA OneApp” application.
- › Disconnect the mobile telephone from the USB port or terminate the WLAN connection.

Navigation

Introductory information

Navigation - function sequence

Applies to Infotainment Columbus, Amundsen.

Route guidance is started as follows.

- › Search for/ enter a new destination **or** Select one of the stored destinations.
- › Confirm the route calculation in the destination details or if necessary, adjust the route options.
- › Select the preferred route type, if this is requested by Infotainment.

A route calculation occurs and route guidance starts.

The route guidance is provided by graphical nav. announcements.

There is an option to add additional destinations during route guidance, or to adapt the route.

If a traffic radio station is available, information concerning traffic delays is evaluated by Infotainment and, if necessary, an alternative route is offered.

If you deviate from the route, then a new route calculation is carried out.

GPS satellite signal

Infotainment uses the GPS (Global Positioning System) satellite signal for route guidance.

Outside the range of the GPS satellite signal (e.g. in dense vegetation, in tunnels, parking garages, etc.), Infotainment navigates only with restrictions using vehicle sensors.

The unit offers the possibility to show in the split screen display the following **Position** » [Fig. 225 on page 183](#) information about the current geographical position of the vehicle and the satellite signal.

- 📍 Geographical latitude
- 📍 Geographical longitude
- △ Elevation
- 📶 Number of received/available satellites

If no GPS satellite signal is available, no values are displayed.

Columbus navigation data source

The navigation data is stored in the internal Infotainment memory.

Amundsen navigation data source

The navigation data is stored on an **Original** SD card.

In order to ensure the function of the navigation, the Original SD card, with the navigation data, must be inserted in the respective slot in the external module » [page 127](#).

If the original SD card should be damaged or lost, a new original SD card can be purchased from the ŠKODA Original Accessories.

With a **non-original** SD Card, the navigation does **not work**.

Finding out the version of the navigation data

› In the *Navigation* main menu, tap on the functional surface  → **Version information**.

Update navigation data

We recommend that you update the navigation data on a regular basis.

The Infotainment can give incorrect driving recommendations if the road condition or the traffic situation does not match the navigation data. This can lead to route guidance being carried out using a different route or proposing a change of direction in a one-way street. Therefore, observe the respective traffic signs while driving, which always have priority over the driving recommendations.

The information on updating the navigation data is to be obtained from a ŠKODA partner or on the following ŠKODA Internet pages.



<http://go.skoda.eu/updateportal>

When activated online services “Infotainment online” » [page 14](#) can the navigation data for the Infotainment **Columbus** Updating online » [page 181](#), *Navigation data and POI categories Import / Update online*,

Manual update

When “Infotainment Online” » [page 14](#) online services are activated, there is the option of downloading/updating navigation data (applies to Infotainment Columbus) or of downloading POI categories created in the user profile on the “ŠKODA Connect Portal” website.

▶ In the *Navigation* main menu, tap the functional surface  → **Version information** → **Update (online)** → **Retrieve**.

▶ **or:** Tap the  sensor field and then the function surface  → .

A menu for importing/updating the navigation data and POI categories is displayed.

▶ Tap the functional surface  and select one of the following menu items.

- **All** - Import all the available navigation data
 - **Favourites** - Import of navigation data preferably countries / regions (applies to the infotainment Columbus)
 - **POIs** - Import of the POI category created in the user profile on the “ŠKODA Connect Portal” website » [page 189](#)
 - **Maps** - Import of the navigation data available for the respective countries/regions (applies to Infotainment Columbus)
- ▶ Select the desired list entries.
- ▶ Tap on function surface **Retrieve** and confirm the deletion.

Automatic update

Applies to vehicles with the **Infotainment Columbus**: if the online services “Infotainment Online” » [page 14](#) are activated and an update of the navigation data for the current vehicle position or the route destination is available, the infotainment will issue this **automatic** note and offer an update option.

During the upgrade process, infotainment is usable without limitation.

To complete the update of the navigation data, the ignition and Infotainment must be switched off for at least 30 min.

Main menu



Fig. 223 Navigation: Main menu

- ▶ To display, tap the sensor field **NAV**.
- ▶ or: Tap the **MENU** sensor field and then the function surface .

Description of the function interfaces **A** » Fig. 223

 Context-dependent:

Route guidance is disabled - Search / enter a new destination

Route guidance is enabled - The following menu is displayed:



- ▶ **Route details** - Displays the route details » page 196
- ▶ **Change route in map** - Displays a menu for the route change in the map (valid for Infotainment Columbus) » page 197
- ▶ **Congestion ahead** - Manual adjusts traffic conditions » page 202
- ▶ **Enter destination** - Search / enter a new destination / stopover » page 183
- ▶ **Stop route guidance** - Stops route guidance » page 195

 The following menu is displayed:

- ▶ **Curr. current position** - Store the current vehicle position as the flagged destination » page 187
- ▶ **Routes** - Displays the list of saved routes » page 197
- ▶ **Destinations** - Display the list of stored destinations » page 186
- ▶ **Last destinations** - Display the list of recent destinations to which route guidance was carried out » page 186
- ▶ **Home address** - Route guidance to your home address » page 187

 Search for POIs in categories 

 Map display options » page 190

  Playback control **Media/Radio** (does not apply to vehicles with Infotainment Amundsen and the digital instrument cluster)

 Display for the volume setting of the navigation announcements/repetition of the navigation announcement » page 195

 Navigation settings » page 142





B Change the map display between the digital instrument cluster and the Infotainment screen (applies to vehicles with Infotainment Amundsen and the digital instrument cluster)

Map







Fig. 224
Card description

The following information and function surfaces can be displayed in the map. » Fig. 224

- A** Vehicle position
- B** Route
- C** Function interfaces for card use » page 190
- D** Functional surface of the POI
- E** Functional surface for the POI list
- F** Function surface for displaying a traffic incident » page 201
- G** Information on the maximum permitted speed
-  Destination position
-  Intermediate destination position
-  Destination position **Home address**
-  Favourite position

Information in the status line

-  Street name / street number of the current vehicle position
-  Distance to destination
-  Route to the stopover
-  Estimated travelling time to the destination

- 🕒 Estimated travel time to the stopover
- 🕒 Estimated time of arrival at destination / stopover

additional window

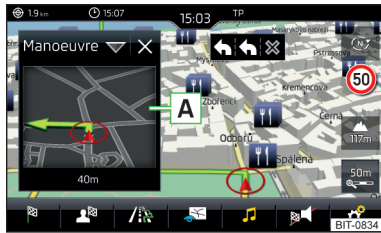

Fig. 225
Split screen

Applies to vehicles with **Infotainment Amundsen and the digital instrument cluster**: when the map display is displayed in the digital instrument cluster, the split screen is always shown and cannot be dimmed.

- To **switch on/off** the main menu *Navigation*, tap on the function surface → **Split screen**.
- To **select content** of the additional window **A** » Fig. 225 tap the function surface Tap and select one of the following menus, depending on the context.
 - **Audio** - Operation of **Radio/Mediaplayback**
 - **Compass** - Displays the current vehicle location in relation to the compass directions
 - **Freq. Routes** - Displays the three most frequently travelled routes (if route guidance is disabled) » [page 195](#)
 - **Manoeuvre** - Display graphical driving recommendations (if route guidance is enabled) » [page 195](#)
 - **Position** - Displays the geographical coordinates of the current vehicle location
 - **Map** - Preview card display (applies to vehicles with Infotainment Columbus, without the digital instrument cluster) » [page 192](#)

Search for destination and enter

Selecting the type of destination search/destination entry

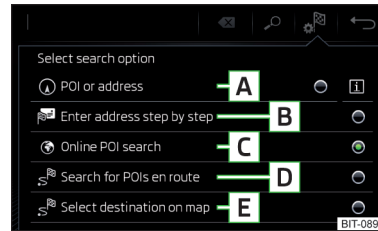

Fig. 226
Selecting the type of destination search/destination entry

- **Route guidance is disabled** - From the *navigation* main menu, the function surface → .
- **Route guidance is enabled** - From the main menu *navigation*, tap on the function surface → **Enter destination** → .

Function surfaces » Fig. 226

- A** Search for a destination or POI (point of interest) by name » [page 183](#)
- B** Destination entry by address » [page 184](#)
- C** Online POI search » [page 183](#)
- D** Search for a point along the route (only works with active route guidance) » [page 183](#)
- E** Destination input via the map point or using the GPS coordinates » [page 185](#)

Search POI destination /

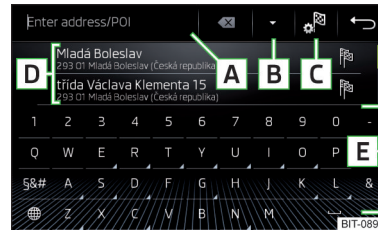

Fig. 227
Menu for the destination search

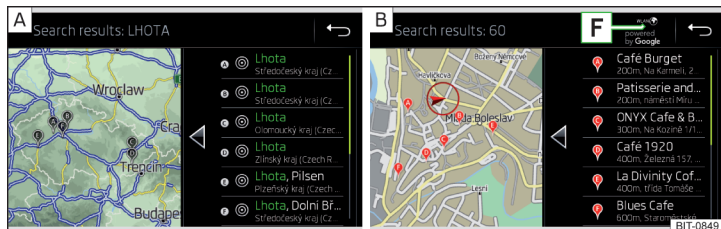

Fig. 228 List of destinations visited: in the navigation data / online

The feature allows a full text search of locations or points of interest (POI) by entering keywords.

Show menu

- › **Route guidance is disabled** - From the *navigation* main menu, the function surface P → P .
- › **Route guidance is enabled** - From the main menu *navigation*, tap on the function surface P → Tap **Enter destination**
- › Then tap the function surface of one of the menu items for the destination search **A**, **C** or **D** » Fig. 226 on page 183.

Function surfaces » Fig. 227 and » Fig. 228

- A** Input line
- B** Depending on the search mode, the following symbols are displayed
 - ∇ - Display the map as well as the list of the destinations listed in the navigation database
 - - Display the map as well as the list of online destinations
- C** P - Select the destination search/destination entry » page 183
- D** List of last destinations (if no character is entered) / List of visited destinations
- E** Keypad
- F** Status of online services

Find destination

› Enter the POI name or the POI category (POI) and, **if required**, the place and street name or house number/postal code.

A list of the destinations found is displayed in area **D** » Fig. 227.

- › Select the desired destination and the destination details will be displayed.
- › **or:** Tap the **B** » Fig. 227 function surface.

A map with the following symbols and a list of the destinations found is displayed.

- P Destinations found in the navigation data » Fig. 228 - **A**.
- P Destinations found online » Fig. 228 - **B**.

- › Select the desired destination and the destination details will be displayed.

Enter destination using the address

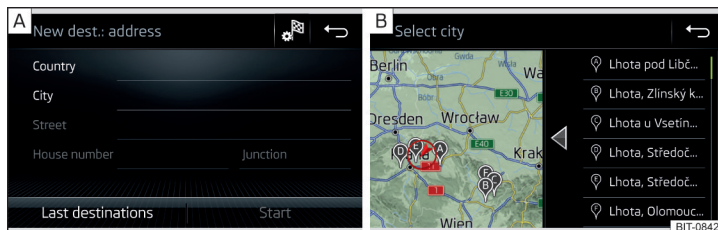

Fig. 229 Enter destination using the address: Main menu / List of visited destinations

Show menu

- › **Route guidance is disabled** - From the *navigation* main menu, the function surface P .
- › **Route guidance is enabled** - From the main menu *navigation*, tap on the function surface P → Tap **Enter destination**
- › Then tap the function surface P → **B** » page 183

Enter destination

- › Enter the destination address and then confirm » Fig. 229 - **A**.
- › Tap the function surface **OK** to see the destination details.

Relevant names (e.g. Place/street names) are offered in the entry line during entry, depending on the context. The location of the proposed destination can be displayed by tapping the function surface **Map**.

Depending on the number of places visited, a map with a list of visited places can be displayed automatically » Fig. 229 - **B**.

The map with the list of visited locations can be accessed manually by tapping the function surface .

Entering a destination via the map point and using GPS coordinates

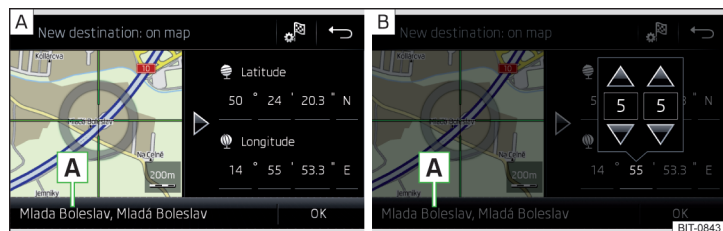







Fig. 230 Enter destination: via the map point / using the GPS coordinates



Show menu

- › **Route guidance is disabled** - From the *navigation* main menu, the function surface .
- › **Route guidance is enabled** - From the main menu *navigation*, tap on the function surface  → Tap **Enter destination**
- › Then tap the function surface  →  » Fig. 226 on page 183.

Enter destination via map point

- › By sliding the screen move the desired destination into the cross-hair
» Fig. 230 - .
- › Tap the function surface  to see the destination details.

Enter destination through GPS coordinates

- › Tap in the values of the GPS coordinates one at a time and adjust » Fig. 230 - .
- › Tap the function surface  to see the destination details.

If information is available about the point entered in the navigation data, then these will be displayed instead of the GPS coordinates (e.g. address  » Fig. 230).

Entering a destination via the map point

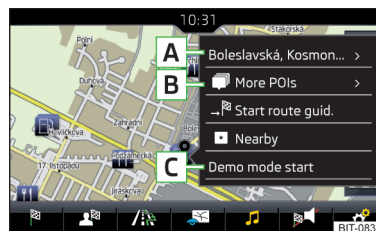











Fig. 231 Menu after tapping the map point

Tap on the map to display the symbol  and a menu with the following menu items (depending on the context) » Fig. 231.

-  Display the destination details » page 193
-  Display the POI details/display the POI list (function surface) 
-  Start route guidance to the selected point
-  Paste the selected point as the next destination in the current route guidance
-  Start route guidance to the favourite
-  Start route guidance to the home address
-  Destination search in the vicinity of the selected point » page 183
-  Define the starting point for demo mode (if it is turned on) » page 194

Find petrol station, restaurant or car park

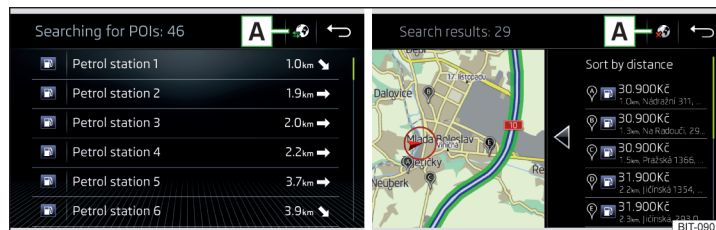

Fig. 232 List of petrol stations visited: in the navigation data / online

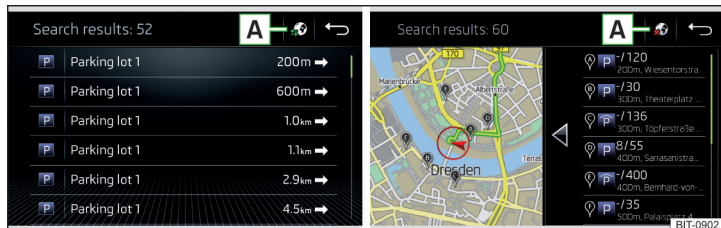

Fig. 233 List of car parks visited: in the navigation data / online

The Infotainment allows you to find petrol stations, restaurants or car parks quickly in the navigation data as well as online.

- › In the *Navigation* main menu, tap the functional surface .
- › The function surface of the desired category button.
- › or: Tap the **MENU** sensor field and then the function surface → or .

Search destination in the navigation data

Depending on the context below a list be examined POIs in the selected category is displayed.

- ▶ **There is no route guidance** - The nearest destinations in a radius of 200 km from the current vehicle position are displayed.
- ▶ **There is a route guidance** - Destinations on the route or near the route are displayed.

Find Target online

When “Infotainment Online” » [page 14](#) services are activated, a list of POIs from the selected category in a radius around the current vehicle position is displayed, regardless of whether or not route guidance is taking place.

After performing destination search, it is possible to switch between the list of visited in the navigation data or online goals by one of the following functional areas on the position **A** » [Fig. 232](#) or. » [Fig. 233](#) is tapped.

- Displays the list of destinations visited in the navigation data.
- Displays list of last destinations

i Note

With function activated → **Fuel options** → **Select preferred fuel station** function activated, the preferred fuel stations are displayed in the first three positions during the fuel station search.

Saved destinations

Last destinations

List of last destinations

- › In the *Navigation* main menu, tap on the function surface → **Last destinations**.

Details of the last destination (not applicable to Infotainment Columbus)

- › In the main *Navigation* menu, tap the **NAV** sensor field.

If route guide is disabled, then the details of the last destination are displayed to where the route guidance was carried out. **If route guidance is enabled**, Then the details of the final destinations are displayed.

Last destinations menu for destination / POI search

In the menu for finding destinations in **D** » [page 183](#), a short list of the most recent destinations is displayed.

Function surfaces in the list of last destinations

Search - Destination search by name (the function surface is displayed with more than 5 entries available)

- > - Display the details of the selected destination » [page 193](#)

target memory

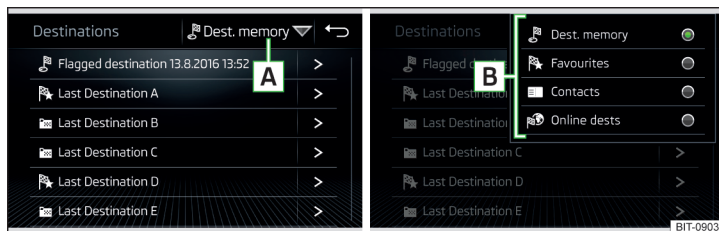













Fig. 234 Select list of stored destinations / categories of saved destinations

List of stored destinations

- › In the *Navigation* main menu, tap on the function surface  → **Destinations**.
- › Tap on function surface  » Fig. 234 and select one of the following categories of saved destinations  » Fig. 234.
 -  All saved destinations
 - ▶  - Flagged destination (vehicle position at the time of storage)
 - ▶  - Stored destination (manually saved destination/destination imported in vCard format)
 - ▶  - Favourite (destination with additional favourite property)
 -  Favourites (the favourite location is shown in the map by the symbol ).
 -  Telephone contact addresses of the connected telephone or the inserted SIM card.
 -  Online destinations created in the user profile on the “ŠKODA Connect Portal” website or in the “ŠKODA Connect” application » [page 189](#)

Function surfaces in the list of stored destinations

- Search** - Destination search by name (the function surface is displayed if there are several entries on the next page of the list)
- > - Display the destination details » [page 193](#)

Store target

- ▶ In the *Navigation* main menu, tap on the function surface  → **Last destinations**.
- ▶ Tap the functional surface > Tap on the desired destination, the destination details are displayed.
- ▶ Tap on the function surface **Store** .
- ▶ Rename the destination if necessary and confirm storage.



“Flagged destination” Save (current vehicle position)

- ▶ In the *Navigation* main menu, tap on the function surface  → **Store** → **Store current position**.
- ▶ By then pressing the function surface **Rename** the flagged destination can be renamed and stored as a destination in the dest. memory.

By storing the next flagged destination, the last flagged destination will be overwritten. To maintain the existing flag destination, this destination must be stored in the Infotainment memory.



Save as a favourite / cancel

It is not possible to store a contact, a vCard or target image as a favourite.

- ▶ In the *Navigation* main menu, tap on the function surface  → **Destinations**.
- ▶ Tap the functional surface  and select the desired list of destinations.

- ▶ Show the destination details by tapping on the function surface > at the desired destination.
- ▶ Tap on the function surface **Edit** .
- ▶ Tap on the function surface **Favourite** .

Delete destination

- ▶ In the *Navigation* main menu, tap on the function surface  → **Destinations**.
- ▶ Tap the functional surface  and select the desired list of destinations.
- ▶ Show the destination details by tapping on the function surface > at the desired destination.
- ▶ Tap the function surface **Edit**.
- ▶ Tap the function surface **Delete** and confirm the deletion.

Home address

Define home address

When your home address is not entered, then proceed as follows.

- › In the *Navigation* main menu, tap on the function surface  → **Home address**.
- › Defining the home address using the current vehicle position or by entering the address.

Change the home address

- › In the *Navigation* main menu, tap on the function surface  → **Manage memory** → **Define home address**.
- › Tap the function surface **Edit** .
- › Edit the home address or set one up using the current vehicle position or by entering the address.

Delete home address

- › In the *Navigation* main menu, tap on the function surface  → **Manage memory** → **Delete user data** → **Home address**.
- › Tap the function surface **Delete** and confirm the deletion.

Introduction to the subject



Fig. 235
MyDestination application on the ŠKODA websites

BIT-0611



Fig. 236
Websites ŠKODA Connect

BIT-0744

Your own destinations can be created using the ŠKODA application "MyDestination", in the user profile on the website "ŠKODA Connect Portal" or in the application "ŠKODA Connect"

By reading the QR code » Fig. 235 or after typing the following address in the web browser, more information on the "MyDestination" application is displayed.

<http://go.skoda.eu/my-destination>

For the "ŠKODA Connect Portal" refer to the website of "ŠKODA Connect". This is carried out by reading the QR code » Fig. 236 or after entering the following address into the web browser.

<http://go.skoda.eu/connectivity>

Goals in vCard format

In the Infotainment memory, a custom destination can be imported in the vCard format (*.vcf) from an SD card or a USB source.

Import

- › Insert the SD card into the external module or connect a USB source with the own destination file.
- › In the *Navigation* main menu, tap on the function surface → **Manage memory** → **Import destinations (SD/USB)**.
- › Select the source and confirm the import.

Route guidance

- › In the *Navigation* main menu, tap on the function surface → **Destinations** → → .
- › Search for and select the desired imported destination.

Delete own destination

- › In the *Navigation* main menu, tap on the function surface → **Destinations** → → .
- › Tap the functional surface > Tap on the desired own destination.
- › In the destination details, tap the function surface **Edit** → **Delete** and confirm the deletion.

In the application "MyDestination" created POI categories

Import / update

- › Insert the SD card into the external module or connect a USB source with the POI categories.
- › In the *Navigation* main menu, tap on the function surface → **Manage memory** → **Update "My POIs" (SD/USB)** Tap.

If there is already the same POI category name in the Infotainment memory, then it will be overwritten during import.

Show POIs in the map

- › In the *Navigation* main menu, tap on function surface → **Map** → **Select categories for POIs** → **My points of interest (Personal POI)**.
- › Select the imported POI category.

Guidance to the POI

- › Tip on the traffic obstruction icon in the map.

There are details of the selected target appears » [page 193](#).

Clear all own POI categories

- › In the *Navigation* main menu, tap on function surface  → **Manage memory** → **Delete "My POIs"**.
- › Tap the function surface **Delete** and confirm the deletion.



In user profile "ŠKODA Connect Portal" created POI categories

Your own POI categories created in the user profile on the website "ŠKODA Connect Portal" can be imported into the Infotainment memory.

The requirement for importing a POI category is that "Infotainment Online" » [page 14](#) services are activated.

Import POI categories

In the *Navigation* main menu, tap on function surface  → **Version information** → **Update (online)**.

› **or:** Tap the  sensor field and then the function surface  → .

A menu for importing/updating the navigation data and POI categories is displayed.

› Tap the functional surface  → **POIs (online services)** → **Retrieve**.

Are new POI categories available, their number and the file size is displayed on the Infotainment.

- › Tap the function surface **Start** to start route guidance.
- › To complete the import, tap the function surface **Next** and confirm the import.

Show POIs in the map

- › In the *Navigation* main menu, tap on function surface  → **Map** → **Select categories for POIs** → **My points of interest (Personal POI)**.
- › Select the imported POI category.

Route guidance to a destination of imported POI category

› Tip on the traffic obstruction icon in the map.

There are details of the selected target appears » [page 193](#),

Clear all own POI categories







- › In the *Navigation* main menu, tap on function surface  → **Manage memory** → **Delete "My POIs"**.
- › Tap the function surface **Delete** and confirm the deletion.

In user profile "ŠKODA Connect Portal" objectives created

The destinations you have created in the user profile on the website "ŠKODA Connect Portal" or in the application "ŠKODA Connect" can be imported to the Infotainment memory.



The requirement for importing the destinations is that "Infotainment Online" » [page 14](#) services are activated.

import goals

- › In the *Navigation* main menu, tap on function surface  → **Destinations** →  → .
- › **or:** Tap the  sensor field and then the function surface  → .
- › Tap on the function surface **Update**.
- › Are new targets available, then confirm the import.

If the user profile on the website "ŠKODA Connect Portal" or in the application "ŠKODA Connect" creates an object and sent to the Infotainment, after switching on the ignition in the Infotainment screen displays a message regarding a new destination with the option to import this displayed.

Guidance to an online destination

- › In the *Navigation* main menu, tap on function surface  → **Destinations** →  → .
- › In the list of online dests to visit and select the desired destination.

Delete Online destinations





- › to delete **all** Online destinations in the main menu *navigation* the function surface  → **Manage memory** → **Delete user data** → **Online destinations**.
- › To delete **one** online destination, go to the *navigation* main menu and tap on function surface  →  →  →  → **Edit** → **Delete**.

Image with GPS coordinates



Fig. 237
Image with GPS coordinates

Infotainment enables guidance to the GPS coordinate data stored in the image.

- ▶ Tap the **MENU** sensor field and then the function surface **Images**.
- ▶ Select the connected source and open the image with GPS coordinates.
- ▶ Tap on the function surface **Fig. 237** Surface in the image, a menu opens with the option to start route guidance.

The image can be obtained from an external device in which GPS coordinates are stored during the imaging process. It is also possible to create and import this in the application "MyDestination" » **Fig. 235** on page 188.

Map

Map display options

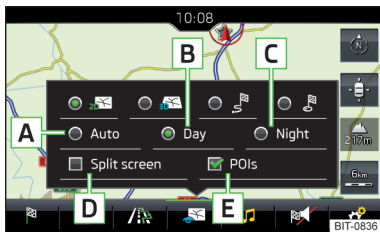







Fig. 238
Map options

- ▶ In the **Navigation** main menu, tap on the functional surface .

The following function surfaces are displayed » **Fig. 238**.

-  2D - Two-dimensional map display
-  3D - Three-dimensional map display
-  Display of the route from the current vehicle location to the destination
-  Presentation of the destination position or the next interim destination in the map (depending on the menu item setting) → **Advanced settings** → **Status line**.)
- A** Automatic map display in day or night mode (depending on the currently active vehicle lighting)
- B** Daytime map display
- C** Night-time map display

- D** Turns the auxiliary window on / off » **page 183** (does not apply to vehicles with Infotainment Amundsen when the map is displayed in the digital instrument cluster)
- E** Switching on / off of the selected POI categories display » **page 185**, *Entering a destination via the map point*

If the map scale of the 2D Map or 3D Map is greater than 10 km, then the map is automatically displayed as 2D and aligned in the direction of north. If the scale is increased beyond this value, then the map is switched back to the original representation.

Map scale

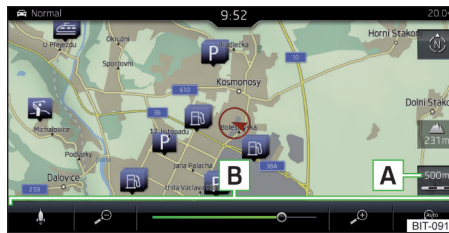

Fig. 239
Function surfaces for changing the map scale: Infotainment Columbus

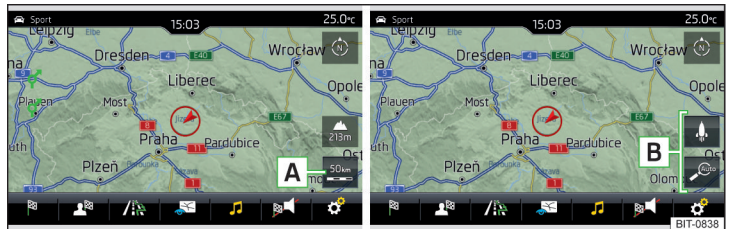



Fig. 240 Function surfaces for changing the map scale: Infotainment Amundsen

It is possible to change the map manually or to turn on the automatic change of scale.

- ▶ Tap on function surface **A** » **Fig. 239** or » **Fig. 240**.

In area **B** » Fig. 239 or » Fig. 240, function surfaces for changing the map scale are displayed.

Types of manual scale change

- ▶ Touching the screen with two fingers and pulling them apart or closing them together.
- ▶ Turn the control knob (not applicable to Infotainment Columbus)
- ▶ Tap the function surface **A** » Fig. 239 and use the slider or tap the function surface  /  in area **B** » Fig. 239 (applies to Columbus Infotainment).

Turn on/off the automatic change of scale

If the automatic scale is active, the map scale will change automatically depending on the type of roads travelled (motorway - smaller map scale / town larger map scale) and from the manoeuvre to be carried out.

- ▶ To **switch on** the automatic scale change, go to the *Navigation* main menu and tap on function surface  → .

Tap the functional surface  is highlighted in green.

The automatic scale is only active as long as the map is centred on the vehicle position (the function surface  is hidden).

- ▶ To **switch off** the automatic scale change, go to the *Navigation* main menu and tap on function surface  → .

Tap the functional surface  is highlighted in white.

The turning off occurs likewise when the map is moved or the map scale is changed manually.

Map view in reduced scale

- ▶ In the *Navigation* main menu, tap on function surface **A** → .

The map scale is reduced for a few seconds and then restored.

Change map orientation

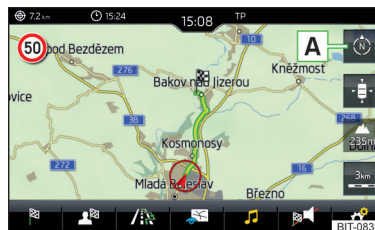





Fig. 241
Change the map orientation

Changing map orientation is possible under the following conditions.

- ✓ The map is in the 2D display.
- ✓ The map is centred (the functional surface  is hidden).
- ✓ The map scale is max. 10 km away.



- ▶ to **Change the map orientation** From the main menu *navigation* the functional surface  **A** » Fig. 241.

The map is oriented to the north

The symbol  the vehicle position rotates, the map and the Polar Star Symbol  do not rotate.

With a larger map scale than 10 km, the map is automatically oriented towards north.

Map oriented to the direction of travel

The map and the Polar Star Symbol  rotate, the vehicle position symbol  does not rotate.

Map alignment

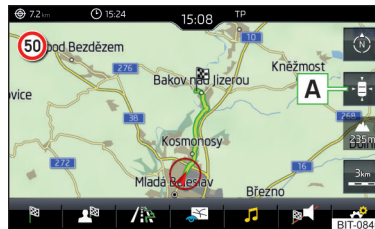

Fig. 242
Map alignment

The moved map can be centred/aligned to the vehicle, destination or route position.

► To **centre the map**, tap on function surface **A** » Fig. 242.

Options for map display in the split screen

Applies to vehicles with Infotainment Columbus, without the digital instrument cluster.

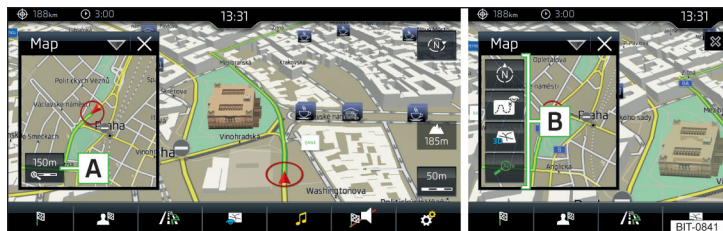

Fig. 243 Map in split screen

► In the split screen, tap on function surface **A** » Fig. 243.

Depending on the context, some of the following function surfaces will be displayed in area **B**.

- ☑ Map display with the route from the current vehicle location to the destination
- 📍 Change the map orientation
- 2D - Two-dimensional map display
- 3D - Three-dimensional map display
- 📏 Turn on/off the automatic change of scale

Map display options in the digital instrument cluster

Applies to vehicles with Infotainment Columbus, with the digital instrument cluster.

The ignition must be switched on for map display in the digital instrument cluster.

Only applies to Infotainment Columbus

The map can be displayed in the digital instrument cluster and in Infotainment at the same time.

The map type shown in the digital instrument cluster can be selected in the *navigation* menu item **☰** → **Map** → **Map view in instrum. cluster**.

The map scale can be adjusted with the dial **A** on the multifunction steering wheel » page 38,

Applies to Infotainment Amundsen

The map can be displayed in the digital instrument cluster or infotainment screen.

► To change the display in the *navigation* main menu, tap function surface **B** » Fig. 223 on page 182.

The map type shown in the digital instrument cluster can be changed in the *navigation* main menu in the menu item **☰**.

Changing the map scale can be carried out in one of the following ways.

- With the function surfaces in Infotainment » page 190.
- By turning the dial **⌚**.
- With the dial **A** on the multifunctional steering wheel » page 38.

POIs display

The Infotainment system offers the possibility of displaying POI symbols on the map on the Infotainment screen.

- To **activate/deactivate the display**, go to the main *Navigation* menu and tap on the function surface **☰** → **POIs**.
- To **select the POIs to be displayed**, go to the main *Navigation* menu and tap on the function surface **☰** → **Map** → **Select categories for POIs** and select the desired categories (max. 10).

Road sign display

Infotainment offers the option of displaying the traffic signs stored in the navigation data or detected by the front camera during guidance on the Infotainment screen **G** » Fig. 224 on page 182.

- To **switch on/off** the road sign display in the main menu *Navigation*, tap the function surface **☰** → **Map** → **Show road signs**.

For some vehicles it is possible to set an **alert when exceeding the permitted speed limit** set by a **road sign**.

▶ Tap the **CAR** sensor field and then the function surface  → **Driver assistance** → **Speed warning**.

For **trailer towing**, we recommend that you activate detection of road signs relevant to trailers.

▶ Tap the **CAR** sensor field and then the function surface  → **Driver assistance** → **Show road signs relevant to trailers**.

Route guidance

Introduction to the subject

A **route** is created by starting route guidance to a destination. Additional **intermediate destinations** can be added to the route.

The route guidance takes place as follows

- ▶ Through graphical driving instructions in the Infotainment display screen and in the display of the instrument cluster.
- ▶ With navigation announcements.

Infotainment tries to allow for continued guidance even if the navigation data is incomplete or there is no data at all for the given area.

The route is recalculated each time if you ignore driving recommendations or change the route.

CAUTION

The nav. announcements provided may vary from the actual situations, e.g. due to out-of-date navigation data.

Destination details

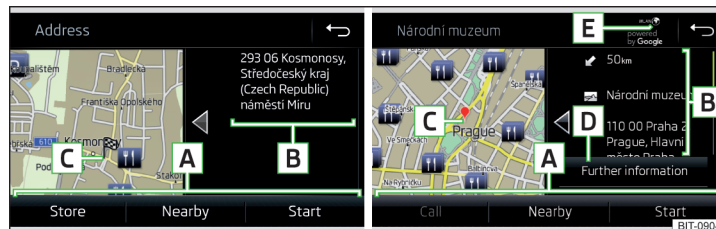

Fig. 244 Details of the: in the navigation data / destination searched for online

The following menu items and information are displayed in the destination details » Fig. 244.

- A** Area with functional surfaces
- B** Detailed destination information
- C** Destination position in the map
- D** Detailed target information (if available)
- E** Status of online services

Display the destination details

The destination details can be displayed in one of the following ways.

- ▶ While entering a destination.
- ▶ By tapping the function surface > in the destination list.
- ▶ By tapping the **NAV** sensor field in the *Navigation* main menu (not applicable to Infotainment Columbus), the details of the last destination are displayed.

Function surfaces

Using functional surfaces in the field **A** the following functions can be performed, depending on the context.

- ▶ Start / Stop route guidance.
- ▶ Searching for a nearby destination » [page 183](#).
- ▶ Setting route options.
- ▶ Store destination.

- ▶ Edit destination (the object can be deleted, renamed or saved).
- ▶ Dial the POI telephone number (if Infotainment is connected to a telephone» [page 163, Pairing and connecting](#)).

Route calculation and start route guidance

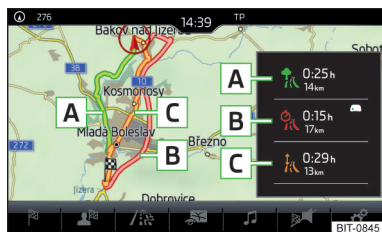

Fig. 245
Alternative routes

Route calculation is done on the basis of the set route options. The route options can be set: → **Route options**.

Alternative routes

With selection of alternative routes turned on, the following menu is displayed after the calculation of a new route » [Fig. 245](#).

- A** Calculate the most economical route with shortest travelling time and distance travelled – the route is highlighted in green
- B** Calculate the fastest route to the destination, even if a detour is necessary - the route is highlighted in red
- C** Calculate the shortest route to the destination, even if a longer travelling time is required - the route is highlighted in orange

In the functional surfaces of the alternative routes, information on the route length estimated travel time and the following symbols are displayed (applies to the Infotainment Columbus).

- Use of a toll motorway
- Use of a train / ferry
- Using a tunnel
- Use of a toll road
- Using a vignette duty road

It is possible to select an already calculated alternative route before the calculation of the remaining routes is completed.

Selecting the type of route will start the route guidance.

If no route selection is made within 30 s after the calculation of all routes, the route guidance is automatically started according to the preferred route type.

Route calculation for the trailer

When driving with a trailer or any other accessory connected to the trailer socket, we recommend that you switch on the trailer recognition, if necessary to set the maximum speed for towing a trailer.

- ▶ For calculating the route for towing a trailer, tap the functional surface in the main *navigation* menu → **Route options** → .
- ▶ To set the maximum speed for towing a trailer, tap the **CAR** sensor field and then the function surface → **Driver assistance** → **Trailer recognition** → **Maximum speed for trailer**.

Demo mode

The Demo mode provides a travel simulation to the entered destination. The function offers the chance to travel through the calculated route "virtually".

When the Demo mode is turned on, a menu for route guidance in the Demo mode or in normal operation is displayed before the start of route guidance.

- ▶ To **switch on/off** in the main menu *Navigation*, tap the function surface → **Advanced settings** → **Demo mode**.

When the demoMode is switched on, the route starting point can be defined.

- ▶ In the *Navigation* main menu, tap the functional surface Tap → **Advanced settings** → **Define demo mode starting point**.
- ▶ Define the starting point by entering the address or the current vehicle position.
- ▶ The demo mode starting point can also be set provided demo mode is turned on by tapping on the desired map location and selecting the menu item **Start Demo Mode** » [page 185, Entering a destination via the map point](#).

Graphical driving recommendations

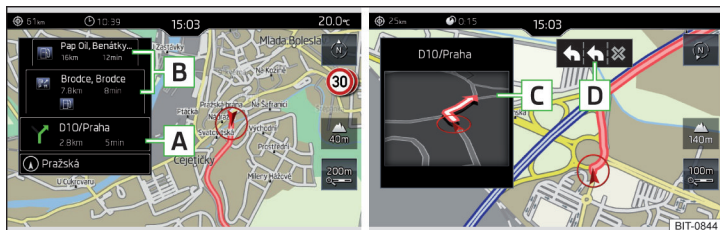

Fig. 246 Driving recommendations / travel recommendation detail

The display of the graphical driving recommendations is carried out in the split screen **Manoeuvre** as well as the display of the instrument cluster.

In the split screen **Manoeuvre** the following driving recommendations are shown » Fig. 246.

- A** Street name / street number of the current vehicle position
- B** Driving recommendations with street names / road numbers, with the route and the travel time to the manoeuvre place
- C** Details of driving recommendation (is displayed near the manoeuvre)
- D** Lane guidance

In the split screen **Manoeuvre**, Infotainment also announces TMC traffic obstructions and on motorways, car parks, petrol stations or restaurants.

Speed limits



With activated function  → **Advanced settings** → **Note: National border crossed**, display the country-specific speed limits when crossing international borders.

These speed limits can be displayed by tapping the function surface  → **Top speed** in the main menu *navigation*.

Nav. announcements

Infotainment issues nav. announcements during route guidance.

The navigation announcements are generated by Infotainment. The flawless clarity of the message (e.g., road or city name) cannot always be guaranteed.

The last navigation announcement can be repeated in the main *Navigation* menu by tapping on the function surface  → .

The timing of the navigation message is dependent on the type of road and on the driving speed.

The type of nav. announcements can be set:  → **Navigation announcements**.

i Note

Route guidance on the most frequently travelled route takes place without navigation announcements.

Most common routes

The most frequently travelled routes are automatically saved by Infotainment. Of these, up to 3 routes can be offered, which best match the current time, day of the week as well as the vehicle position.

A route guidance to one of the most travelled routes can be started as long as **no route guidance** takes place.

- To display the menu with the most frequently travelled routes, tap on function surface **Freq. in the split screen routes** → **Show on map**.
- Select the desired route.

Then a selected route is calculated and the route guidance starts.

The menu display in the split can be turned on/off in the main menu *navigation* by tapping the function surface  → **Route options** → **Freq. Routes**.

The stored most frequent routes can be deleted in the main menu *navigation* by tapping the functional surface  → **Manage memory** → **Delete user data** → **Freq. Routes**.

i Note

Route guidance on the most frequently travelled route takes place without navigation announcements.

Finish route guidance

The route guidance can be finished in one of the following ways.

- The final destination is reached.
- In the main menu *Navigation* by tapping the functional surface  → **Stop route guidance**.

- ▶ By turning off the ignition for longer than 120 minutes.

Abort route guidance

If the ignition is switched off and on again, then the route guidance is continued depending on the stop time in one of the following ways.

- ▶ Within 15 min. - route guidance is continued taking into account the calculated route.
- ▶ From 15 min to 120 min - after confirming the message on the infotainment screen, the route guidance continues, taking into account the calculated route.
- ▶ After 120 min - the route guidance is cancelled.

Route

Route schedule

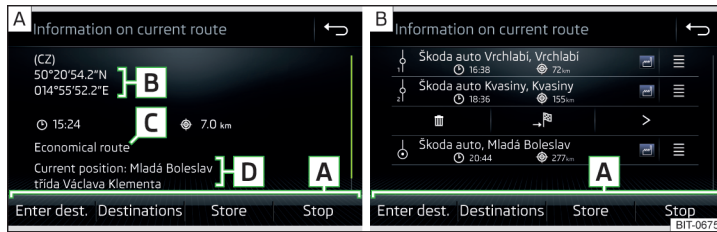

Fig. 247 Route details: a route destination / several route destinations

During route guidance, the **Route details** (Information about the current route) can be displayed.

- ▶ In the *Navigation* main menu, tap the functional surface → **Route details**.

A route destination

In the route plan, the following information is displayed at the destination» Fig. 247 - [A].

- [A] Area with functional surfaces
- [B] Destination information
- ⌚/🕒 Estimated time of arrival at destination / remaining driving time to destination

- 📍 Remaining distance to the destination
- [C] Chosen route type (economic, fastest, shortest)
- [D] Current vehicle position (address / GPS coordinates)

The display of the arrival time or the remaining driving time can be adjusted as follows.

- ▶ In the *Navigation* main menu, tap on the functional surface → **Advanced settings** → **Time display**.

Several route destinations

In the route plan, the following information is displayed at the respective destinations» Fig. 247 - [B].

- [A] Area with functional surfaces
- ⌚ Stopover (with sequential number)
- 📍 Final destination
- ⌚ Estimated time of arrival at destination / stopover
- 📍 Driving distance to destination / stopover
- ☰ Substitution of destinations among themselves
- 🗑️ Delete the destination
- ➡️ Continuation of the route guidance from the selected target (previous waypoints are skipped)
- > Display the destination details » [page 193](#)

Insert destination into the route

- ▶ In the area [A], tap on the function surface **Enter destination** and enter a new destination.
- ▶ **or:** Tap on the area [A] the function surface **destinations** and select an object in the list of stored destinations.

Each additional destination is added to the list as the first subsequent destination route.

Change positions of destinations with each other

- ▶ The relevant function surface and move the destination to the desired position.

With destinations on the route already reached, the note **Destination reached** is displayed below the destination name. It is not possible to change the position of these destinations with each other.

Store route

- ▶ In the area **A**, tap the functional surface **Save**.
- ▶ Save the edited route as a new route or replace the existing saved route.

The route is saved in the route list» [page 197](#).

Stop route guidance

- ▶ In the area **A**, tap the functional surface **Stop**.

Route change in the map

Only valid for *Infotainment Columbus*.

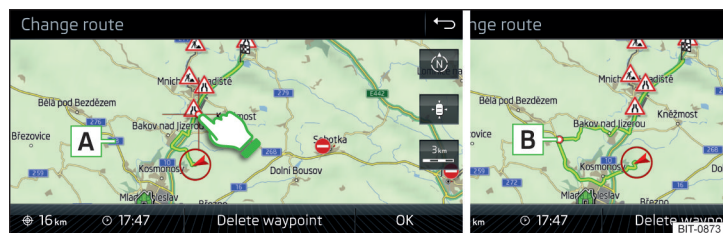

Fig. 248 Route change in the map / route transit point

A route in which there are no intermediate targets can be changed during route guidance by inserting a transit point.

Add a transit point

- ▶ In the *Navigation* main menu, tap on the function surface **Change route in map**.
- ▶ Touch the screen in the route field and move the cross-point to the desired location on the map, e.g. **A**, move » [Fig. 248](#)).

The transit point **B** is added to the route » [Fig. 248](#).

- ▶ Tap on the function surface **OK**.

Then a new route is calculated and route guidance starts.

Customise transit point

- ▶ In the *Navigation* main menu, tap on the function surface **Change route in map**.
- ▶ Touch the transit point **B** and move to a different location on the map.
- ▶ Tap on the function surface **OK**.

Then a new route is calculated and route guidance starts.

Remove transit point

- ▶ In the *Navigation* main menu, tap on the functional surface **Change route in map**.
- ▶ Tap on function surface **Delete waypoint**.
- ▶ Tap on the function surface **OK**.

Then a new route is calculated and route guidance starts.

route list

In the route list, it is possible to create routes, save, delete, or start navigation.

New route

- ▶ In the *Navigation* main menu, tap on the function surface **Routes** → **New route**.

Insert a route destination in one of the following ways.

- ▶ Tap on the function surface **Enter destination** and enter a new destination.
- ▶ **or:** Tap on the function surface **Destinations** and select a destination from the list of stored destinations.
- ▶ To save the created route, tap the functional surface **Store**.
- ▶ Tap the functional surface **Start** to start route guidance.

route import



A prerequisite for importing the route is that “*Infotainment Online*” » [page 14](#) services are activated.

A route that has been created in the user profile on the “*ŠKODA Connect Portal*” website and sent to the *Infotainment* system can be imported into the *Infotainment* memory even **before switching on the ignition**.

If the route was created when the ignition was switched on and sent to *Infotainment*, *Infotainment* is not imported until after switching off (for at least 15 minutes) and after switching the ignition back on again.

- ▶ Switch on the ignition. When a new route is available, a message regarding the option to import this route appears in the *Infotainment* screen **automatically**.

If the user opts not to import the route immediately, the route can be imported later **manually** as follows.

- › In the *Navigation* main menu, tap on function surface  → **Routes Tap** to check if a new route is available.
- › **or:** Tap the **(MENU)** sensor field and then the function surface  → .
- › The function surface **import routes Tap**.

If a new route available, then a message is displayed on the Infotainment.

- › Tap the function surface **Retrieve** to start route guidance.

After being successfully imported, the route is displayed in the list of saved routes.

Managing saved routes

- › In the *Navigation* main menu, tap on the functional surface  → **routes**.
- › Choose the desired route, and then select one of the following functions.

Delete Clear saved route

Edit - Edit the route » [page 196, Route schedule](#)

Start - Calculate route and start route guidance » [page 194, Route calculation and start route guidance](#)

Waypoint mode

Introduction to the subject

Only valid for Infotainment Columbus.

This mode is suitable for off-road navigation or for areas where maps are not available.

Infotainment allows the recording of waypoint tours driven using automatic of manually entered waypoints.

Then there is the option to start route guidance to the stored waypoint tour or to save the waypoint tour on the SD card.

Main menu

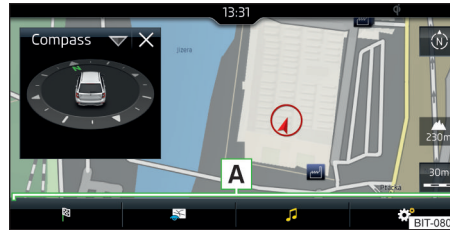

Fig. 249
Waypoint mode: Main menu

- › In the *Navigation* main menu, tap the functional surface  → **Waypoint mode**.

The main menu is displayed» [Fig. 249](#).

Any **ongoing route guidance** is terminated after the selection of this **waypoint mode** menu.

Description of the function interfaces [A](#) » [Fig. 249](#)

 Context-dependent:

- ▶ **No route guidance is taking place** - Start recording a waypoint tour/display saved waypoint tour management/exit menu
- ▶ **A waypoint tour is being recorded** - Stop recording a waypoint tour/manually adjust waypoint/exit menu
- ▶ **Route guidance is taking place** - Stop route guidance/skip the next waypoint/exit menu

 Setting the map display / show / hide the split screen / switch on / off the display of POIs on the map

 Operation of **Radio/Mediaplayback**

 Setting *Navigation* is not available in the **Waypoint mode** menu

Record waypoints

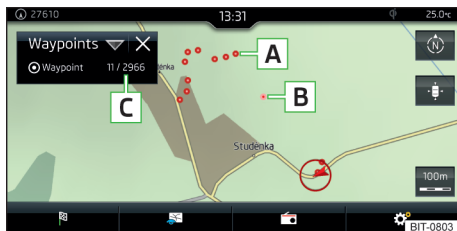

Fig. 250
Recording a waypoint
tour

Start recording a waypoint tour

► In the **Waypoint mode** main menu, tap on the function surface → **Record waypoint tour**.

Select one of the following recording types.

- **Select on map** - Enter destination on the map and start recording waypoints
- **Start recording** - Start recording waypoints without entering a destination

Recording a waypoint tour

After starting the recording of a waypoint tour, the following contextual information may be displayed » Fig. 250.

- A** Automatically set waypoints
- B** Manually set waypoints
- C** Split screen **Waypoints** with the number of already set waypoints / maximum number of waypoints

Add waypoint manually

► In the **Waypoint mode** main menu, tap on function surface → **Add waypoint manually**.

Stop recording

► In the **Waypoint mode** main menu, tap on the function surface → **Stop recording**.

The recording also stops when the **waypoint mode** menu is exited.

The recorded waypoints are merged to a waypoint tour and stored in the waypoint memory after completion of the recording.

The recording cannot be continued once it has been stopped. A new recording must be started.

Guide along a saved waypoint tour

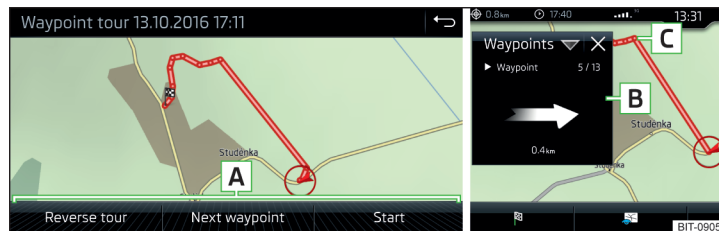

Fig. 251 Display a waypoint / guide along a waypoint tour

Start guidance

► In the **Waypoint mode** main menu, tap on the function surface → **Waypoint memory**.

- Select the desired route from the displayed list.
- Tap on the function surface .
- Select one of the following menus **A** » Fig. 251.

- **Reverse tour** - Reverse the order of waypoints (suitable for guiding along a waypoint tour in the reverse direction)
- **Next. Waypoint.** - Skip to the next waypoint
- **Start** - starts route guidance

Route guidance

During the guidance along a waypoint tour, no nav. announcements are made by Infotainment.

When driving along the waypoint tour shown, follow as closely as possible the information shown on the Infotainment screen.

While driving along a waypoint tour, the split screen shows the **Waypoints** and the direction to drive as well as the distance to the next waypoint, the sequence number of the next waypoint and the total number of waypoints **B** » Fig. 251.

The waypoint tour from the vehicle position to the next waypoint “reduces” continuously while driving “ ” **C** » Fig. 251.

If you drive past but very close to the next waypoint, the route guidance will continue with the subsequent waypoint.

If you drive past a waypoint and this does “not disappear” from the waypoint tour (e.g. because the distance to this waypoint is too large), then there is the option to “skip” over this waypoint and continue the guidance to the next waypoint.

► In the **Waypoint mode** main menu, tap on function surface  → **Skip waypoint**.

Stop route guidance

► In the **Waypoint mode** main menu, tap on function surface  → **Stop route guidance**.



The guidance also stops when **waypoint mode** is exited.

Manage waypoint tour memory

► to **display a list of saved and imported waypoint tours**, from main menu **Waypoint mode**, tap the function surface  → **Waypoint memory**.

The name of the waypoint tour, the date and time of storage and the number of waypoints appears in the function surface for the waypoint tour.

► Choose the desired waypoint tour, and then select one of the following menu items.

-  Store the waypoint tour on the SD card
-  Delete the waypoint tour
-  Rename the waypoint tour
- > Display the waypoint tour » [Fig. 251 on page 199](#)

Import waypoint tour from the SD card

► In the **Waypoint mode** main menu, tap on the function surface  → **Waypoint memory** → **Import**.

► Select the source of the waypoint tour recording and confirm the import.

Traffic reports

List of traffic reports

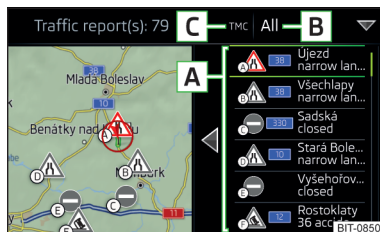







Fig. 252
List of traffic reports

The Infotainment system enables the reception of traffic reports, which include information regarding traffic congestion, using TMC (Traffic Message Channel) or online (when “Infotainment Online” » [page 14](#) services are activated).

ŠKODA AUTO does not accept responsibility for the availability, content, up-to-dateness or evaluation of TMC traffic reports or other data provided by third parties. ŠKODA AUTO is not entitled to examine or adapt this data in any way. The data can only be edited by Infotainment in areas where it is available.

► To **display the list of traffic reports**, tap on the  sensor field and then tap the function surface .

In the list of traffic messages and the map, a max. of 6 messages are displayed, that are provided with a letter and a traffic obstruction symbol (e.g. , , ) [A](#) » [Fig. 252](#).

At present on the route traffic information is taken by using a nav. announcement.

Source of Traffic Information

On the position [C](#) » [Fig. 252](#) can the following symbols are displayed.

TMC TMC Traffic Information (with strikethrough icon, the Infotainment is out of range of any traffic information provider)

 Online traffic information



Display options

- ▶ **Route guidance is disabled** - All traffic messages are displayed.
- ▶ **Route guidance is taking place** - After tapping function surface **B** » Fig. 252 in the displayed menu, you can select all traffic messages by tapping the function surface **All areas**, or you can select only the traffic messages present on the route by tapping the function surface **Route**.

A traffic report may contain some of the following information.

- ▶ Symbol of the traffic obstruction
- ▶ Number of roads affected
- ▶ Name of the location in question
- ▶ Description of the traffic obstruction

The importance of a traffic obstruction is distinguished in colour by a TMC message

The symbol for traffic obstruction (e.g. , , ) precedes the obstruction and the length of the obstruction is shown in the map on the right along the route.

Depending on the context, the symbol for the obstruction is displayed in one of the following ways.

No route guidance is carried out

- ▶ **Red** - All traffic obstructions

Route guidance takes place

- ▶ **Gray** - The traffic obstruction is not on the route
- ▶ **Red** - The traffic obstruction is on the route, the route will not be recalculated and the route passes through the traffic obstruction
- ▶ **Orange** - The traffic obstruction is on the route, the route is recalculated and an alternative route is available

Distinguish the importance of a TMC message traffic obstruction using colour

The colour differentiation of traffic conditions on the provider of the online traffic reports depends.

To change the map orientation, go to the *Navigation* main menu and tap on function surface  → **Map** → **Traffic flow settings**.

Update

The list of traffic reports will be automatically updated by Infotainment on a continuous basis.

Detail of the traffic report

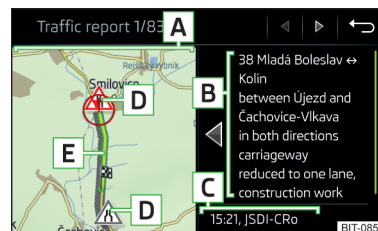

Fig. 253
Detail of the traffic report

The details of the traffic message depends on the source of the traffic message.

- ▶ To **display** this, select the desired traffic report from the list of traffic reports.
- ▶ **or:** Tap on the traffic obstruction icon in the map.

Depending on the context, the following information and functional surfaces are displayed » Fig. 253.

- A** Map of the affected location
- B** Description of the traffic obstruction
- C** Reception timing and information relating to the traffic report provider (if "ŠKODA Connect" is the provider, it is an online traffic report)
- D** Symbol of the traffic obstruction
- E** Length of the traffic obstruction

Dynamic route

Infotainment enables an evaluation of the traffic reports received during the route guidance. In fulfilling the following conditions a bypass route is calculated, and the appropriate announcement is issued.

- ✓ The dynamic route function is turned on.
- ✓ The traffic congestion included in the traffic information is on the route.
- ✓ The traffic obstruction will be evaluated by Infotainment as of great importance.

- ▶ To **switch on/off** in the main menu *Navigation*, tap on the function surface  → **Route options** → **Dynamic route**.

Entering/removing a traffic obstruction on the route manually

If a traffic obstruction is detected during route guidance (e.g. traffic jam), this traffic obstruction be manually entered into the route.

After entering, Infotainment calculates and provides an alternative route.

Enter traffic obstruction

- In the *Navigation* main menu, tap the function surface  → **Congestion ahead**.
- Adjust the length of the traffic obstruction.

The traffic obstruction will be displayed in red in the map to the right along the route.

Remove traffic obstruction

The traffic obstruction is removed from the route after completion of the route guidance or can manually be removed as follows.

- In the *Navigation* main menu, tap the function surface  → **Delete "congestion ahead"**.



vehicle systems

CAR - Vehicle settings

Introduction to the subject

In the menu CAR travel data and information displayed on the vehicle and some vehicle systems can be set.

Reset to factory settings

You can reset to factory settings in the infotainment system in menu  /  → **Factory settings** menu.

Note

Settings relating to the vehicle systems can only be made when the ignition is switched on.

Main menu





Fig. 254
Function surfaces in the main menu

- Tap on the button/sensor field  →  to display the main menu with the following function surfaces » [Fig. 254](#).

 Selecting the following menu points

- ▶ **Dig. Instrument panel**
- ▶ **Sport** (applies to Infotainment Columbus, Amundsen)
- ▶ **Convenience consumers**
- ▶ **Driving data**
- ▶ **DriveGreen**
- ▶ **Vehicle status**

 /  Operating playback - Radio / Media

-  Depending on the vehicle equipment with manual air conditioning: Setting the auxiliary heating and ventilation / operating the heated wind-screen
-  Operation of the steering wheel heating
-  Vehicle system settings

Depending on equipment fitted, it is possible to switch the ignition on/off and start/stop the engine with the **key in the ignition** or using the **starter button**.

WARNING

- Never switch off the engine before the vehicle is stationary – risk of accident!
- The ignition must always be switched during the journey when the engine is idling. Otherwise, the steering may lock - danger of an accident!
- Do not withdraw the ignition key from the ignition lock until the vehicle has come to a stop » [page 210, Parking](#). Otherwise, the steering may lock - danger of an accident!
- Never leave the vehicle unattended with the engine running - there is a risk of theft, accident etc.!
- Never run the engine in an enclosed space (e.g. in garages) - there is the danger of poisoning and death!

CAUTION

- Only start the engine when the engine and the vehicle are stationary - there is a danger of starter and engine damage!
- Do not push-start the engine – there is a risk of damaging the engine and the catalytic converter! The battery from another vehicle can be used as a push-start aid.
- On vehicles with the starter button, pay attention to where the key is located. The system can recognize the valid key, even if it has been accidentally left on the vehicle roof - there is danger of loss or damage to the key!

Note

Do not warm up the engine while the vehicle is stationary. If possible, start your journey as soon as the engine has started. The engine will reach its operating temperature faster.

 **Read and observe  and  on page 204 first.**

The electronic immobiliser (hereinafter referred to as immobiliser) makes it more difficult for someone to attempt to steal or use your vehicle without authorisation.

Immobilizer

The immobilizer allows the engine to be started only with the original car key.

Malfunction of the immobilizer

If the immobiliser in the key fails, it is not possible to start the engine. A message appears in the display of the instrument cluster to explain that the immobiliser is active.

To start, use the other vehicle key or seek help from a specialist garage.

Steering lock - lock

- › On vehicles with **ignition lock**, remove the key and turn the steering wheel until the steering lock engages.
- › On vehicles with a **starter button**, switch off the ignition and open the driver's door. If the driver's door is opened and the ignition is switched off afterwards, the steering is only locked automatically after the vehicle has been locked.

Steering lock - unlock

- › On vehicles with **ignition lock**, insert the key into the ignition and turn on the ignition. If this is not possible, move the steering wheel slightly back and forth and thereby unlock the steering lock.
- › On vehicles with **starter button**, get into the car and close the driver's door. Under certain circumstances, the steering lock can be unlocked only when the ignition is switched on or the engine is started.

WARNING

Never let the vehicle roll with locked steering lock - there is a risk of accident!

Switching the ignition on/off

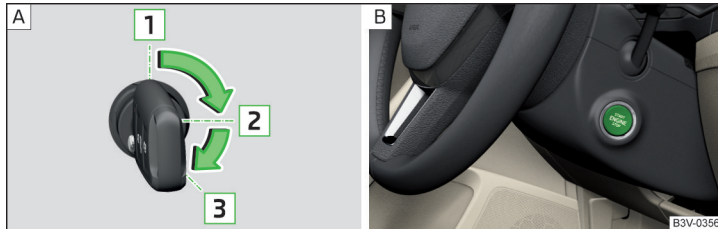

Fig. 255 Positions of the vehicle key in the ignition lock / starter button

📖 Read and observe **!** and **!** on page 204 first.

Positions of the vehicle key in the ignition lock » Fig. 255 - **A**

- 1** Ignition switched off, engine switched off
- 2** Ignition switched on
- 3** Starting engine

Switching on /off ignition in vehicles with starter button

➤ Press the » Fig. 255 - **B** button, the ignition is turned on / off.

On vehicles with **manual transmission** the pedal must not be depressed to switch on / off the ignition, otherwise the engine will start.

On vehicles with **automatic transmission**, the brake pedal must not be depressed to switch on / off the ignition, otherwise the engine will start.

Starting engine / Stopping

📖 Read and observe **!** and **!** on page 204 first.

Before starting the engine

- Switch on the parking brake.
- For vehicles with **manual transmission**, shift gear stick to neutral, depress the clutch pedal and hold it there until the engine starts.
- For vehicles with **automatic transmission**, place the selector lever in position **P** or **N** and » **!** depress the brake pedal until the engine starts.

Starting the engine

➤ On vehicles with **Ignition lock**, turn the key to position **3** and the engine starts » Fig. 255 on page 205 **A**. Release the key, the engine will start automatically.

If the engine does not start within 10 seconds, turn the key to position **1**. Repeat the starting process after 30 seconds.

➤ On vehicles with **starter button**, press the button briefly » Fig. 255 on page 205 - **B**, the motor will start automatically.

In vehicles with **diesel engines**, the glow plug warning lights  up after the ignition is switched on. The engine can be started after the indicator light goes out.

Stopping the engine

➤ Stopping the vehicle.

➤ On vehicles with **ignition lock**, turn the key to position **1** » Fig. 255 on page 205 **A**.

➤ On vehicles with **starter button**, press the button » Fig. 255 on page 205 - **B**. The engine and the ignition will be switched off simultaneously.

For vehicles with automatic transmission, the ignition key can only be removed if the selector lever is in position **P** (this only applies to a few countries).

Do not switch the engine off immediately at the end of your journey after the engine has been running for a prolonged period at high loads. Leave it to run at an idling speed for about 1 minute. This prevents any possible accumulation of heat when the engine is switched off.

Emergency shutdown of the engine in vehicles with starter button

The system is equipped with a protective device against accidental switching off, the engine can only be shut off while driving in the event of an emergency.

➤ Keep the knob pressed » Fig. 255 on page 205 - **B** or press it twice within 1 second.

After the emergency stop of the engine, the steering lock will remain unlocked.

! CAUTION

When the outdoor temperature is below -10°C , the selector lever when starting must always be in **P** mode. ▶

i Note

- The engine running noises may be louder at first for a short time after starting the cold engine.
- You should not switch on any major electrical components during the heating period, otherwise the vehicle battery will be drained unnecessarily.
- After switching off the ignition, the radiator fan may intermittently continue to run for approx. 10 minutes (also continuously).

Problems with the engine start - vehicles with starter button



Fig. 256
Engine start - hold key on button

 Read and observe  and  on page 204 first.

If no engine start is possible and the display of the instrument cluster shows a message that the key could not be detected by the system or there is a system fault, then try to start the engine as follows.

- ▶ Push the starter button and then hold the key with the back of it on the button » Fig. 256.

If the engine does not start, the help of a specialist garage is required.

! CAUTION

The key may not be detected by the system if the battery in the key is running out of charge or the signal fails.

START-STOPsystem

Introduction

The START-STOPsystem (hereinafter referred to as the system) reduces CO₂emissions and harmful emissions, and saves fuel.

If the system determine that the engine is not needed when the vehicle stops or is at a standstill (e.g. at the traffic lights), it turns off the engine and starts it again when moving off.

The system function depends on many factors. Some of them are down to the driver, while others are systemic and can neither be influenced nor identified.

For this reason, the system may react differently in situations which seem identical from the driver's perspective.

The system is automatically activated **every** time the ignition is switched on (even when it has previously been manually deactivated with the  button).

i Note

If the engine has stopped due to the system, the ignition remains switched on.

Operation

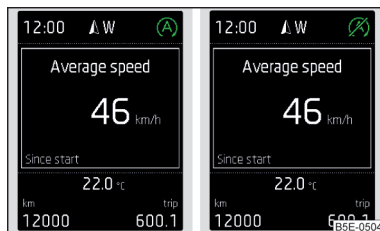

Fig. 257
Display

Vehicles with manual transmission

The engine is automatically **switched off** as soon as the vehicle comes to a halt, the shift lever is moved into neutral and the clutch pedal is released.

The engine is automatically **started** as soon as the clutch pedal is depressed.

Vehicles with automatic transmission

The engine is automatically **switched off** as soon as the vehicle comes to a halt and the brake pedal is operated.

The engine is automatically **started** as soon as the accelerator pedal is depressed or the brake pedal is released (with deactivated Auto Hold function). ▶

Requirements for the system to function correctly

The following conditions must be met for the system to function correctly.

- ✓ The driver's door is closed.
- ✓ The driver has fastened the seat belt.
- ✓ The driving speed was higher than 4 km/h after the last stop.

System status



The system status is shown in the display when the vehicle comes to a halt » Fig. 257.

- (A) The engine is switched off automatically; when moving off, the ignition process will be initiated automatically.
- (A) The engine is not switched off automatically.

When stopping, the engine will not switch off for the following reasons, among others.

- ▶ The engine temperature for the proper function of the system has not yet been reached.
- ▶ The charge state of the vehicle battery is too low.
- ▶ The current consumption is too high.
- ▶ High air conditioning or heating output (high blower speed, big difference between the desired and actual interior temperature).

If the engine is shut down automatically and the system detects that the engine is required, such as when the brake pedal is pressed repeatedly, then the system automatically starts the engine.

More information about the current system status can be displayed in the Infotainment screen in menu **CAR** /  →  → **display Vehicle status**.

If there is a **system fault**, the following message will appear in the display of the instrument cluster. Seek help from a specialist garage.

i Note

- If the driver's seat belt is removed for more than approx. 30 seconds or the driver's door is opened during automatic stop mode, the engine will have to be started manually.
- No automatic engine shut-down takes place when a vehicle with **automatic transmission** is moving at low speed (e.g. during a traffic jam) and remains stationary after pressing the brake pedal lightly. Automatic engine shut-down takes place if you press the brake pedal down with more force.
- For vehicles with **automatic transmission** there is no automatic engine shut-down when the system detects a manoeuvring action due to a large steering angle.

Manually disable / enable system



Fig. 258
Button for the START-STOP system

▶ To **deactivate/activate**, press the  button » Fig. 258.

When the system is deactivated, the symbol  illuminates in the button.

If the system is deactivated, it will be reactivated automatically after the ignition has been switched off and on.

i Note

If the system is deactivated when the engine is turned off automatically, then the automatic start process takes place.

Brakes and Parking

Introduction

The **wear** of the brake pads is dependent on the operating conditions and driving style. Under difficult conditions (e.g. urban, sporty driving style) the condition of the brakes should also be checked by a specialist garage between the service intervals.

The performance of the brakes can be delayed if the brakes are **damp, iced up in winter or if covered in a layer of salt**. The brakes are cleaned and dried by applying the brakes several times » **!**.

Corrosion on the brake discs and dirt on the brake pads occur if the vehicle has been parked for a long period and if you do not make much use of the braking system. The brakes are cleaned by applying the brakes several times » **!**.

Before travelling a **long distance with a steep gradient**, reduce speed and shift into the next lowest gear. As a result, the braking effect of the engine will be used, reducing the load on the brakes. If you do have to brake, this should be carried out at intervals.

Emergency braking display - when an emergency braking is performed, the automatic flashing of the brake lights are used to alert the traffic behind.

New brake pads must first be “worn in” because these do not initially have the best possible braking effect. Drive especially carefully for the first 200 km or so.

A too low **brake fluid level** can cause **faults in the braking system**, the warning light **(P)** illuminates in the instrument cluster » [page 40](#), **(P) Brake system**. If the warning light does not illuminate and an extended stopping distance is required, then driving should be adapted according to the unknown cause of fault and restricted braking effect - seek the assistance of a specialist garage immediately.

The **brake booster** increases the pressure generated with the brake pedal. The brake booster only operates when the engine is running.

! WARNING

- Greater physical effort is required for braking when the engine is switched off – risk of accident!
- During the braking procedure on a vehicle with manual transmission, when the vehicle is in gear and at low revs, press the clutch pedal. Otherwise, the functionality of the brake system may be impaired – risk of accident!
- Do not press the brake pedal if braking is now required. This causes the brakes to overheat and can also result in a longer braking distance and excessive wear - risk of accident!
- Braking for the purpose of drying and cleaning the brake discs should be carried out only if the traffic conditions permit. Do not place any other road users in jeopardy.
- Recommendations for new brake pads have to be observed.
- When stopping and parking, the parking brake should always be on, otherwise the vehicle could move off - there is the risk of an accident!
- If a front spoiler, full wheel trim, etc. is mounted retrospectively, it must be ensured that the air supply to the front wheel brakes is not reduced. Otherwise, the functionality of the brake system may be impaired – risk of accident!

Electric parking brake



Fig. 259
Parking brake button



Fig. 260 Parking brake operation

📖 **Read and observe** **!** on page 208 first.

The electric parking brake (hereinafter referred to as a parking brake) replaces the handbrake. This secures the vehicle when stopping and parking against unwanted movement.

The parking brake can be used when the ignition is on or off.

Switching on

➤ Pull the **(P)** button in the direction of arrow **1** » Fig. 260 and hold until the **(P)** symbol in the button and warning light **(P)** illuminating the instrument cluster.

Automatic shut-off

The parking brake switches off automatically when starting, as long as the driver's door is closed and the driver has fastened the seat belt.

Should the vehicle start to roll away backwards when starting on an uphill slope, step on the accelerator or switch on the parking brake.

Turning off the parking brake can be prevented if, before starting, the **(P)** button is pulled and held in the direction of arrow **1** » Fig. 260. The parking brake turns off after releasing the button.

Manual shut-down

- With the **ignition switched on**, press the brake pedal and at the same time push the **(P)** button in the direction of arrow **2** » Fig. 260.
- With the **engine running**, press either the brake or accelerator pedal and press the **(P)** button in the direction of arrow **2**.

The **(P)** symbol in the button and the warning light **(P)** in the instrument cluster go out.

Emergency braking function

If, while driving, a fault occurs in the brake system, the parking brake can be used as an emergency brake » **!**.

➤ Pull the **(P)** button in the direction of arrow **1** and » Fig. 260 hold (you hear an audible signal), the vehicle starts to brake **strongly**.

The braking process is interrupted when the key is released or the accelerator pedal is actuated.

! WARNING

- The emergency brake is to be used only in an emergency when the vehicle cannot be stopped with the brake pedal.
- Do not place any objects in the recessed grip for the finger in front of the parking brake key - the parking brake button could be blocked!

i Note

- If the vehicle battery is discharged, it is not possible to release the parking brake. First connect the vehicle first to a power source, such as the battery of another vehicle » page 288, *Jump-starting* and then turn off the parking brake.
- Noise when switching on and off the parking brake is normal and therefore harmless.

Auto Hold function



Fig. 261
The Auto-Hold function button

📖 **Read and observe** **!** on page 208 first.

The Auto Hold function (hereinafter referred to only as system) prevents the vehicle from rolling unintentionally when stopped. It is, for example, not necessary to secure the vehicle with the brake pedal or parking brake at traffic lights.

For the activation, deactivation and correct functioning of the system, the following basic conditions are required.

- ✓ The driver's door is closed.
- ✓ The engine is running (or has been switched off automatically by the START-STOP system).
- ✓ On vehicles with automatic transmission the selector lever is **not** in mode **N** (in this mode, the system is not available).

Stopping and starting

When stopping the system prevents the vehicle from rolling away. The warning light  illuminates in the instrument cluster. The brake pedal can be released.

The vehicle's brakes are released at the moment of stating off. The warning light  in the instrument cluster goes out.

Should the vehicle start to roll away backwards when starting on an uphill slope, step on the accelerator or switch on the parking brake.

If the vehicle is secured by the system and the driver's door is opened or the ignition is turned off, the vehicle is secured by the parking brake to prevent unwanted movement.

In this case, the indicator light turns off  in the instrument cluster and the warning light  illuminates.

Activation/deactivation

The system is activated/deactivated by means of the  » [Fig. 261](#) button.

When the system is activated, the symbol  illuminates.

After switching off and switching on the ignition, the system remains either activated or deactivated depending on the last setting.

WARNING

The increased stopping and starting comfort brought by the system must not tempt you to take any safety risks.

- The system is not able to stop the vehicle under all circumstances, such as on icy or otherwise slippery ground, or on gradients.
- When stopping and parking always make sure that the vehicle is correctly secured » [page 210](#), *Parking*.

CAUTION

In some washing systems it is necessary that the vehicle can roll freely. Therefore, the system must be deactivated before driving through a car wash.

Note

The system is able to secure the vehicle for about 10 minutes, after which the vehicle will be automatically secured by the parking brake.

Parking

 **Read and observe  on page 208 first.**

When stopping and parking, look for a place with a suitable surface » .

Only carry out the activities while parking in the specified order.

- Bring the vehicle to a stop and depress the brake pedal.
- The parking brake switch.
- On vehicles with **automatic transmission** place the selector lever in the **P** position.
- Switch off the engine.
- For vehicles with **manual transmission**, select **1st gear** or **reverse gear R**.
- Release the brake pedal.

If the parking brake is turned on while on a steep slope, the following message may be displayed in the instrument cluster. Search for a car park with less of an inclination.

WARNING

- The exhaust system components can become very hot. Therefore, never stop the vehicle at places where the underside of your vehicle can come into contact with flammable materials such as dry grass, undergrowth, leaves, spilled fuel or such like. - Risk of fire and serious injury can occur!
- When leaving the vehicle, never leave people who could, for example, lock the vehicle or release the brake, unattended in the vehicle - risk of accident and injury!

Manual gear changing and pedals

Introduction

! CAUTION

When stopping on a slope, never try to hold the vehicle using the accelerator pedal – this may lead to gear damage.

Manual gear changing

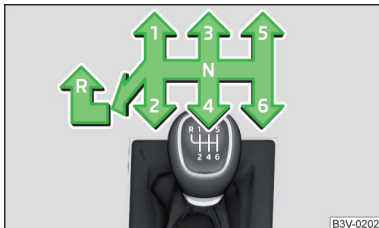

Fig. 262
The shift pattern

Read and observe ! on page 211 first.

The gearshift pattern for the individual gear positions is shown on the gear lever » Fig. 262.

The gear shift indicator should be observed when changing gear » page 49.

Always depress the clutch pedal all the way down. This prevents uneven wear on the clutch.

Engage reverse gear

- › Stop the vehicle.
- › The clutch pedal is fully depressed.
- › Switch the gear lever to **N**.
- › Push the shift lever downwards fully to the left and then forward into **R** » Fig. 262.

The reversing lights will come on once reverse gear is engaged, provided the ignition is on.

! WARNING

Never engage reverse gear when driving – risk of accident!

! CAUTION

If not in the process of changing gear, do not leave your hand on the gear shift lever while driving. The pressure from the hand can cause the gear shift mechanism to wear excessively.

Pedals

Read and observe ! on page 211 first.

The operation of the pedals must not be hindered under any circumstances!

In the driver's footwell, only a footmat (supplied by the factory or from the ŠKODA Original Accessories) which is secured on the respective attachment points should be used.

! WARNING

No objects should be located in the driver's footwell, otherwise the pedal operation could be disabled - risk of accident!

Automatic transmission

Introduction

The automatic transmission performs an automatic gear change irrespective of the engine load, the operation of the accelerator, the vehicle speed and the selected driving mode.

The modes of the automatic transmission can be adjusted by the driver by means of the selector lever.

! WARNING

- Do not use the throttle if the forwards mode has been set using the selector lever prior to starting up - risk of accident!
- Never move the selector lever to mode **R** or **P** when driving – risk of accident!

! WARNING (Continued)

- If the vehicle stalls, with engine running, in the **D**, **S**, **R** or Tiptronic mode, then the vehicle must be prevented from rolling away using the brake pedal, or using the Auto Hold function. Even when the engine is idling, the power transmission is never interrupted - the vehicle creeps.
- When leaving the vehicle, the selector lever must always be set to **P**. Otherwise, the vehicle could start to move - risk of accident.

! CAUTION

- If you want to move the selector lever from position **N** to position **D / S** whilst driving, the engine must be running at idling speed.
- When stopping on a slope, never try to hold the vehicle using the accelerator pedal - this may lead to gear damage.

Select selector lever position

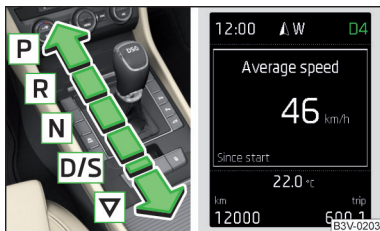

Fig. 263
Selector lever settings / display

Read and observe ! and ! on page 211 first.

Move the selector lever to change to the following positions » Fig. 263. In some positions you have to push the locking button » page 212, *Selector lever lock*.

When the ignition is switched on, the gearbox mode and the currently selected gear are indicated in the display » Fig. 263.

- P** **Park** - the position can be set only when the vehicle is at a standstill. The drive wheels are mechanically locked.
- R** **Reverse gear** - the position can be set only when the vehicle is at a standstill and the engine is at idling speed.
- N** **Neutral (idle position)** - the power transmission to the drive wheels is interrupted.

D/S **Forward mode / sports programme** - the gear change takes place in the position **S** at higher engine speeds than in mode **D**

▽ (Sprung position) - choice between positions **D** and **S**

If the Sport driving mode is selected with the engine running » page 244, *Select the driving mode (Driving Mode Selection)*, the transmission is automatically set in the **S** mode.

E – Economical driving mode

If the driving mode Eco or Individual (engine - Eco) » page 244 is selected and the selection lever is in the setting **D/S**, the transmission is automatically set to mode **E**. This mode cannot be selected with the selector lever.

The forwards mode is switched up or down automatically in mode **E** at lower engine speeds than in mode **D**.

Selector lever lock



Fig. 264
Shift lock button

Read and observe ! and ! on page 211 first.

The selector lever is locked in mode **P** and **N** to prevent that the forward driving is selected accidentally, thereby setting the vehicle in motion.

The selector lever is locked only when the vehicle is stationary and at speeds up to 5 km/h.

The selector lever lock is indicated by the illumination of the warning light.

Release the gear selector lever from P mode or N

» Press the brake pedal and, at the same time, push the lock button in the direction of arrow **1** » Fig. 264.

To move the selector lever from mode **N** to **D / S** only the brake pedal is pressed.

The selector lever is not locked when quickly moving across the position **N** (e.g. from **R** to **D/S**). This, for example, helps to rock out a vehicle that is stuck, e.g. in a bank of snow. The selector lever lock will engage if the lever is in position **N** for more than approx. 2 seconds without the brake pedal being depressed.

If it is not possible to release the gear selector from mode **P** in the usual manner, then this can be emergency unlocked » page 294.

i Note

If you want to switch the selector lever from mode **P** to mode **D/S** or vice versa, move the selector lever quickly. This prevents that you accidentally select mode **R** or **N**.

Manual shifting of gears (Tiptronic)

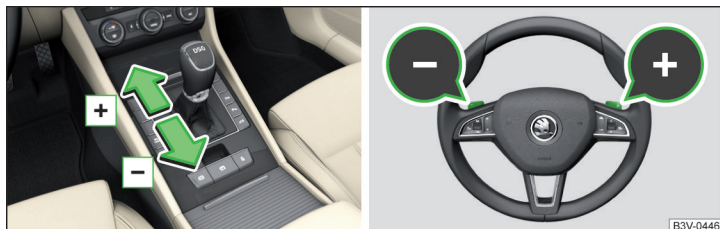

Fig. 265 Selector lever/multi function steering wheel

i Read and observe **i** and **i** on page 211 first.

Tiptronic mode makes it possible to manually shift gears with the selector lever or multifunction steering wheel.

Switching to manual shifting using the selector lever

► Push the gear selector from position **D/S** towards the right, or left in a right-hand drive vehicle. The current gear is maintained.

Switching to manual shifting by using the rocker switches under the multifunction steering wheel

- To **change gear**, pull one of the rocker switches **-/+** briefly towards the steering wheel » Fig. 265.
- To **cancel** manual shift, pull the rocker switch **+** towards the steering wheel for more than 1 s.

If you do not pull one of the rocker switches **-/+** for a certain time, manual shifting of the gears is deactivated automatically.

Changing gear

- To **shift up**, tap the selector lever forwards **+** or pull the rocker switch **+** briefly towards the steering wheel » Fig. 265.
- To **shift down**, tap the selector lever backwards **-** or pull the rocker switch **-** briefly towards the steering wheel » Fig. 265.

The currently selected gear is marked with the letter **M** in the instrument cluster display.

The gear shift indicator should be observed when changing gear » page 49.

When accelerating, the gearbox automatically shifts up into the higher gear just before the maximum permissible engine speed is reached. If a lower gear is selected, the gearbox does not shift down until there is no risk of the engine over revving.

i Note

It may be beneficial, for example, when travelling downhill, to use manual shifting of gears. Shifting to a lower gear reduces the load on the brakes and hence the wear of the brakes.

Start and run

i Read and observe **i** and **i** on page 211 first.

Starting and temporarily pausing

- Firmly depress and hold the brake pedal.
- Start the engine.
- Press the locking button and move the selector lever to the desired position » page 212.
- Release the brake pedal and accelerate.

The selector lever position **N** does not have to be selected if stopping for a short time, such as at cross roads. However, you must apply the brake pedal in order to prevent the vehicle from rolling away.

Accelerate to maximum speed during the journey (kickdown function)

The kickdown function is applied when the accelerator pedal is pressed down in the forward mode.

The gear change is adjusted accordingly to reach the maximum acceleration. ►

When approaching maximum speed (launch control function)

The launch control function is available in mode **S** or Tiptronic.



- ▶ Disable the TCS » page 217, *Braking and stabilisation systems*.
- ▶ START STOP deactivate » page 207, *Manually disable / enable system*.
- ▶ Fully depress and hold the brake pedal with your left foot.
- ▶ Fully depress the accelerator pedal with your right foot.
- ▶ Release the brake pedal - the vehicle is running at maximum acceleration.

Driving in neutral ("coasting")

When releasing the accelerator pedal, the vehicle moves without the braking effect of the engine.

Operating conditions

- ▶ The selector lever is in the **D/S** position.
- ▶ Driving mode Eco or Individual (Drive: - Eco) is selected » page 244, *Select the driving mode (Driving Mode Selection)*.
- ▶ The vehicle speed is 20-130 km/h.
- ▶ No trailer or other accessory is connected to the trailer socket.

The gear is selected again automatically, when you depress the accelerator or brake pedal or pull one of the rocker switches   towards the steering wheel » page 213, *Manual shifting of gears (Tiptronic)*.

! WARNING

Rapid acceleration, particularly on slippery roads, can lead to loss of control of the vehicle – risk of accident!

Running in the engine and economical driving

Running in the engine

During the first 1,500 km, the driving manner determines the quality of the running in process on a new engine.



During the first 1,000 km, the engine should not be charged with more than 3/4 of the maximum permitted engine revs and without the trailer.

In the area of **1,000 to 1,500 kilometres**, the engine load can be increased up to the maximum permitted engine speed.

Tips for economical driving

The fuel consumption depends on the driving style, road condition, weather conditions and the like.

For an economical driving style, the following instructions must be observed.

- ▶ Avoid unnecessary acceleration and braking.
- ▶ Observe the recommended gear » page 49.
- ▶ Avoid full throttle and high speeds.
- ▶ Reduce idling.
- ▶ Avoid short distances.
- ▶ Ensure the correct tyre inflation pressure is maintained » page 277.
- ▶ Avoid unnecessary ballast.
- ▶ Remove the roof rack when it is not needed.
- ▶ Only switch on electrical consumers (e.g. seat heating) for as long as they are needed. In the infotainment system, in menu   →  → **Fuel consumption**, it is possible to display up to three consumers that are currently making up the largest share of fuel consumption.
- ▶ Before switching on, ventilate the cooling system briefly and do not use the cooling system with open windows.
- ▶ Do not leave windows open at high speed.

DriveGreen function

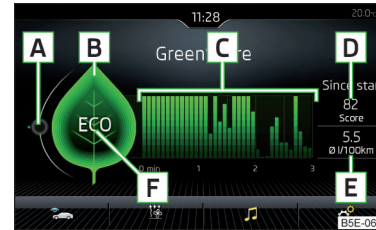





Fig. 266
Display in Infotainment screen

The DriveGreen function (hereinafter referred to as DriveGreen) evaluates the driving efficiency based on the information respecting the driving style.

DriveGreen can be displayed in the infotainment screen in menu   →  → **DriveGreen**.

A driving liquid display

With the driving is fluid, the display is located in the middle (near the green dot). When accelerating, the display moves down, and upwards when braking.

B "Green leaf"

The greener the leaf, the more economic the driving style. With less economical driving, the leaf is presented without any green colouring or it can be completely hidden.

C bar graph

The higher the green bars, the more economical the driving style. Each bar shows the driving efficiency in 5-second steps, the current bar is on the left.

D scoring (0 - 100)

The higher the indicated value, the more economical the driving style. When you tap the function surface **D**, a detailed assessment showing the driving efficiency during the last 30 minutes is displayed.

If the trip lasts less than 30 minutes from the start, then the overview will add the assessment from the previous journey (the bars are shown in dark green).

E the average fuel consumption from the start

When you tap the **E** function surface, a detailed overview of the average fuel consumption during the last 30 minutes is shown.

If the trip lasts less than 30 minutes from the start, then the overview will add the overview of the average fuel consumption from the previous journey (the bars are shown in dark green).

F symbols

The display may show the following four symbols, which give information on the current driving style.

ECO Economical driving style

 The current speed has a negative effect on fuel consumption.

 Travelling is not fluid, this is to avoid unnecessary acceleration and braking

 Recommended gear

Tips for economical driving

Tap on the **B** leave to display tips for economical driving.

i Note

Resetting the single-trip memory "Since start" also resets the average consumption **E** and the driving assessment **D** as well as diagram **C**.

Radiator shutters

The radiator shutters located in front of the radiator (hereinafter: shutter) help to reduce CO₂ emissions as well as harmful emissions and to save fuel.

If the system detects that it is possible to reduce the amount of air flowing to the radiator, it closes the blinds. As a result, the air resistance of the vehicle is reduced.

If a driving speed of 150 km/h is reached due to a **function impairment** of the shutters, a message regarding the function impairment of the shutters is shown in the instrument cluster display.

After this message has been displayed, the maximum speed of the vehicle is automatically limited to 170 km/h. The manner of driving should therefore be adapted to this limitation.

If this message appears in the winter, the cause may be ice or snow caught up in the blinds. After the ice or snow has thawed, the blinds are functional again.

If the impairment not due to ice or snow, then assistance from a specialist should be sought.

Avoiding damage to your vehicle

Driving Tips

Only drive on such roads and in such terrain that match the vehicle parameters » [page 304](#), *Technical data* as well as your driving skills.

The driver is always responsible for deciding whether the vehicle can handle travelling in the given terrain.

! WARNING

- Adjust the speed and driving style to the current visibility, weather, road and traffic conditions. Too high a speed or an erroneous manoeuvre may cause serious injury and damage to the vehicle.
- Combustible objects such as dry leaves or twigs caught under the base of the vehicle could ignite on hot vehicle parts - risk of fire!

! CAUTION

- Pay attention to the ground clearance of the vehicle! When driving over objects which are larger than the ground clearance, the vehicle can get damaged.
- Any objects that get trapped under the vehicle floor must be removed as soon as possible. These items can cause damage to the vehicle (e.g. on parts of the fuel system or the brake system).

Driving through water

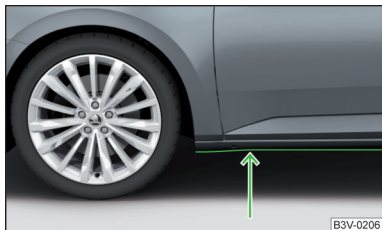

Fig. 267
Maximum permissible water level when driving through water

The following must be observed to avoid damage to the vehicle when driving through bodies of water (e.g. flooded roads).

- Therefore determine the depth of the water before driving through bodies of water. The water level must not reach above the lower edge of the lower brace » Fig. 267.
- Drive at a maximum speed of walking pace, otherwise a shaft may form in front of the vehicle which could enable water to enter the vehicle system (e.g. in the air induction system of the engine).
- Never stop in the water, do not reverse and do not switch the engine off.

! CAUTION

- Water entering the vehicle systems (e.g. the air induction system of the engine) can cause serious damage to the vehicle!
- Oncoming vehicles can generate water waves which can exceed the permissible water level for your vehicle.
- Do not drive through salt water, as the salt can cause corrosion. An vehicle coming into contact with salt water is to be thoroughly rinsed with fresh water.

Assist systems

General information

📖 Introduction

! WARNING

- The assistance systems only serve to support the driver and do not relieve the driver of the responsibility for driving the vehicle.
- The increased safety provision, as well as the increased occupant protection provided by the assistance systems must not tempt you to take risks - risk of accident!
- Adjust the speed and driving style to the current visibility, weather, road and traffic conditions.
- The assistance systems have physical and system-related limitations. For this reason, the driver may experience some undesired or delayed system responses in certain situations. You should therefore always be alert and ready to intervene!
- Only enable, disable or set the assistance systems when you have the car fully under control, in every traffic situation - risk of accident!

Radar sensor



Fig. 268
Installation location of the radar sensor

📖 **Read and observe ! on page 216 first.**

The radar sensor (hereinafter referred to only sensor) uses electromagnetic waves to capture the traffic situation ahead of the vehicle. The radar is located under a cover » Fig. 268.

The sensor is part of the ACC » page 236 and Front Assist » page 242 systems. ▶

The sensor function may be impaired in the event of one of the following situations arising.

- ▶ The sensor cover is soiled (e.g. with mud, snow and the like).
- ▶ The area in front of and around the sensor cover is obscured (e.g. by labels, auxiliary headlights and the like).
- ▶ When visibility is poor (e.g. fog, heavy rain, thick snowfall).
- ▶ In exceptional cases, the sensor may be covered in the area beneath the cover, e.g. due to snow.

If the sensor cover or the sensor is dirty or covered, a message to that effect from the ACC system » [page 241](#), *Malfunctions* or Front Assist » [page 244](#), *Malfunctions* system appears in the instrument cluster display.

! WARNING

- If you suspect that the sensor is damaged, deactivate the ACC system and Front Assist system » [page 239](#), » [page 243](#). Have the sensor checked by a specialist garage.
- A collision or damage in the front or lower area of the vehicle could affect the sensor function - there is risk of accident! Have the sensor checked by a specialist garage.
- Do not cover the area in front of and around the sensor cover. This can lead to impaired function of the sensor - risk of accident!

! CAUTION

Remove snow with a brush and ice with a solvent-free de-icer from the sensor cover.

Braking and stabilisation systems

Introduction

The brake and stabilization systems are automatically activated each time the ignition is switched on, unless otherwise indicated.

The error display is in Chapter » [page 39](#), *Warning lights*.

! WARNING

The general information relating to the use of assistance systems must be observed » [page 216](#), ! in section *Introduction*.

Stability Control (ESC)

📖 **Read and observe !** on [page 217](#) first.

ESC improves vehicle stability in critical driving situations (e.g. if the vehicle starts to skid) by the braking the individual wheels to maintain the direction.

During an ECS intervention, the warning light 🚨 flashes in the instrument cluster.

ESC Sport



Fig. 269
ESC Sport / ASR system button

📖 **Read and observe !** on [page 217](#) first.

ESC Sport allows for a sportier driving style. With ESC Sport switched on, in the event of light oversteer or understeer of the vehicle, no ESC interventions take place and the ASR is so limited that the drive wheels can spin.

Activation

- ▶ Press and hold down the 🚨 » [Fig. 269](#) button.
- ▶ **or:** In the infotainment system, in menu / tap on function surface 🚨 → ESC system: → ESC Sport.

With **activation** the warning light 🚨 **lights up** in the instrument cluster and an appropriate message is displayed in the instrument cluster.

Deactivation

- ▶ Press the 🚨 » [Fig. 269](#) button.
- ▶ **or:** In the infotainment system, in menu / tap on function surface 🚨 → ESC system: → Activated.

With **deactivation** the warning light 🚨 **extinguishes** in the instrument cluster and an appropriate message is displayed in the instrument cluster.

Anti-lock brake system (ABS)

 **Read and observe**  on page 217 first.

ABS prevents the wheels locking when braking. Thus helping the driver to maintain control of the vehicle.

An ABS intervention can be noticed through **pulsating movements of the brake pedal** and distinct noises.

When the ABS system is active, do not brake periodically or reduce the pressure on the brake pedal.

Engine drag torque control (MSR)

 **Read and observe**  on page 217 first.

The MSR prevents the blocking tendency of the drive wheels when shifting down or with an abrupt deceleration (e.g. on icy or otherwise slippery road surfaces).

If the drive wheels lock, the engine speed is automatically increased. This reduces the braking effect of the engine, and the wheels can rotate freely again.

Traction control (ASR)



 **Read and observe**  on page 217 first.

The ASR prevents spinning of the drive wheels. TCS reduces the drive power transmitted to the wheels in the case of slipping wheels. Thus, for example, driving on road surfaces with low grip is made easier.

During a TCS intervention, the indicator light  flashes in the instrument cluster.

Deactivation



▶ Press the  » Fig. 269 on page 217 button.

▶ **or:** In the infotainment system, in menu  tap on function surface  → ESC system: → ASR off.

With **deactivation** the warning light **lights up** in the instrument cluster  and an appropriate message is displayed in the instrument cluster.

Activation

▶ Press the  » Fig. 269 on page 217 button.

▶ **or:** In the infotainment system, in menu  tap on function surface  → ESC system: → Activated.

With **activation** the warning light  is **extinguished** and an appropriate message is displayed in the instrument cluster.

The TCS should normally always be enabled. The system should be deactivated only in the following situations, for example.

- ▶ When driving with snow chains.
- ▶ When driving in deep snow or on a very loose surface.
- ▶ When it is necessary to “rock” a car free when it has become stuck.

Electronic Differential Lock (EDL and XDS)

 **Read and observe**  on page 217 first.

EDL prevents the turning of the respective wheel of the driven axle. EDL brakes the spinning wheel, if necessary, and transmits the driving force to the other driving wheel. Driving becomes easier on road surfaces with different traction under each wheel of the driven axle.

EDL switches off automatically to avoid excessive heat generation on the brake of the wheel being braked. Once the brakes have cooled down, there is an automatic re-activation of EDL.

XDS+ is an extension to the electronic differential lock (EDL). The XDS+ responds to the release of pressure on the wheels during fast cornering by means of a braking intervention on the wheel on the inside of the corner on the driven axle. By decelerating the individual wheels, this prevents the vehicle from over-steering or understeering. This has a positive effect on the driving stability and steerability of the vehicle.

Active steering assist (DSR)

 **Read and observe**  on page 217 first.

In critical situations, the DSR provides the driver with a steering recommendation in order to stabilise the vehicle. DSR is activated, for example, on the right and left vehicle side when braking sharply on different road surfaces.

Brake Assist (HBA)

 **Read and observe**  on page 217 first.

The HBA increases the braking effect and helps to reduce the braking distance.

The HBA is activated by very quick operation of the brake pedal. In order to achieve the shortest possible braking distance, the brake pedal must be applied firmly until the vehicle has come to a standstill.

The HBA function is automatically deactivated when the brake pedal is released.

Hill Start Assist

 **Read and observe**  on page 217 first.

When driving on slopes, Hill Start Assist (hereinafter referred to simply as the system) allows you to move your foot from the brake pedal to the accelerator pedal without the vehicle rolling downhill on its own.

The vehicle is braked by the system for about 2 seconds after releasing the brake pedal.

The system is active as of a 5% slope, if the driver door is closed. The system is only ever active on slopes when starting off in forward or reverse.

Multicollision brake (MCB)

 **Read and observe**  on page 217 first.

MCB helps to decrease speed after a collision by means of automatic braking interventions and to stabilise the vehicle. This reduces the risk of a subsequent crash due to uncontrolled vehicle movement.

The automatic brake interventions can take place only if the following conditions are met.

- ✓ There was a front, side and rear-end collision of a certain severity.
- ✓ The impact speed was greater than approx. 10 km/h.
- ✓ The brakes, the ESL and other required electrical systems remain functional after impact.
- ✓ The accelerator pedal is not actuated.

Trailer stabilisation system (TSA)

 **Read and observe**  on page 217 first.

The TSA helps the combination stable in situations where the trailer sways and then the whole trailer combination.

TSA brakes the individual wheels of the towing vehicle in order to damp the rocking motion of the entire vehicle combination.

The following conditions are required for the correct TSA function.

- ✓ The trailer was shipped from the factory or purchased from the ŠKODA genuine accessories.
- ✓ The trailer is electrically connected to the towing vehicle via the trailer socket.
- ✓ The parking aid is activated.
- ✓ The speed is greater than 60 km/h.

Further information » [page 254](#), *Towing device and trailer*.

Parking aid (ParkPilot)

Introduction

The parking aid (hereinafter referred to as system) uses acoustic signals or the Infotainment screen when manoeuvring around obstacles in the vicinity of the vehicle.

WARNING

- The general information relating to the use of assistance systems must be observed » [page 216](#),  in section *Introduction*.
- Moving persons or objects may not be recognized by the system sensors.
- Under certain circumstances, surfaces of certain objects and types of clothing cannot reflect the system signals. There is a danger that such objects or people may not be recognised by the system sensors.
- External noise sources may affect the signals of the system sensors. There is a danger that obstacles may not be detected by the system sensors.
- Before reversing, make sure that there are is not any small obstacle, such as a rock, thin post etc., in front of or behind your vehicle. Such obstacles may not be recognised by the system sensors.

! CAUTION

- Keep the system sensors » Fig. 270 on page 220 clean, snow-and-ice-free and do not cover with any objects of any kind, otherwise the system functioning may be impaired.
- Under adverse weather conditions (heavy rain, water vapour, very low or high temperatures, etc.), the system function may be limited - "incorrect recognition of obstacle".
- Accessories fitted to the vehicle rear, such as bicycle carriers, can impair the system function.

Settings in Infotainment

📖 Read and observe ! and ! on page 219 first.

➤ In the infotainment system, in menu / tap on function surface → Parking and manoeuvring.

- **ParkPilot** - Settings for the parking aid
 - **Activate automatically** - Activate/deactivate the compact parking aid display (when driving forward)
 - **Front volume** - Adjust the volume of the beeps for obstacle detection in front
 - **Front tone setting** - Setting the pitch of the beeps for obstacle detection in front
 - **Rear volume** - Set the volume level of the beeps for the rear obstacle detection
 - **Rear tone setting** - Setting the pitch of the beeps for the rear obstacle detection
 - **Entertainment fading while parking** - Lowers the audio volume (e.g. radio volume) with activated parking aid
 - **Manoeuvre braking** - Activation / deactivation of the automatic emergency braking

Operation

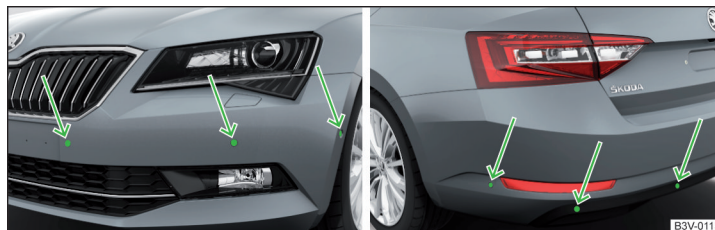

Fig. 270 Installation location of the sensors on the left side of the vehicle: front/rear

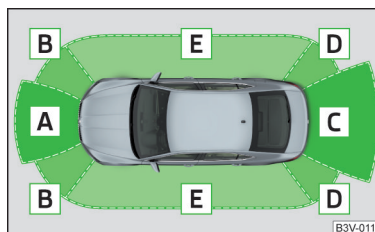

Fig. 271 Sampled areas and range of the sensors

📖 Read and observe ! and ! on page 219 first.

The system uses ultrasound waves to calculate the distance between the bumper and an obstacle. The ultrasonic sensors are, depending on vehicle equipment, located in the back or in the front bumper » Fig. 270.

Depending on the equipment, the following system versions are possible » Fig. 271.

- ▶ Variant 1: warns of obstacles in areas **C, D**.
- ▶ Variant 2: warns of obstacles in areas **A, B, C, D**.
- ▶ Variant 3: warns of obstacles in the areas **A, B, C, D, E**.

Approximate range of sensors (in cm)

Area » Fig. 271	Variante 1 (4 sensors)	Variante 2 (8 sensors)	Variante 3 (12 sensors)
A	-	120	120
B	-	60	90
C	160	160	160
D	60	60	90
E	-	-	90

Audible signals

The interval between the acoustic signals becomes shorter as the clearance is reduced. At a distance of approx. 30 cm a continuous tone starts to sound - Danger area.

The acoustic signals can be set in Infotainment » page 220.

Towing a trailer

When towing, or when another accessory is connected to the trailer socket, only the areas **A** and **B** » Fig. 271 are active in the system.

Note

- If with **Versión 3** vehicles not all fields around the vehicle silhouette are active after activation the vehicle should be moved forwards or backwards.
- The signal tones for front obstacle recognition are factory-set to be higher than for rear obstacle recognition.
- The setting of the acoustic signals is stored (depending on the Infotainment type) in the active user account personalisation » page 55.

Display in Infotainment screen

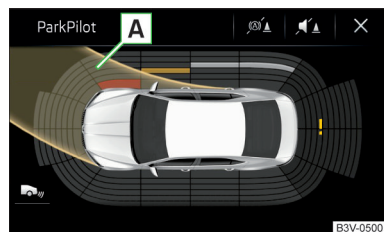

Fig. 272
Screen display

Read and observe **!** and **!** on page 219 first.

Function surfaces and warnings » Fig. 272

- A** Road display.
- X / ↵ Depending on the Infotainment type: Switching off park assistant display.
- 🔊 / 🔇 Switching audible parking signals on/off.
- 🚗 Disable / enable the automatic emergency braking.
- 📷 Change to rear-view camera display.
- 🔴 There is an obstacle in the collision area (the distance to the obstacle is less than 30 cm). 🛑 Stop moving in the direction of the obstacle!
- 🟡 There is an obstacle in the road (the distance to the obstacle is greater than 30 cm).
- ☐ An obstacle is located outside of the road (the distance to the obstacle is greater than 30 cm).
- ! System failure (there is no indication of obstacles).

Road display

The road display **A** » Fig. 272 indicates the road on which the vehicle would take the current steering wheel and shift / selector lever position.

The shift lever is in the neutral position and the gear selector is in mode **N**. the road display is at the front.

Activation / deactivation



Fig. 273
System key (option 2, 3)

Read and observe  and  on page 219 first.



Activation

To activate the system, engage reverse gear and, on vehicles with **version 2 and 3**, also press the  » [Fig. 273](#) button.

When activating, an alarm sounds and the symbol  illuminates in the button.

Deactivation

On vehicles with **Version 1**, the system can be deactivated by moving out of reverse gear.

For vehicles with **version 2 and 3**, the system is automatically deactivated by pressing the  button or at a speed above 15 km/h (the  symbol in the button goes out).

Fault display

Vehicles with **Variant 1**

- ▶ After system activation an acoustic signal sounds for approx. 3 seconds (there is no obstacle near the vehicle).

Vehicles with the **Variants 2 and 3**

- ▶ After system activation, the  symbol flashes in the button.
- ▶ In the display of the instrument cluster a message about an error of the Park-Pilot system appears (at the same time there is an audible signal).

Seek help from a specialist garage.

Note

The system can only be activated with the  button at a speed of below 15 km/h.

Automatic system activation when moving forward

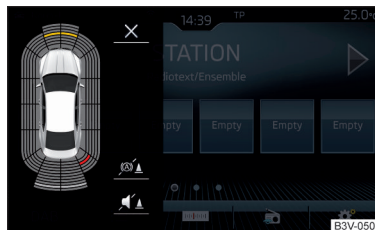

Fig. 274
Infotainment screen: Display with automatic activation

Read and observe  and  on page 219 first.

The automatic system activation occurs when moving forward at a speed below 10 km/h when the vehicle approaches an obstacle.

After activation, the following is shown in the left pane of Infotainment display » [Fig. 274](#).

Acoustic signals are sounded as of a distance from the obstacle of around 50 cm.

The automatic display can be activated / deactivated in Infotainment » [page 220](#).

Note

The setting (activate / deactivate) of the automatic display is stored (depending on the Infotainment type) in the active user account personalisation » [page 55](#).

Automatic emergency braking

Read and observe  and  on page 219 first.

If the system detects a collision risk when travelling forwards or reversing at a speed up to 8 km/h, there is an automatic emergency braking to reduce the impact consequences.

Disable / Enable

The brake function can be enabled / disabled in the Infotainment in the menu **Parking and manoeuvring** » [page 220](#).

After switching the ignition on and off, the systems remains activated / deactivated depending on the setting prior to switching off the ignition.

The brake function can also be deactivated once with the function surface  » Fig. 272 on page 221.

CAUTION

Automatic emergency braking will only work if the system is engaged by engaging reverse gear or pressing the button  has been activated.

Rear traffic alert and wizard for “Blind spot”Monitoring

Introduction



Fig. 275
Installation location of the radar sensors

The Rear Traffic Alert and Wizard for “blind spot” monitoring works based on the information from the radar sensors in the rear bumper » Fig. 275. The radar sensors are not visible from the outside.

Rear Traffic Alert

The Rear Traffic Alert (hereinafter referred to as system) warns when leaving a parking space from a transverse parking space about any approaching vehicles.

If necessary, the system tries to avoid a collision with automatic braking, or at least to mitigate the consequences.

Wizard for “blind spot”monitoring

The wizard for “blind spot monitoring” (hereafter referred to as system) draws attention to vehicles travelling in the same direction in the next lane in the so-called blind spots.

The “blind spot” is an area that is not easily visible in a rear-view mirror or even directly from the vehicle.

WARNING

The general information relating to the use of assistance systems must be observed » page 216,  in section *Introduction*.

WARNING

- In the case of a collision or damage to the rear of the vehicle, the function of the systems may be affected - risk of accident! Have the vehicle checked by a specialist garage.
- Do not cover the sensor area - the function of the systems could be limited.
 - Remove snow, ice and such obstacles from the sensor environment immediately.

WARNING

- The wizard for “blind spot” monitoring is limited by physical and system-related limits. Therefore, in the following situations the system can be delayed in drawing attention (or not at all) to a vehicle in the next lane.
- When a vehicle is approaching at a very high speed.
 - When passing through a very sharp curve or a roundabout.

CAUTION

- If a trailer or other accessory is to be connected to the trailer socket, then the two systems are not available.
- In adverse weather conditions (heavy rain, water vapour, very low or high temperatures, etc.), the system function may be limited - “failure to recognise a vehicle”.
- Accessories additionally installed on the vehicle rear, such as bicycle carriers, can impair the system function.

Rear Traffic Alert- Operation

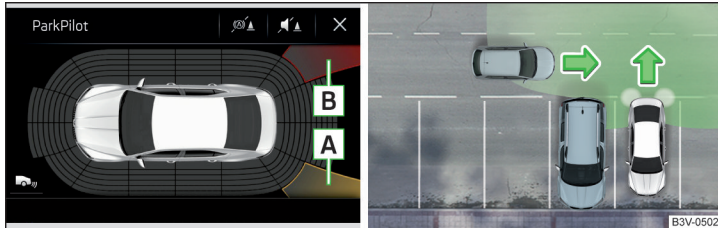



Fig. 276 Infotainment screen: warning indicator / driving situation

Read and observe **A** and **B** on page 223 first.

With the ignition switched on, the area next to and behind the vehicle is monitored by the radar sensors of the system. If an approaching vehicle is detected from the rear of the vehicle » Fig. 276, the system warns of this fact.

Warning - vehicles with parking aid

You will hear a continuous tone and one of the following warning levels appears on the Infotainment screen » Fig. 276.

- A** An oncoming vehicle is detected. Do not continue driving backwards and check around the vehicle.
- B** A vehicle in the collision region is detected. Do not continue driving backwards .

Warning - vehicles without parking sensors

An acoustic signal is sounded and information for the driver to observe the traffic behind is shown in the instrument cluster.

Automatic emergency braking

If the driver does not react to the warning and the system detects an impending collision, then this can trigger an automatic braking at a speed up to 10 km/h. A corresponding message is shown in the information cluster display.

Wizard for “Blind Spot”Monitoring - Operation

Read and observe **A** and **B** on page 223 first.

At a speed over 15 km/h, the area alongside and behind the vehicle is monitored by the system. At the same time, the distance and the difference in speed between your vehicle and the other vehicles in the monitored area can be measured.

When driving, the sensors monitor an area to the left and right to the extent of a normal lane width.

If a vehicle is detected in the “blind spot” area, the system indicates this vehicle by the indicator light  in the exterior mirror.

System constraint

The system is unable to recognise the specific lane width by means of sensors. Therefore this can e.g. in the following cases respond to a vehicle in a further lane.

- ▶ When driving on a road with narrow lanes or on the lane edge.
- ▶ Driving around a bend.

The system may also respond to objects on the roadside such as crash barriers, noise barriers or similar objects.

Wizard for “Blind Spot”Monitoring - driving situations and warnings



Fig. 277 Driving situation / indicator light in the left outside mirror indicates the driving situation



Fig. 278 Driving situation / indicator light in the right outside mirror indicates the driving situation

Read and observe **!** and **!** on page 223 first.

In the following situations, the indicator light in the outside mirror indicates a vehicle in the “blind spot”.

- ▶ Your vehicle **B** is being overtaken by vehicle **A** ▶ Fig. 277.
- ▶ Your vehicle **C** is overtaking vehicle **D** at a speed of max. 10 km higher ▶ Fig. 278. If the speed during the overtaking is even higher, then there is no warning by the warning light.

The warning display is always in the exterior mirror on the side of the vehicle where a vehicle is detected in the “blind spot”.

The greater the speed difference between the two vehicles, the earlier the warning (by means of the warning light) regarding the vehicle that is overtaking you takes place.

Two warning levels

light up - a vehicle has been detected in the “blind spot”.

flash - a vehicle has been detected in the “blind spot” and the **turn signal is switched on**.

An advanced warning for vehicles with Lane Assist

flash also if the **steering wheel** is turned in the direction of the vehicle in the “blind spot”. Therefore the Lane Assist ▶ page 247 must be enabled and the boundary line between the vehicles detected.

If in this case your vehicle indicates crossing the boundary line, with a short vibration of the steering wheel.

Note

The brightness of the indicator light is dependent on the setting of the vehicle lighting. With the low or high beam on the brightness of the light will be lower.

Activation / deactivation

Read and observe **!** and **!** on page 223 first.

The activation or deactivation of the system can be carried out in one of the following ways.

- ▶ In the instrument cluster display ▶ page 54, **Assist systems menu item**.
- ▶ In the infotainment system, in menu **CAR/** → → **Driver assistance** (applies to the wizard for “blind spot” monitoring).
- ▶ In the infotainment system, in menu **CAR/** → → **Parking and manoeuvring** (Applies to Rear Traffic Alerts).

After switching off and switching on the ignition, depending on the setting prior to switching off the ignition, the systems remains activated / deactivated.

Note

When activating the wizard for “blind spot” monitoring, the warning lights illuminate briefly in the two exterior mirrors.

Malfunctions

Read and observe **!** and **!** on page 223 first.

If the systems are not available, an appropriate message appears in the display of the instrument cluster.

Sensor covered / dirty

If the sensor is dirty or covered, a message indicating that there is no sensor view appears. Clean or remove the obstructing object from the sensor environment ▶ Fig. 275 on page 223.

Systems unavailable

If the systems are unavailable, a message regarding unavailability appears. Stop the vehicle, switch off the engine and then start it again. If the systems are still not available, seek the assistance of a specialist garage. ▶

System fault

In the case of a system fault, an error message appears. Seek help from a specialist garage.

Rear View Camera

Introduction

The rear view camera (following as system) helps the driver when parking and manoeuvring by displaying the area behind the vehicle in the Infotainment screen (hereinafter only referred to as screen).

There are four modes available for different situations during the park and manoeuvring action. The mode change is carried out using the function surfaces on the screen» [page 227](#).

! WARNING

- The general information relating to the use of assistance systems must be observed » [page 216](#), ! in section *Introduction*.
- The system displays auxiliary boxes and lines regardless of the current vehicle environment. The driver is responsible for checking that there is no obstacle in the selected parking space and that the vehicle can safely park in this space.
- The camera may not be soiled or obscured, otherwise the system function will be significantly affected - there is a risk of accident. For information on cleaning » [page 262](#).

! CAUTION

- The camera image is distorted by contrast with eyesight. For this reason, the screen display is only of limited use for estimating distances to following vehicles.
- Some items, such as narrow columns, chain link fences, lattices or roadway irregularities may not be represented adequately in terms of screen resolution.
- In a crash or damage the vehicle's rear camera can possibly deviate from the correct position. If this is the case, have the sensor checked by a specialist garage.

i Note

The camera is equipped with a cleaning system. Spraying takes place automatically, together with spraying the rear or windscreen.

226 Driving

Operation

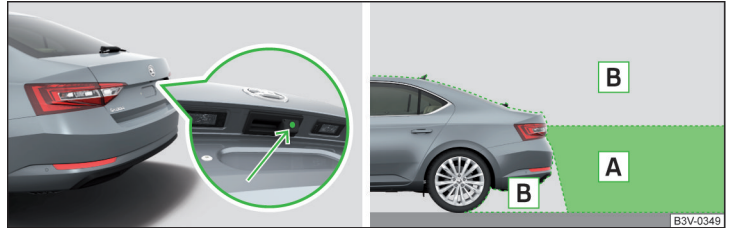

Fig. 279 Installation location of the camera / scanned area behind the vehicle

📖 Read and observe ! and ! on page 226 first.

The camera for capturing the area behind the vehicle is in the grip of the boot lid » [Fig. 279](#).

Area behind the vehicle » [Fig. 279](#)

- A** Detection range of the camera
- B** Area outside the detection range of the camera

The system can assist the driver when parking and manoeuvring under the following basic conditions.

- ✓ The ignition is switched on.
- ✓ The system is activated.
- ✓ The luggage compartment lid is completely closed.
- ✓ The vehicle is travelling at less than 15 km/h.
- ✓ The area behind the vehicle is clearly visible.
- ✓ The selected parking / manoeuvring area is clear and even.

Activation/deactivation



Fig. 280
Button for activation / deactivation

Read and observe **I** and **II** on page 226 first.

Activation

The system is activated by selecting reverse gear or pressing the symbol **P** button » Fig. 280.

When activating, an alarm sounds and the symbol **P** illuminates in the button.

The mode for traverse parking is displayed on the screen.

Deactivation

The system is deactivated when you press button **P**, switch off the ignition, put the selector lever in position **P**, or when you drive forwards at a speed of more than 15 km/h (the **P** symbol in the button goes out).

Function surfaces

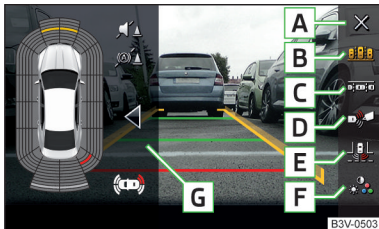

Fig. 281
Function surfaces

Read and observe **I** and **II** on page 226 first.

It is possible to adjust the parking and manoeuvring mode by means of the function surfaces.

Function surfaces » Fig. 281

- A** Turns off the display of the area behind the vehicle
- B** Mode - traverse parking
- C** Mode - parallel parking
- D** Mode - driving up to a trailer / distance monitoring
- E** Mode - monitor the area behind the vehicle (wide view)
- F** Screen settings - brightness, contrast, colour
- G** Parking aid (mini display)
 - ◀ / ▶ Switch thumbnail display on/off
 - ☐ Switch to full screen display

Orientation lines and lane

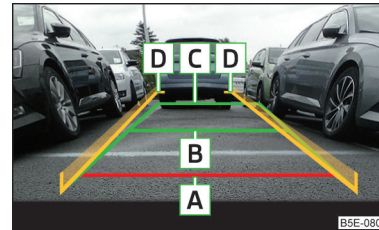

Fig. 282
Orientation and lane lines

Read and observe **I** and **II** on page 226 first.

In the modes for transverse and parallel parking guidance, orientation lines for the assessment of distance and lane lines are displayed on the screen.

Screen display » Fig. 282

- A** The distance is about 40 cm (safety distance limit).
- B** The distance is about 100 cm.
- C** The distance is about 200 cm.
- D** The lane lines terminate approximately 300 cm behind the vehicle.

The distance may vary slightly depending on the load of the vehicle and the road inclination.

The distance between the side lines corresponds approximately to the vehicle width including mirrors. ▶

Lane

The lane lines **D** » Fig. 282 change depending on the steering angle and indicate the roadway on which the vehicle would take with the current steering wheel position.

! CAUTION

The objects shown on the screen can be closer or even further away than they appear. This is especially the case in the following situations.

- Protruding objects, such as the rear of a truck and the like.
- When driving from a horizontal surface into a slope or a depression.
- When driving from a slope or a depression onto a horizontal surface.

Mode - traverse parking

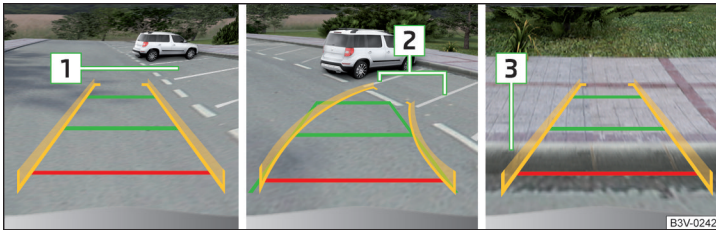

Fig. 283 Screen display

📖 Read and observe **!** and **!** on page 226 first.

This mode supports the driver when reverse parking in a parking space that is transverse to the road.

Parking manoeuvre

- Select a suitable parking space.
- Press the **P** » Fig. 280 on page 227 button.
- At the selected parking space **1** » Fig. 283 slowly drive past and stop the vehicle.
- Engage reverse gear.
- Adjust the steering wheel so that the lane lines lead into the parking space **2**.
- Carefully move backward and steer so that the yellow lines are still leading into the parking space.

- At the latest when the red line of the back of the parking space (for example, curb) **3** is touched, stop the vehicle.

Mode - parallel parking

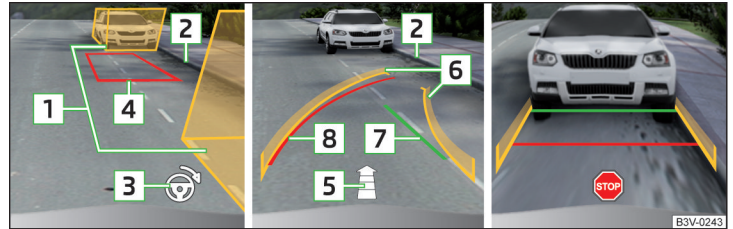

Fig. 284 Screen display

📖 Read and observe **!** and **!** on page 226 first.

This mode supports the driver when reverse parking in a parking space that is parallel to the road.

Parking manoeuvre

- When driving past a parking space push the button **P** » Fig. 280 on page 227.
- Tap the function surface **C** » Fig. 281 on page 227.

The screen shows auxiliary boxes for both road sides.

- Switch on the indicator for the side on which you want to park.

The auxiliary boxes for the opposite side will be hidden.

- Stop the vehicle stop so that there are no obstructions in the gap between the auxiliary boxes **1** » Fig. 284 and the rear box does not extend over the side of the parking space **2** (e.g. kerb).
- Turn the steering wheel in the direction recommended **3** until the colour of the trapezoidal frame **4** is green. Hold the steering wheel in this position.
- Once the arrow **5** appears on the screen, reverse (when reversing in the parking space the arrow will get shorter).

The screen shows the yellow lane lines **6** and the green line **7**.

If the steering angle is corrected while reversing then the red line **8** appears (required roadway alignment).

- › In this case, adjust the steering wheel so that the yellow lines **6** the red line **8** fade into each other.
- › Carefully reverse until **!** appears on the screen or the green line **7** is congruent with the lateral boundary of the parking space (e.g. kerb) **2**.
- › Stop the vehicle and steer opposite until the yellow lines **6** the red line **8** fade into each other (required roadway alignment). Hold the steering wheel in this position.

Orientation lines are displayed » Fig. 282 on page 227 on the screen.

- › Carefully move backwards.
- › Stop the vehicle when **!** appears on the screen, or at a safe distance from the obstacle situated behind the vehicle.

i Note

The guidance in the parking space is cancelled due to the system when the steering wheel is set for a period of time against the required road direction. The parking is to be started again.

Mode - driving up to a trailer / distance monitoring

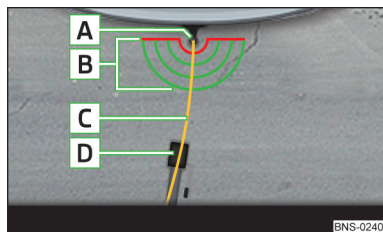

Fig. 285
Screen display

! Read and observe **!** and **!** on page 226 first.

In this mode, the area behind the vehicle is shown at the top of the screen.

Vehicles with towing hitch

If your vehicle is factory fitted with a tow-bar, this mode supports the driver when the vehicle approaches a trailer draw bar.

Screen display » Fig. 285

- A** Ball head of the towing device
- B** Lines for the distance estimation (at a distance of about 10 cm)

- C** Line for approaching a trailer draw bar
- D** Trailer draw bar

The line **C** moves depending on the steering angle and indicate the roadway on which the vehicle would take with the current steering wheel position.

Vehicles without towing hitch

If your vehicle is not factory equipped with a towing hitch, a red line for monitoring the distance to obstacles is displayed on the screen at a distance of 40 cm behind the vehicle.

Mode - monitor the area behind the vehicle

! Read and observe **!** and **!** on page 226 first.

In this mode, the area behind the vehicle is shown on the screen.

The mode is suited for the entire view of the situation behind the vehicle.

Park Assist

! Introduction

Park Assist (following referred to system) helps drivers park in suitable parallel and perpendicular parking places or also to manoeuvre out of parallel parking spaces.

The system takes over the steering movements **only** when parking or leaving a parking space. The driver operates the brake, accelerator or clutch pedal and the shift / selector lever.

The state in which the steering wheel is operated by the system, is referred to as **parking operation**.

The Park Assist is an extension of the parking aid » page 219 and operates on the basis of data collected by the ultrasonic sensors.

For this reason, the chapter on the parking aid is to be read carefully and the safety notes are to be observed.

! WARNING

- The general information relating to the use of assistance systems must be observed » [page 216](#), **!** in section *Introduction*.
- During the parking process, the system automatically performs rapid steering movements. While it is doing so, do not place your hands between the steering wheel – risk of injury!
- During a parking manoeuvre on loose or slippery surfaces (gravel, snow, ice, etc.) you may stray from the calculated road. It is therefore recommended that you do not use the system in such situations.

! CAUTION

The correct evaluation of the parking space and the parking procedure depends on the circumference of the wheels on the vehicle.

- The system only works correctly if the vehicle is fitted with the wheel size approved by ŠKODA AUTO.
- Do not use the system if snow chains or an emergency wheel are fitted.
- If wheels other than those approved by ŠKODA AUTO are fitted, the resulting position of the vehicle in the parking space can differ slightly. This can be avoided by readjusting the system at a specialist garage.

! CAUTION

If other vehicles are parked behind or on the curb, the system can drive your vehicle over the kerb or up to the kerb - there is a risk of damage to the wheels. Intervene in time if necessary.

i Note

- We recommend performing the parking at a safe speed to about 5 km/h.
- The parking procedure can be stopped at any time by pressing the **P** » [Fig. 286](#) on [page 230](#) button or by a steering intervention.

Operation



Fig. 286
System button

📖 **Read and observe **!** and **!** on page 230 first.**

The system support is provided in the following manner.

- ▶ While the parking space search is going on, a measurement and evaluation of the parking space size is completed.
- ▶ The display of the instrument cluster (hereinafter only display) shows suitable parking spaces and a parking mode is recommended.
- ▶ The display shows instructions and information before the start and during the parking.
- ▶ Based on the calculated road surface, the front wheels will be automatically rotated during the parking.

Conditions for the system function

The system can look for a parking space only if the following basic conditions are met.

- ✓ The system is activated.
- ✓ The vehicle is travelling at less than 40 km/h.
- ✓ The vehicle is travelling at less than 20 km/h.
- ✓ The distance to a number of parked vehicles is approximately 0.5 - 1.5 m.
- ✓ TCS is activated » [page 218](#).

The system can only carry out the parking procedure if the following basic conditions are met.

- ✓ The vehicle is travelling at less than 7 km/h.
- ✓ The parking procedure takes less than 6 minutes.
- ✓ There is no driver intervention in the automatic steering operation.
- ✓ TCS is activated » [page 218](#).

- ✓ The TCS does not engage.
- ✓ No trailer or other accessory is connected to the trailer socket.

Activation/deactivation

The system can be activated/deactivated by pressing the **P** button » Fig. 286.

When the system is activated, the **P** symbol illuminates in the button.

Parking space search

Read and observe **!** and **!** on page 230 first.

The system searches for a parking space in a number of parallel and transverse parked vehicles on the passenger or driver's side.

Process with the parking space search

- Slowly drive past a row of parked vehicles.
- Activate the system with the **P** button » Fig. 286 on page 230.

The system will automatically search for a parking space on the passenger side.

If the system finds a parking space, the recommended parking mode is displayed » Fig. 288 on page 232 **A** or » Fig. 289 on page 232 - **A**.

Activate the turn signal on the driver's side if you wish to look for a parking space on this side of the road. The display changes and the system searches for a parking space on the driver's side.

Note

If the symbol  (km / h) is shown in the display while you are looking for a parking space, the vehicle speed should be reduced below 40 km / hr (parallel parking) or below 20 km / hr (Transverse parking).

Switch to park mode

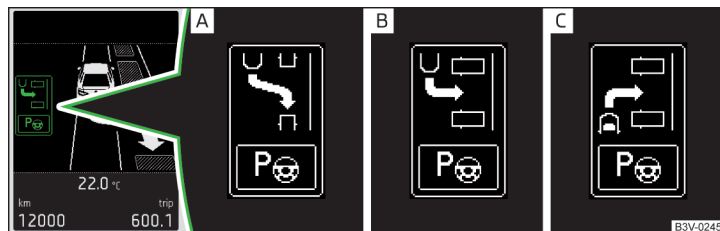

Fig. 287 Menu with the parking modes: Display

Read and observe **!** and **!** on page 230 first.

While the parking space search is going on and before the start of the parking, a menu may appear showing other suitable parking modes.

Parking modes » Fig. 287

- A** To park backwards in a parallel parking space
- B** To park backwards in a transverse parking space
- C** To park forwards in a transverse parking space

The parking mode can be changed by pressing the **P** » Fig. 286 on page 230 button.

After switching through all parking modes offered, an additional press of the **P** button deactivates the system.

If you want to return to the originally recommended parking mode, press the **P** button again.

Parking

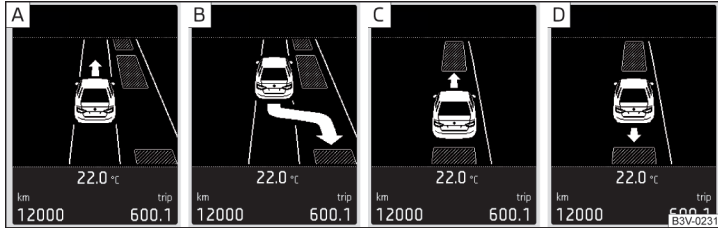

Fig. 288 To park in a parallel parking space: Display

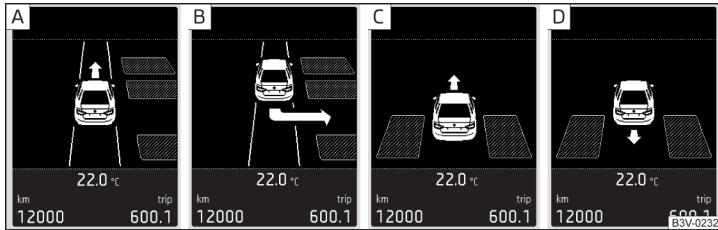

Fig. 289 To park in a traverse parking space: Display

Read and observe and on page 230 first.

The system supports the driver when reverse parking in the parking space found in a number of traverse and parallel parked vehicles.

Display view » Fig. 288 or » Fig. 289

- A** Parking space recognised with the information to drive on
- B** Parking space recognised with the information to reverse
- C** Note to drive on to the parking space
- D** Note to reverse to the parking space

Process for reverse parking

The parking space found is shown in the display » Fig. 288 - **A** or » Fig. 289 - **A**.

A.

- › Continue driving forwards until **B** appears in the display.
- › Stop and ensure that the vehicle does not continue to move forward until the parking procedure starts.
- › Select reverse gear or move the selector lever into position **R**.
- › As soon as the following message is shown in the display: **Steering int. active. Be mindful of your surroundings**, let go of the steering wheel and the steering is taken over by the system.
- › Observe the direct vicinity of the vehicle and reverse carefully.

If necessary, the parking procedure can be continued with further steps.

- › If the arrow in the information display is flashing to the front **C**, engage 1st gear or move the selector lever into the position **D/S**.

The display shows the (brake pedal).

- › Depress the brake pedal and wait until the steering wheel automatically rotates into the required position, the symbol goes out.
- › Carefully drive forwards.
- › If the backwards arrow is flashing in the display - **D**, select reverse gear again or move the selector lever into position **R**.

The display shows the (brake pedal).

- › Depress the brake pedal and wait until the steering wheel automatically rotates into the required position, the symbol goes out.
- › Carefully move backwards.

You can repeat these steps several times in succession.

As soon as the parking procedure is complete, an audible signal sounds and the following message appears in the display.

Parking forwards

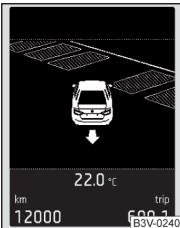

Fig. 290
To park forwards in a traverse parking space: Display

Read and observe **!** and **!** on page 230 first.

The system supports the driver when parking forward in the parking space found in a number parallel parked vehicles.

As soon as the system finds a parking space, select the **P** » Fig. 286 on page 230 button for forwards parking mode » Fig. 287 on page 231 - . The display shows the following » Fig. 290.

The further procedure is analogous to that for reverse parking.

» Follow the system instructions shown in the display.

As soon as the parking procedure is complete, an audible signal sounds and the following message appears in the display.

The system is activated by pressing the **P** button and this is also possible if the vehicle has already been partially moved to a suitable parking space.

Departing from a parallel parking space

Read and observe **!** and **!** on page 230 first.

The system supports the driver when leaving a parking space of a parallel parking space.

Leaving a parking space process

» Press the **P** » Fig. 286 on page 230 button.

The following message is displayed: **Please indicate and engage reverse gear.**

» Activate the turn signal for side of the vehicle where the parking space is out of which you wish to manoeuvre.

» Select reverse gear or move the selector lever into position **R**.

The further procedure is analogous to that for reverse parking.

» Follow the system instructions shown in the display.

As soon as the parking procedure is complete, an audible signal sounds and the following message appears in the display.

If the parking space is too small, it is not possible to use the system to leave the parking space. A corresponding message is shown in the information cluster display.

Automatic brake assist

Read and observe **!** and **!** on page 230 first.

Automatic brake assist when speeding

If a velocity of 7 km / h is exceeded during the parking manoeuvre for the first time, the speed will be automatically reduced by the system to less than 7 km / h. This prevents the parking manoeuvre from aborting.

Automatic emergency braking

If the system detects a risk of collision during parking, automatic emergency braking takes place to prevent a collision.

The parking is terminated by the emergency braking.

! CAUTION

The automatic emergency braking is not triggered by the system when the parking process stops due to the speed of 7 km / hr being exceeded!

Malfuncions

Read and observe **!** and **!** on page 230 first.

If the system is not available, an appropriate message appears in the display of the instrument cluster.

System unavailable

If the system is not available because the vehicle has a fault, a message appears concerning the unavailability. Seek help from a specialist garage.

System fault

In the case of a system fault, an error message appears. Seek help from a specialist garage.

Cruise Control System

Introduction

The Cruise Control System (CCS) maintains a set speed without you having to actuate the accelerator pedal. The state where the CCS maintains the speed is referred to hereinafter as the **control**.

! WARNING

- The general information relating to the use of assistance systems must be observed » page 216, ! in section *Introduction*.
- After pressing the clutch pedal, no interrupted control occurs! For example, if a different gear is engaged and the clutch pedal is released, control is continued.

Operation

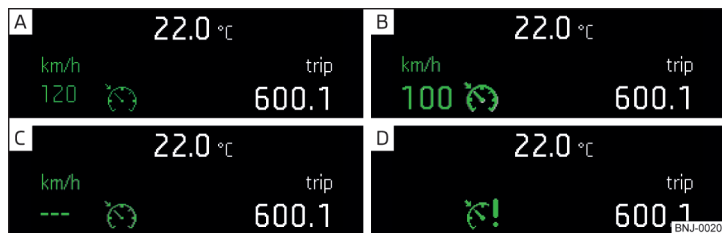

Fig. 291 Instrument cluster display: Examples of status displays the CCS

Read and observe ! on page 234 first.

CCS status displays » Fig. 291

- A Speed is set, control is inactive (in the colour display the digits of speed limits is shown in grey).
- B Control active (in the colour display the digits of the speed limits are highlighted).
- C No speed set.
- D System fault - seek assistance from a specialist garage immediately.

Basic requirements for start of control

- ✓ The CCS is activated.
- ✓ On vehicles with a **manual transmission**, the second gear or higher is engaged.
- ✓ On vehicles with an **automatic transmission**, the selector lever is in the **D/S** position or in the Tiptronic position.
- ✓ The current speed is greater than approx. 20 km/h.

This is only possible within the range which is permitted by the power output and braking power of the engine.

! WARNING

If the engine power and engine braking effect is insufficient in order to maintain the set speed, the acceleration and brake pedals must be taken over!

operation description

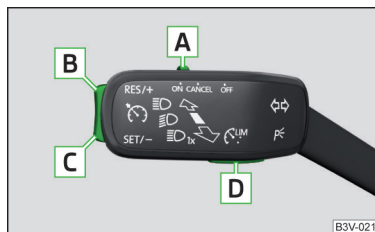

Fig. 292
Cruise control system controls

Read and observe ! on page 234 first.

Overview of the control elements of the CCS » Fig. 292

- A **ON** Activate CCS (regulation deactivated)
- CANCEL** Interrupt control (sprung position)
- OFF** Deactivate CCS (delete set speed)
- B **RES/+** Take control again^{a)} / Increase speed
- C **SET/-** Launch control / reduce speed
- D **↔** Switching between CCS and speed limiter

^{a)} If no speed is set the current speed is adopted.

After the start of the regulation, the CCS regulates the vehicle to the current speed and the warning light  illuminates in the instrument cluster.

The **automatic control interruption** occurs if any of the following conditions are met.

- ▶ The brake pedal is operated.
- ▶ When one of the brake assist systems (e.g. ESC) intervenes.
- ▶ Through an airbag deployment.

! WARNING

- Always deactivate the cruise control system after use to prevent the system being switched on unintentionally.
- The control does not resume if the set speed for the existing traffic conditions is too high.

i Note

- During control, speed can be increased by pressing the accelerator pedal. Releasing the accelerator pedal will cause the speed to drop again to the set speed.
- By pressing the button **[D]** » Fig. 292 during the regulation this is cancelled and the Speed Limiter is activated.

Speed limiter

Introduction

The Speed Limiter limits the maximum driving speed to the set speed limit.

The speed limit can only be exceeded by depressing the accelerator pedal fully.

The condition in which the Speed Limiter prevents a potential set speed limit excess is referred to as **Regulation**.

! WARNING

The general information relating to the use of assistance systems must be observed » page 216, **!** in section *Introduction*.

Function

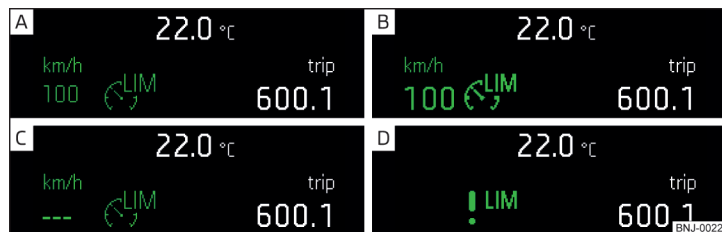

Fig. 293 Instrument cluster display: Examples of Speed Limiter status displays

Read and observe **!** on page 235 first.

Speed limiter status displays » Fig. 293

- [A]** Speed limit is set, control is inactive (in the colour display the digits of speed limits is shown in grey).
- [B]** Control active (in the colour display the digits of the speed limits are high-lighted).
- [C]** No speed limit set.
- [D]** System fault - seek assistance from a specialist garage immediately.

Basic requirements for start of control

- ✓ The Speed Limiter is activated.
- ✓ The current speed is greater than approx. 30 km/h.

After starting the system, the current speed is set as the speed limit, the warning light  lights up in the instrument cluster.

Exceeding the speed limit during the regulation

If, during the control, it is necessary to exceed the speed limit (e.g. to overtake), the accelerator pedal must be pressed fully.

When exceeding the speed limit (e.g. driving down a hill), an acoustic signal sounds and the warning light  flashes in the instrument cluster.

The regulation is resumed once the speed has fallen below the set limit.

Operation description - variant with GRA

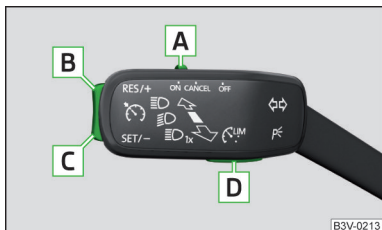

Fig. 294
Operating elements of the speed limiter

Read and observe **I** on page 235 first.

Overview of the control elements of the speed limiter » Fig. 294

- A ON** Activate CCS (required condition for the subsequent activation of the speed limiter)
To activate the speed limiter, set the switch in the position ON and then press button **D**.
- CANCEL** Interrupt control (sprung position)
- OFF** Speed Limiter disable (set limit delete)
- B RES/+** Take control again ^{a)}/ increase speed limit - press (in increments of 1 km/h), hold (in increments of 10 km/h)
- C SET/-** Start control/ reduce speed limit - press (in increments of 1 km/h), hold (in increments of 10 km/h)
- D** Switching between CCS and speed limiter

^{a)} If no speed limit is set, the current speed is set as the speed limit.

i Note

By pressing the button **D** » Fig. 294 during the regulation this is cancelled and the CCS is activated.

Operating Instructions - Variant with ACC

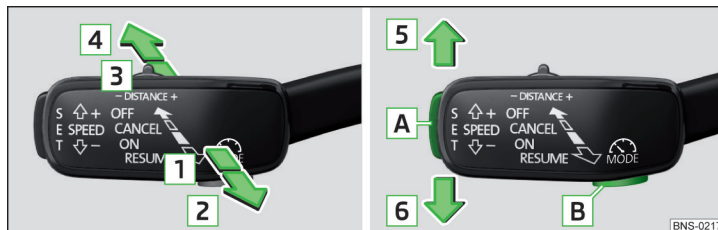

Fig. 295 Controls the speed limiter (variant with ACC)

Read and observe **I** on page 235 first.

Overview of the control elements of the speed limiter » Fig. 295

- 1 ON** Activate ACC (required condition for the subsequent activation of the speed limiter)
To activate the speed limiter, set the lever in the position ON and then press button **B**.
- 2 RESUME** Resume control ^{a)}/ increase speed limit by 1 km/h at a time (sprung position)
- 3 CANCEL** Stop control (sprung position)
- 4 OFF** Disable speed Limiter (delete set limit)
- 5 SPEED +** Increase speed limit by 10 km/h at a time
- 6 SPEED -** Decrease speed limit by 10 km/h at a time
- A SET** Start control / reduce speed limit in increments of 1 km/h
- B MODE** Switching between ACC and speed limiter

^{a)} If no speed limit is set, the current speed is set as the speed limit.

Adaptive Cruise Control (ACC)

i Introduction

The Adaptive Cruise Control (hereinafter referred to as ACC) maintains the set speed and at the same time the distance to the vehicle ahead without the accelerator or brake pedal being pressed. ▶

The front of the vehicle and the distance to the vehicle ahead is monitored by a radar sensor » [page 216](#).

The state in which the ACC maintains the speed or the proximity is described as **control** from here on.

! WARNING

- The general information relating to the use of assistance systems must be observed » [page 216](#), **!** in section *Introduction*.
- The driver must always be ready to take over the operation of the accelerator and brake pedal.
- The ACC does not react when approaching a stationary obstacle, such as traffic jams, vehicle breakdowns or vehicles waiting at a traffic light.
- The ACC does not respond to crossing or oncoming objects.
- If the ACC does not decelerate fast enough, immediately apply the vehicle's foot brake.

! WARNING

- For safety reasons, do not use the ACC under the following conditions.
- When driving in turning lanes, motorway exits or construction sites, to avoid an unwanted acceleration to the stored speed.
 - When visibility is poor, (e.g. fog, heavy rain, thick snowfall).
 - When road conditions are poor (e.g. ice, slippery road, gravel, dirt road).
 - Driving in "sharp" corners or in steep gradients / on steep inclines.
 - When driving through places where metal objects (such as metal buildings, railway tracks, etc.) can be found.
 - When driving through very divided and enclosed spaces (such as large-capacity garages, car ferries, tunnels and the like.).

i Note

- The ACC is designed primarily for use on motorways.
- The ACC reduces the speed by automatically releasing the accelerator or by means of a braking procedure as appropriate. If the brakes are used for an automatic speed reduction at any moments, then the brake light illuminates.
- In case of failure of more than one brake light on the vehicle or on the connected trailer, the ACC becomes unavailable.
- The control automatically cancels the engagement of the brake supportive assistance systems (e.g. ESC) or when the maximum permitted engine speed is exceeded.

Settings in Infotainment

Read and observe **!** on [page 237](#) first.

➤ In the infotainment system, in menu tap on function surface → **Driver assistance**.

- **ACC (adaptive cruise control)** - Setting for the ACC
 - **Driving progr.:** - Adjustment of vehicle acceleration when ACC is activated (this setting is made for vehicles with driving mode selection » [page 244](#))
 - **Last distance selected** - Last selected distance level on/off
 - **Distance:** - Set the distance to the vehicles ahead

Operation

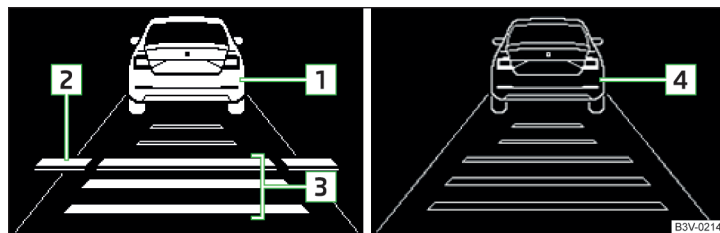

Fig. 296 Instrument cluster display: Examples of ACC displays

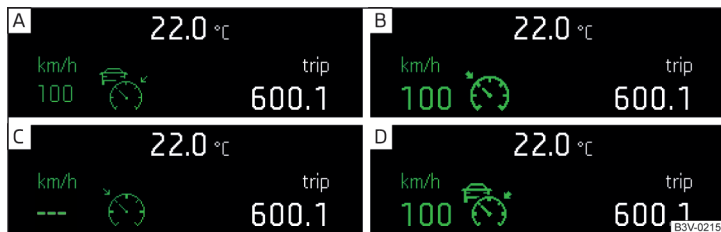

Fig. 297 Instrument cluster display: Examples of ACC status displays

Read and observe on page 237 first.

The ACC makes it possible to set a speed of 30-160 or 30-210 km/h (depending on equipment fitted) as well as the distance to preceding vehicles.

The ACC can detect a vehicle that is up to approx. 150 m ahead using the radar sensor.

ACC displays » Fig. 296

- Vehicle detected (control active)
- Line showing the displacement of the distance when setting » page 240, *Setting the distance*
- Set distance to the vehicle ahead
- Vehicle detected (control deactivated)

Status conditions of the ACC » Fig. 297

- Regulation is inactive (in the colour display the digits of speed limits is shown in grey).
- Regulation active - no vehicle detected (in the colour display the digits of the speed limits are highlighted).
- Regulation deactivated - no speed stored.
- Regulation active - vehicle detected (in the colour display the digits of the speed limits are highlighted).

Note to reduce speed

If the delay of the ACC is insufficient in relation to the vehicle in front, the warning light lights up in the instrument cluster and the display shows a message to engage the brake pedal.

Regulation according to the vehicle in the adjacent lane

During regulation your vehicle may be regulated according to the vehicle in the adjacent lane.

This could occur at speeds above about 80 km/h when your vehicle is moving faster than the vehicle in the adjacent lane on the driver's side. The display shows the detected vehicle is in the adjacent lane.

Note

Some ACC notifications in the display of the instrument cluster may be hidden by notifications for other functions. An ACC notification automatically appears for a brief moment when there is a change in status of the ACC.

Automatic stopping and starting

Read and observe on page 237 first.

Vehicles with an **automatic transmission** can decelerate to a standstill and start moving again using the ACC.

Decelerate to a standstill

If a vehicle ahead decelerates to a standstill, the ACC will also decelerate your vehicle to a standstill.

Starting to drive again after a holding period

As soon as the vehicle ahead starts moving again after a holding period, your vehicle will also move and the speed will continue to be regulated.

If the preceding vehicle starts moving again after a long break, then to continue the regulation press the accelerator pedal or lever to set the lever in **RESUME** » page 239 position.

summary of operations

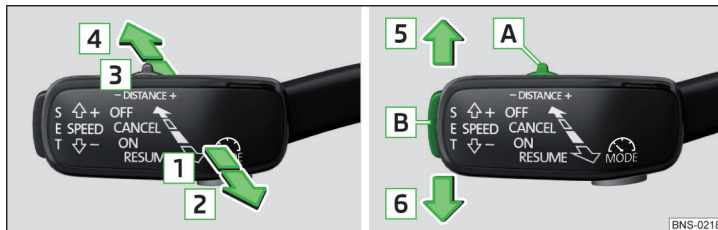

Fig. 298 Operating lever

Read and observe **i** on page 237 first.

Overview of ACC functions operated with the lever » Fig. 298

- 1 ON** Activate ACC (regulation deactivated)
- 2 RESUME** Start control (resume) / increase speed by 1 km/h at a time (sprung position)
- 3 CANCEL** Stop control (sprung position)
- 4 OFF** Deactivate ACC
- 5 SPEED +** Increase speed by 10 km/h at a time
- 6 SPEED -** Decrease speed by 10 km/h at a time
- A - DISTANCE +** Set proximity level
- B SET** Start control / reduce speed in increments of 1 km/h

If the lever is set from the position **OFF** directly into the sprung position **RESUME** the current speed is stored and the control process is started.

Start control

Read and observe **i** on page 237 first.

Basic requirements for start of control

- ✓ The ACC is activated.
- ✓ On vehicles with **manual transmission**, the second gear or a higher gear is selected and the current speed is greater than 30 km/h.
- ✓ On vehicles with **automatic transmission**, the selector lever is in the **D/S** position or in the Tiptronic position.

Start control

- Press the button **SET** » Fig. 298 on page 239 .
- **or:** Set the lever into the sprung position **RESUME** » Fig. 298 on page 239 .

The ACC takes the current driving speed and performs the control, the warning light  illuminates in the instrument cluster.

If the control is started by moving the lever to the position **RESUME** and should the speed be stored already, the ACC adopts this speed and executes control.

i Note

If control is started at a speed of less than 30 km/h on vehicles with an automatic transmission, the speed of 30 km/h is stored. The speed increases automatically to 30 km/h or is regulated with respect to the speed of the vehicle ahead.

Stop/resume control

Read and observe **i** on page 237 first.

Stop control

- Set the lever into the sprung position **CANCEL** » Fig. 298 on page 239 .
- **or:** Apply the brake.

Control stops, the speed remains stored.

Resume control

- Start control » page 239, Start control.

i Note

Control is also stopped when the clutch pedal is held down for longer than 30 s or the TCS is deactivated.

Set/change the desired speed

Read and observe **i** on page 237 first.

The desired speed can be set or changed using the control lever » Fig. 298 on page 239.

Setting/changing the speed by increments of 10 km/h at a time (SPEED) - requirements

✓ The ACC is activated.

Increasing/reducing the speed by increments of 1 km/h at a time (RESUME/SET) - requirements

✓ The ACC is activated.

✓ Vehicle control takes place.

Changing the speed by adopting the current speed (SET) - requirements

✓ The ACC is activated.

✓ The vehicle is moving at a speed **other** than that which is stored.

i Note

■ If during control the speed is increased by pressing the accelerator, control is temporarily stopped. Upon releasing the accelerator, control is automatically resumed.

■ If during control the speed is reduced by applying the brake, control is stopped. Control needs to be restarted in order to resume » page 239.

■ If the vehicle is controlled by a lower speed than the stored speed, then **SET** the current speed is stored by pressing the button again **SET** and the speed is reduced in increments of 1 km/h.

Setting the distance

Read and observe **i** on page 237 first.

The ACC allows you to set five distance steps to the preceding vehicle.

The distance is adjustable in a range of 1 to 3.6 s.

Adjusting the distance in the Infotainment system

› In Infotainment in the ACC the **Distance:** menu item and set the distance » page 237, *Settings in Infotainment.*

Adjust the distance with the lever

› Set the switch **DISTANCE Adjust** in the spring-tensioned position – or + » Fig. 298 on page 239.

The display of the instrument cluster shows line **2** » Fig. 296 on page 237, which indicates the proximity.

› Using the switch **DISTANCE** on the lever, adjust the line **2** to the desired distance.

i Note

■ If the distance is changed in the Infotainment, the change will only come into effect after a subsequent activation of the ACC.

■ The distance setting is stored (depending on Infotainment model) in active user account personalisation » page 55.

Special driving situations

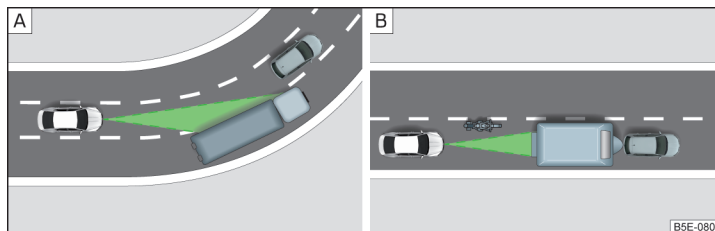

Fig. 299 **Cornering / narrow vehicles or vehicles travelling side by side**

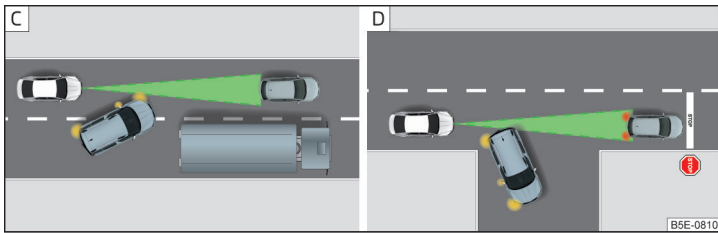

Fig. 300 Lane changes of other vehicles / stationary vehicles

Read and observe **!** on page 237 first.

The following (and similar) situations require special attention and possibly the intervention of the driver (braking, accelerating etc.).

When cornering

When driving into or driving out of long corners, it could be that a vehicle is travelling in the adjacent lane and is scanned by the radar » Fig. 299 - [A]. The host vehicle is then controlled according to this vehicle.

Narrow vehicles or vehicles travelling side by side

A narrow or offset vehicle driving can only be recognized by the ACC if this is located in the scanning range of the radar » Fig. 299 - [B].

Other vehicles changing lanes

Vehicles that change onto the lane with a small distance » Fig. 300 - [C] may not be detected by ACC in good time.

Stationary vehicles

The ACC does not detect stationary objects! When a vehicle detected by the ACC turns or sheers off and there is a stationary vehicle in front of this vehicle, » Fig. 300 - [D] the ACC does not respond to the stationary vehicle.

Vehicles with special load or special body parts

Other vehicles with a load or with body parts protruding from the sides, back or top of the vehicle contour may not be detected by the ACC.

Overtaking and towing

Read and observe **!** on page 237 first.

When overtaking

When your vehicle is being controlled at a speed that is lower than the set speed and the turn signal is operated, ACC assesses this situation as meaning that the driver wishes to overtake. The ACC automatically accelerates the vehicle, thereby reducing the proximity to a vehicle ahead.

If your vehicle changes to the overtaking lane and no vehicle is detected ahead, ACC accelerates until the set speed is reached and then keeps it constant.

Acceleration can be cancelled at any time by touch on the brake pedal or pressing the button **CANCEL** on the lever » Fig. 298 on page 239.

Towing a trailer

When towing, or if another accessory is connected to the trailer socket, ACC control is set with a lower rate. The manner of driving should therefore be adapted to this limitation.

Malfunctions

Read and observe **!** on page 237 first.

If ACC is not available, the warning light  appears in the display of the instrument cluster and an appropriate message is shown.

Sensor covered / dirty

If the sensor cover or the sensor is dirty or covered, a message appears on the instrument cluster display stating there is no sensor view. Clean the sensor cover or remove the obstacles » Fig. 268 on page 216.

If there is no sensor view in the winter, the snow on the sensor under the cover could be the reason. The ACC is functional again after the snow melts away from the sensor.

ACC not available

If the ACC is unavailable, a message concerning the unavailability appears. Stop the vehicle, switch off the engine and then start it again. If ACC continues to be unavailable, seek the assistance of a specialist garage. ▶

ACC fault

With an ACC fault, an error message appears. Seek help from a specialist garage.

Front Assist

Introduction

The Front Assist (hereinafter referred to as the system) warns you of the danger of a collision with a vehicle or another obstacle in front of the vehicle, and tries to avoid a collision or mitigate its consequences by automatically applying the brakes where necessary.

The area in front of the vehicle is monitored by a radar sensor » [page 216](#).

WARNING



- Please take note of the general points relating to the use of assistance systems » [page 216](#),  in section *Introduction*.
- The system does not respond to crossing or oncoming objects.

CAUTION

In case of failure of more than one brake light on the vehicle or on the electrically connected trailer, the system becomes unavailable.

Settings in Infotainment

 **Read and observe  and  on page 242 first.**

- › In the infotainment system, in menu  /  tap on function surface  → **Driver assistance**.
- **Front Assist (ambient traffic monitor. sys.)** - Set the assistant for distance monitoring to the vehicles ahead
 - **Active** - Activate/deactivate the assistant
 - **Advance warning** - Activate/deactivate and set the distance level at which a warning occurs
 - **Display distance warning** - Activate/deactivate distance warnings

Operation

 **Read and observe  and  on page 242 first.**

The system support is provided in the following manner.

- ▶ Alerts you about a dangerous proximity to the vehicle ahead.
- ▶ Warns you of an impending collision.
- ▶ Assists with a brake action triggered by the driver.
- ▶ If the driver fails to respond to a detected danger, an automatic braking action is performed.

The system can work only if the following basic conditions are met.

- ✓ The system is activated.
- ✓ TCS is activated » [page 218](#).
- ✓ The vehicle is travelling forwards at a speed of more than approx. 5 km/h.

Note

The system can be impaired or may not be available, for example when driving in "sharp" curves or with an ESC engagement » [page 217](#).

Distance warning

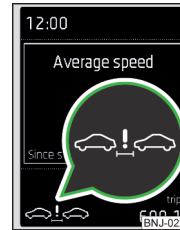



Fig. 301
Instrument cluster display: Distance warning

 **Read and observe  and  on page 242 first.**

If a safe distance from the vehicle ahead is fallen short of, the warning light appears in the display  » [Fig. 301](#).

Immediately increase the proximity if the current traffic situation allows you to do so!

The proximity at which the warning is displayed depends on the current speed. The warning may occur when driving between about 60 km/h and 210 km/h.

Warning and automatic braking



Fig. 302
Instrument cluster display: Advance warning or emergency braking at low speed

📖 Read and observe **!** and **!** on page 242 first.

Emergency braking at low speed

If there is a risk of collision in a vehicle speed range of about 5 km/h to 45 km/h, the system triggers an automatic braking.

With automatic braking, the warning light appears in the display  » Fig. 302.

Advance warning

If the system detects a risk of collision, the warning light appears on the display  » Fig. 302 and an audible signal is emitted.

The pre-warning display can occur in the following situations.

- ▶ If there is a risk of collision with a **moving** obstacle in a speed range of approximately 30 km/h to 210 km/h.
- ▶ If there is a risk of collision with a **stationary** obstacle in a speed range of approximately 30 km/h to 80 km/h.

With a warning the brake pedal must be pressed or the moving obstacle is to be avoided!

Immediate warning and automatic braking - a moving obstacle

If the driver does not react to the advance warning when in danger of a collision with a moving obstacle, the system briefly applies the brake automatically via an active brake intervention to draw attention to the potential danger of a collision again.

If the driver does not respond to acute warning, the system begins to automatically brake the vehicle.

Automatic braking - a stationary obstacle

If the driver does not respond to the advance warning of the risk of a collision with a stationary obstacle in a speed range of approximately 30 km/h to 60 km/h, the system initiates automatic braking.

Information on automatic braking

If an automatic brake intervention is triggered by the system, the pressure in the brake system increases and the brake pedal cannot be operated with the normal pedal stroke.

The automatic braking interventions can be cancelled by pressing the accelerator pedal or by means of a steering intervention.

Brake assist

If the driver brakes inadequate with an impending collision, the system automatically increases braking force.

The braking assistance only occurs as long as the brake pedal is being firmly pressed down.

Disable/enable

📖 Read and observe **!** and **!** on page 242 first.

- ▶ In the instrument cluster display, in the **Assist systems** menu item.
- ▶ In Infotainment, in the **Front Assist (ambient traffic monitor. sys.)** menu, in the **Active** » page 242, **Settings in Infotainment** menu item.

The system is automatically activated each time the ignition is switched on.

The system should only be disabled in exceptional cases » **!**.

! WARNING

In the following situations, Front Assist should be switched off for safety reasons.

- When the vehicle is being towed away.
- When the vehicle is on a rolling test bench.
- If an unfounded warning or a system action was taken.
- When on a truck, or a car ferry service or similar.

Malfunctions

 Read and observe  and  on page 242 first.

If the system is not available, an appropriate message appears in the display of the instrument cluster.

Sensor covered / dirty

If the sensor cover or the sensor is dirty or covered, a message appears on the instrument cluster display stating there is no sensor view. Clean the sensor cover or remove the obstacles » [Fig. 268 on page 216](#).

If there is no sensor view in the winter, the snow on the sensor under the cover could be the reason. The system is functional again after the snow melts away from the sensor.

System unavailable

If the system is unavailable, a message concerning the unavailability appears. Stop the vehicle, switch off the engine and then start it again. If the system still is not available, seek the assistance of a specialist garage.

Select the driving mode (Driving Mode Selection)

Introduction

By selecting the driving mode, the driving behaviour can be adapted to the desired mode of operation.

the following modes **Eco**. **Comfort**. **normal**. **Sports** and **individual** are available.

The **Comfort** mode is only available on vehicles with the adaptive chassis (DCC).

WARNING

Please take note of the general points relating to the use of assistance systems » [page 216](#),  in section *Introduction*.

Adaptive chassis (DCC)

 Read and observe  on page 244 first.

The adaptive chassis (hereafter known as DCC) provides the ability to adjust the shock characteristics for the sporty, normal or comfortable driving when the corresponding control mode is selected.

244 Driving

The DCC evaluates steering response and road conditions while driving continuously and adjusts the suspension behaviour within the selected driving mode accordingly.

mode Eco

 Read and observe  on page 244 first.

This mode is suitable for a relaxed style of driving and helps to save fuel.

Selecting this mode primarily affects the function of the following systems.

Drive

Vehicle acceleration is more relaxed than in **Normal** mode.

The recommended gear is controlled such to achieve the lowest possible fuel consumption » [page 49](#).

If the START-STOP system is deactivated manually » [page 207](#), this will be automatically activated.

The automatic gearbox is set automatically to mode **E** » [page 212](#).

Adaptive Cruise Control (ACC)

Acceleration occurs more relaxed than in **Normal** » [page 236](#) mode with distance control.

Xenon headlight

The system is in economic mode » [page 72](#). The headlamps are in basic setting and do not adapt to the direction of travel.

Air conditioning (Climatronic)

The air conditioning is controlled so as to save energy. For this reason, for example, it may take longer to reach the desired interior temperature in mode **Normal**.

Note

The maximum vehicle acceleration (kick down function) is possible also in driving mode **Eco**.

Mode Comfort

Read and observe **i** on page 244 first.

This mode is suitable for driving on roads with poorer surface or for long motorway journeys.

Mode Normal

Read and observe **i** on page 244 first.

This mode is suitable for a conventional driving.

Mode Sports

Read and observe **i** on page 244 first.

This mode is suitable for a sporty driving.

Selecting this mode primarily affects the function of the following systems.

DCC

The DCC adjusts the chassis for the sporty driving style.

Steering

The power steering is reduced slightly, i.e., the driver needs to exert more force for steering.

Drive

The vehicle acceleration is more dynamic than in **Normal** mode.

Adaptive Cruise Control (ACC)

The acceleration is quicker than in **Normal** mode with distance control
» page 236.

Xenon headlight

The headlamps adapt to the driving style more dynamically than in mode **Normal** » page 72.

ProActive passenger protection

The first level of protection is deactivated » page 246.

Mode individual

Read and observe **i** on page 244 first.

In the mode **Individual** each system can be set independently » page 246, Settings for individualmode.

Mode selection and Infotainment display



Fig. 303 Button for selecting the driving mode / Display in Infotainment screen

Read and observe **i** on page 244 first.

Display of the driving mode menu

» Press the **MODE** » Fig. 303 button.

The following function surfaces are displayed on the Infotainment screen
» Fig. 303.

A Information on setting the currently selected mode
Setting the **Individual** mode

B Driving mode menu

The **driving mode selection** is performed in one of the following ways.

- By repeatedly pressing the button **MODE**.
- By tapping the relevant function surface on the Infotainment screen
» Fig. 303,

After switching the ignition off and on, the **Normal** mode is set. ►

Note

- The currently selected driving mode is displayed in the infotainment system in the status bar next to the symbol .
- The setting for the individual mode is stored in the active personalisation user account » [page 55](#).

Settings for individualmode

 **Read and observe  on page 244 first.**

In the **Individual** mode, the following menu items can be set.

- **DCC:** - Sets the shock characteristics
- **Steering:** - Set the power steering characteristics
- **Drive:** - Sets the drive characteristics
- **ACC:** - sets the vehicle acceleration when adaptive cruise control is activated
- **Dynamic Cornering light:** - Set the characteristics of the Xenon headlights
- **Air conditioning:** - Sets the Climatronic characteristics
- **Reset mode** - Setting for all menu items in the **Individual** mode to **Normal**
 - **Cancel** - Keep the current settings
 - **Reset** - cancels all menu items in the **Normal** mode

Proactive occupant protection (Crew Protect Assist)

Introduction

ProActive passenger protection (following known as system) increases passenger protection in the front seats in situations that could lead to vehicle impact or overturning.

WARNING

Please take note of the general points relating to the use of assistance systems » [page 216](#),  in section *Introduction*.

Note

- The system component service life is monitored electronically. Further information » [page 42](#),  *Safety systems*.
- If the front passenger front airbag is deactivated, the belt tensioning function for the front passenger seat is switched off.

Function

 **Read and observe  on page 246 first.**

In critical driving situations (e.g. during emergency braking or a sudden change in direction), the following steps can be taken separately or combined in order to reduce the risk of serious injury.

- ▶ The front passenger's and driver's seatbelts, if worn, are automatically **tensioned** closely over the body.
- ▶ Opened electrically powered door windows are closed automatically up to a gap of about 5 cm from the edge.
- ▶ The sliding/tilting roof is closed.

Once the critical driving situation has passed, the tension on the seatbelts will be released again.

The system operates at two levels of protection.

The first level of protection

The system already intervenes in situations that may occur during dynamic driving. As a result, this primarily helps to keep the driver and the passenger in the correct seated position.

The first protection level can be deactivated in one of the following ways.

- ▶ In the infotainment system, in menu  /  tap on function surface  → **Driver assistance**.
- ▶ Deactivating the TCS » [page 218](#).
- ▶ By selecting the driving mode **Sport** » [page 245](#).

After switching the ignition off and on, the system is activated in both levels of protection.

The second level of protection

The system intervenes only if the situation is evaluated as critical, such as when panic braking at high speeds.

This level of protection cannot be deactivated.

Vehicles with the Front Assist system

Using this information, a system intervention may also occur when there is the danger of a collision with an obstacle detected in front of the vehicle.

Spurhalteassistent (Lane Assist)

Introduction



Fig. 304
Sensor for Lane Assist

The lane departure warning (following known as system) helps to keep the vehicle between the boundary lines of a lane.

The system recognises the boundary lines of the lane using a sensor » Fig. 304.

When the vehicle approaches a detected line between lanes, the system makes a **light** movement of the steering wheel in the opposite direction to the boundary line. This corrective steering intervention can be manually overridden at any time.

! WARNING

- Please take note of the general points relating to the use of assistance systems » page 216, ! in section *Introduction*.
- Lane Assist can help you keep the vehicle within the lane. However, it does not steer the vehicle for you. The driver retains full responsibility for steering at all times.
- Some objects or markings on the road can be recognised as the boundary lines - an erroneous steering intervention may be the result.

! WARNING

- The system may not be able to recognise the boundary line, or recognise it incorrectly, for example, in the following situations.
- When visibility is poor, (e.g. fog, heavy rain, thick snowfall).
 - When driving in “sharp” bends.
 - The sensor is blinded by the sun or oncoming traffic.
 - The field of view of the sensor is limited by an obstacle or a preceding vehicle.

! CAUTION

Do not attach any stickers or similar objects in front of the sensor on the windscreen to avoid impairing the functions of the system.

i Note

- The system is designed for driving on motorways and roads with adequate longitudinal markings.
- The system can detect both continuous and broken lines.

Settings in Infotainment

Read and observe ! and ! on page 247 first.

► In the infotainment system, in menu / tap on function surface → **Driver assistance**.

- **Lane Assist (lane departure warning system)** - Settings for Lane Assist
 - **Active** - Activate/deactivate the assistant
 - **Adaptive lane guidance** - Activate/deactivate adaptive lane guidance

Operation

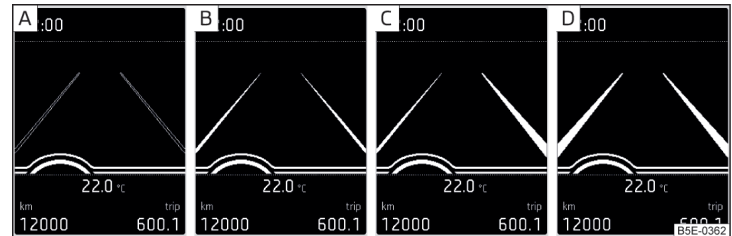

Fig. 305 Monochromatic display of the instrument cluster: Examples of system indications

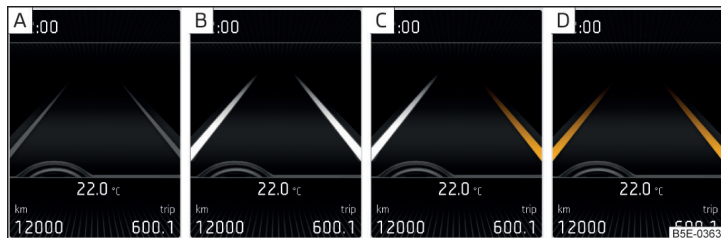

Fig. 306 Colour display of the instrument cluster: Examples of system indications

📖 Read and observe **!** and **!** on page 247 first.

System displays » Fig. 305 and » Fig. 306

- A** The system is active, but not ready to intervene.
- B** The system is active and ready to intervene.
- C** The system intervenes when approaching the right-hand boundary lane.
- D** Adaptive tracking takes place.

The system can intervene when the following basic conditions are present.

- ✓ The system is activated.
- ✓ The vehicle speed is higher than about 65 km/h (not applicable to vehicles with the traffic jam assistant » page 249).
- ✓ The boundary line of at least one side of the lane is detected.
- ✓ The driver's hands are on the steering wheel.
- ✓ The lane is more than 2.5 m in width.

If the turn signal is switched on (e.g. when turning), no steering intervention takes place when the vehicle approaches the boundary line. The system regards the situation as an intended lane change.

Warning lights in the instrument cluster

- !/\ The system is active, but not ready to intervene.
- !/\ The system is active and ready to intervene or is currently intervening.

Adaptive lane assist

Adaptive tracking helps to keep the vehicle in the position between the boundary lines selected by the driver, by means of steering intervention.

If the position within the lane is changed, the system quickly adapts and holds the newly-selected position.

Steering wheel vibrations

In the following situations, it may occasionally be the case that due to the steering wheel vibrations the syst4em indicates that a driver steering intervention is required.

- ▶ The system is not able to keep the vehicle by a within the lane due to a steering intervention.
- ▶ During an intense system-related steering intervention, the system suddenly cannot recognize the boundary lines.

! WARNING

The system function may be restricted if, for example there is danger due to ruts on a downhill road or in a crosswind.

Activation / deactivation

📖 Read and observe **!** and **!** on page 247 first.

The activation/deactivation of the system can be carried out in one of two ways.

- ▶ In the instrument cluster display » page 54, Assist systems menu item.
- ▶ In Infotainment » page 247, Settings in Infotainment.

Adaptive tracking can also be enabled or disabled In Infotainment.

After switching off and switching on the ignition, the system setting is retained.

i Note

The system setting is stored (depending on the Infotainment type) in the active user account personalisation » page 55.

Malfunctions

📖 Read and observe **!** and **!** on page 247 first.

If the system is not available, an appropriate message appears in the display of the instrument cluster. ▶

Sensor covered / dirty

If the windscreen is dirty, iced or misted up in the sensor area, a message appears indicating that there is no sensor view. Clean the windscreen or remove the obstacles from the sensor area.

System unavailable

If the system is unavailable, a message concerning the unavailability appears. Try to re-activate the machine. If the system still is not available, seek the assistance of a specialist garage.

System fault

In the case of a system fault, an error message appears. Seek help from a specialist garage.

Request to take over steering

If the system detects that there are no hands on the steering wheel, this will not work properly. You will be prompted to take over steering. Place your hands on the steering wheel.

Traffic jam assistant

Introduction

! WARNING

- Please take note of the general points relating to the use of assistance systems » page 216, ! in section *Introduction*.
- The driver must always have hands on the steering wheel and be ready to take over steering of the vehicle himself (accelerate or brake).

i Note

The system is designed primarily for use on motorways.

Function

 **Read and observe ! on page 249 first.**

The traffic jam assistant (referred to as system) helps to keep the vehicle within the lane at speeds below 65 km/h while keeping the distance to the vehicle ahead.

Only vehicles with automatic transmission, Lane Assist and ACC can be equipped with the system.

The traffic jam assistant works using the functions of the Lane Assist systems » page 247 and ACC » page 236. For this reason, the chapters relating to these systems must be read carefully and the safety instructions listed therein must be observed.

Operating conditions

 **Read and observe ! on page 249 first.**

The system activation occurs automatically whilst fulfilling the following basic conditions.

- ✓ Lane Assist with the adaptive tracking is enabled, the boundary lines on both sides are recognized lane » page 247.
- ✓ ACC is activated and the regulation » page 236 follows.
- ✓ The vehicle speed is below 65 km/h.

Assistant for emergencies

Introduction

! WARNING

- Please take note of the general points relating to the use of assistance systems » page 216, ! in section *Introduction*.
- The system is intended for emergency situations when the driver is suddenly unable to take over the steering task. Therefore, never try to test out the system - there is a risk of an accident!

Function

 **Read and observe ! on page 249 first.**

The assistant for emergencies (following known as system) detects inactivity of the driver, which for example can be caused by a sudden loss of consciousness. The system then performs measures as safely as possible to decelerate the vehicle to a stop.

Only vehicles with automatic transmission, Lane Assist and ACC can be equipped with the system. ▶

The Emergency Situation assistant works using the functions of the Lane Assist systems » [page 247](#) and ACC » [page 236](#). For this reason, the chapters relating to these systems must be read carefully and the safety instructions listed therein must be observed.

System intervention

If the system detects the driver's inactivity, it draws attention to this fact by a beep and a message on the display of the instrument cluster. It keeps the vehicle in its lane.

If the driver does not take over the steering even after a repeated warning, the system automatically brakes the vehicle and after it has come to a standstill the parking brake switch on.

With automatic braking, the hazard warning system is switched on.

The automatic braking interventions can be cancelled by pressing the accelerator pedal or by means of a steering intervention.

Operating conditions

 **Read and observe  on page 249 first.**

The system can intervene when the following basic conditions are present.



- ✓ Lane Assist is activated and the limiting lines on the two lane sides are recognised » [page 247](#).
- ✓ ACC is activated and the regulation » [page 236](#) follows.

Traffic sign recognition

Introduction

The traffic sign recognition (following known as system) shows certain traffic signs (e.g. speed limits) on the display of the instrument cluster and if necessary warns against excessive speeds.

WARNING

- Please take note of the general points relating to the use of assistance systems » [page 216](#),  in section *Introduction*.
- Vertical traffic signs must always take precedence over the traffic signs shown in the display. The driver is always responsible for correctly assessing the traffic situation.
- The speed indications in the traffic signs shown refer to the speed units that are common in the country. For example, the display  may relate to km/h or mph depending on the country in question.

WARNING

The traffic signs may not be displayed or displayed incorrectly in the system e.g. in the following situations.



- When visibility is poor, (e.g. fog, heavy rain, thick snowfall).
- The sensor is blinded by the sun or oncoming traffic.
- The field of view of the sensor is limited by an obstacle or a preceding vehicle.
- Travelling at high speed.
- The traffic signs are covered (e.g. by trees, snow or dirt).
- The traffic signs are not standard (round with a red border) or are damaged.
- The traffic signs are attached to flashing neon signs.
- The traffic signs were changed (the navigation data are out of date).

Note

The system is only available in some countries.

Settings in Infotainment

 **Read and observe  on page 250 first.**

- In the infotainment system, in menu  tap on function surface  → **Driver assistance**.
- **Dynamic Road Sign Display** - Settings for the Dynamic Road Sign Display
 - **Show in instrument cluster** - Activation/deactivation of the additional traffic signs in the display of the instrument cluster
 - **Speed warning:** - Configures a warning when the speed limit is exceeded
 - **Warning at over** - Setting warning timing with the option to exceed the speed limit in a range from 0 to 20 km / h

- **Trailer recognition**
 - **Show road signs relevant to trailers** - Activating / deactivating the display of road signs relevant to trailers
 - **Use for route calculation** - Activation / deactivation of taking the trailer into account for route calculation in navigation
 - **Maximum speed for trailer** - Set the top speed for towing a trailer

Operation



Fig. 307
Sensor for Dynamic Road Sign Display

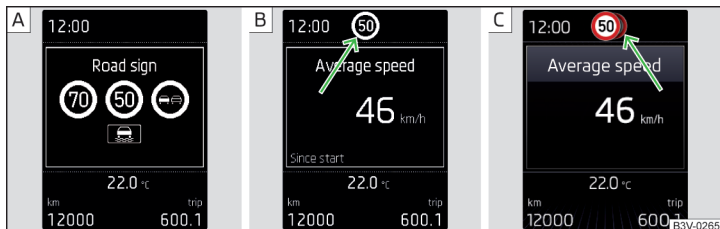

Fig. 308 Instrument cluster display: Display examples

📖 Read and observe **i** on page 250 first.

Description of indications and displayed traffic signs

Display » Fig. 308

- [A] Display of detected road signs » page 51, *Driving data (Multifunction display)*
- [B] Additional display (monochromatic display)
- [C] Additional display (colour display)

The system can display the following (vertical) traffic signs where identified.

- ▶ Speed limit.
- ▶ Overtaking prohibited.

Additional signs, such as 'when wet' or signs which only apply for a limited time can also be displayed.

The system displays only traffic signs that are in the "viewing area" of the sensor » Fig. 307.

Data from the sensor is supplemented by information from the Infotainment Navigation. This is the reason why traffic signs with maximum speeds can also be shown on sections of roads which do not have any traffic signs.

Warning when exceeding the speed limit

The warning when exceeding the permissible speed (based on the detected traffic sign) can be activated and set in Infotainment» page 250.

Mode when towing a trailer

For vehicles with a factory-fitted towing device, in the Infotainment it is possible to enable or disable the relevant traffic signs for trailer operation and the top speed for towing a trailer » page 250, *Settings in Infotainment*.

i Note

If, for example, you are on a motorway without speed limits, then a road sign relating to the end of all limits is shown in the instrument cluster display.

Additional display

📖 Read and observe **i** on page 250 first.

If the menu item Road sign is currently not shown » Fig. 308 on page 251 - [A], the road sign with the speed limit will appear in the upper display area of the instrument cluster » Fig. 308 on page 251 - [B], [C].

If several traffic signs are detected simultaneously, in some cases the next traffic sign will also be displayed in the colour display - » Fig. 308 on page 251 - [C].

All detected traffic signs can be displayed via the multifunction display in the menu item Traffic Sign Recognition » Fig. 308 on page 251 - [A].

This additional function can be activated/deactivated in Infotainment » page 250.

i Note

The setting (activation/deactivation) of the auxiliary display will be saved (depending on the Infotainment type) in the active user account personalisation » [page 55](#).

Malfunction and information messages

 **Read and observe  on page 250 first.**

If the system is not available, an appropriate message appears in the display of the instrument cluster.

Sensor dirty/covered

If a note appears in relation to the cleaning of the windscreen, clean the windscreen or remove the obstruction from the sensor area.

System fault

If an error message appears, seek assistance from a specialist garage.

System limitation

The system displays a message about system limitation in the following cases.

- ▶ The map documents are not up to date.
- ▶ The vehicle is located in an area for which no map documents are present.

Fatigue detection system



The fatigue detection system (hereinafter simply the system) advises the driver to take a break from driving when driver fatigue can be detected based on the driver's steering behaviour.

The system evaluates the steering behaviour at speeds of 60-200 km/h.

Conditions under which a break from driving is detected by the system

- ▶ The vehicle is stopped and the ignition switched off.
- ▶ The vehicle is stopped, the seat belt removed and the driver's door opened.
- ▶ The vehicle is stopped for more than 15 minutes.

If none of these conditions are met or if the driving style is not changed, the system recommends a driving break again after 15 minutes.

The system can be activated/deactivated in menu   →  → **Driver assistance menu**.

Pause recommendation

The icon appears and the following message for a few seconds in the display of the instrument cluster  and a message about detected fatigue. An audible signal is also emitted.

WARNING

- Please take note of the general points relating to the use of assistance systems » [page 216](#),  in section *Introduction*.
- For the driving ability is always the driver's responsibility. Never drive if you feel tired.
- The system may not detect all cases where a break is needed.
- Therefore, take regular, sufficient breaks during long trips.
- There will be no system warning during the so-called micro-sleep.

i Note

- In some situations, the system can evaluate the steering behaviour incorrectly and therefore falsely display a break recommendation.
- The system is designed primarily for use on motorways.

Tyre pressure monitoring

Introduction

The tyre pressure monitoring function (following known as system) monitors the tyre pressure while driving.

If the tyre inflation pressure changes, the warning light  lights up in the instrument cluster and an audible signal sounds» [page 43](#).

The system can only function properly if the tyres have the prescribed inflation pressure and these pressure values are stored in the system.

Always save the tyre pressure values in the system if one of the following events occurs.

- ▶ Change of tyre pressure values.
- ▶ Change one or more wheels.
- ▶ Change in position of a wheel on the vehicle.
- ▶ The warning light  in the instrument cluster. ▶

! WARNING

- Please take note of the general points relating to the use of assistance systems » page 216, ! in section *Introduction*.
- Having the correct tyre inflation pressure is always the driver's responsibility. Tyre pressure should be checked regularly » page 277.
- The system cannot warn in case of very rapid tyre inflation pressure loss, e.g. in case of sudden tyre damage.
- Before storing the pressures, the tyres must be inflated to the specified inflation pressure » page 277. If the wrong pressure values are stored, the system may not issue any warnings, even if the tyre pressure is too low.

! CAUTION

To ensure proper system function, the tyre pressure values must be stored every 10 000 km or 1x a year.

Storing the tyre pressure values and Infotainment display

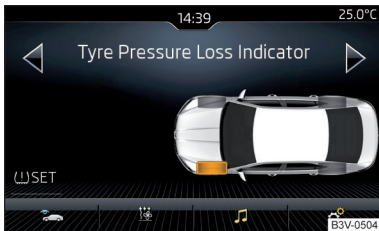

Fig. 309
Button for storage / screen display example: a tyre pressure change at the front left is shown

📖 Read and observe ! and ! on page 253 first.

Procedure for storing the tyre pressure values

- Inflate all the tyres to the specified pressure.
- Turn on the ignition and switch on Infotainment.
- In the infotainment system, in menu **CAR** / **☰** tap on function surface **🚗** Tap → **Vehicle status**.
- Use the function surfaces **<** **>** select the *Tyre Pressure Loss Indicator* menu item.
- Tap the functional surface **(L) SET** interface » Fig. 309.

In addition, follow the instructions that appear on the screen.

A message on the screen informs about the storage of the tyre pressure values.

i Note

When the warning light **(L)** appears in the instrument cluster, the affected tyre can be displayed on the infotainment system » Fig. 309.

Towing device and trailer

Hitch

Introduction

The maximum trailer load is dependent on the engine and the vehicle equipment. The valid specification for your vehicle can be found in the technical vehicle documentation, (e.g. vehicle approval documentation, the COC document) or at a ŠKODA partner.

Other data (e.g. shown on the rating plate of the hitch) only provides information about the test values of the device.

! WARNING

Do not use the towing device if it is damaged or if there are parts missing.

Swinging in and out the tow bar



Fig. 310 Ball rod: Swivel out/in

Read and observe ! on page 254 first.

The pivotable tow bar cannot be removed. Its correct latching in both positions is indicated by a warning light.

Swing out the tow bar

► Pull the release lever **A** in the direction of arrow **1** » Fig. 310 » !. The tow bar pivots in the direction of arrow **2** and the warning light beside the handle **flashes red**.

- Allow the handle **A** to retract slowly and check if this is properly seated in the starting position.
- Press the tow bar in the direction of the arrow **2**, until it audibly clicks into place. The warning light **lights green**.

Swivel tow bar

No trailer or other accessory is connected to the tow bar. A socket or adapter may not be plugged into the 13-pin socket.

- Pull the release lever **A** in the direction of arrow **1** » Fig. 310. The tow bar is unlocked and the warning light beside the handle **flashes red**.
- Allow the handle **A** to retract slowly and check if this is properly seated in the starting position.
- Swing in the tow bar under the bumper in the direction of arrow **3** until it clicks into place. The warning light **lights green**.

Check latching

If the tow bar is incorrectly locked, the warning light flashes red, after the ignition is switched on an acoustic signal is sounded and the following message appears in the instrument cluster.

! WARNING

- Take care with the towing device - it may cause injury.
- When swinging out the ball rod away from the central area of the rear bumper, there is a danger of injury to the legs.
- Do not manipulate the release lever as long as a trailer or another accessory is coupled to the tow bar. The tow bar could come loose - risk of accident and injury.
- If the warning light does not turn green, or the tow bar cannot engage, then do not use the tow bar. Seek help from a specialist garage.

i Note

When not using the towing device, always swing the tow bar under the bumper.

Vertical load with mounted accessories

Read and observe ! on page 254 first.

When using the accessories (e.g. bicycle carrier), the maximum length and the permissible total weight including load must be considered. ►

The **maximum length** of the mounted accessories (from the ball of the towing device) may not exceed **70 cm**.

The **permissible total weight** of mounted accessories including their load may not exceed 75 kg.

This value applies if the center of gravity is at a distance of no more than 30 cm from the towing device ball head.

If the distance of the centre gravity of the load to the ball head of the towing device is greater than 30 cm, then the max. permissible total weight of the accessory, including its load, decreases (e.g. at a distance of 60 cm from the ball head, the permissible weight decreases by half).

! CAUTION

Never exceed the permissible **total weight** of the accessories incl. load and **maximum length** of the accessories – There is a risk of damage to the towing device.

i Note

We recommend that you use accessories from ŠKODA Original Accessories.

Using hitch

Trailer (accessory) connect and disconnect

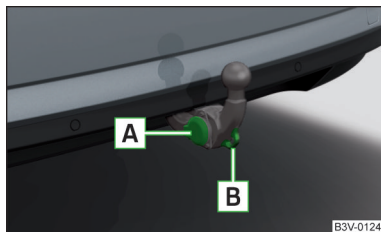

Fig. 311
Housing of the 13 pin socket,
safety eyelet

Connect / disconnect

- › Swing out the tow bar » [page 254](#).
- › Place the trailer (the accessory) onto the ball head.

- › Open the socket cap and insert the plug of the trailer (accessories) into the 13-pin socket **A** » [Fig. 311](#). (If the trailer / accessories have a 7-pin connector, use a corresponding adapter from the ŠKODA Original Accessories).
- › Suspend the breakaway cable of the trailer at the safety eyelet **B** (the breakaway cable must **sag** in all trailer settings in view of the vehicle).

Uncoupling takes place in reverse order.

Exterior mirrors

You should have additional exterior mirrors fitted if you are not able to see the traffic behind the trailer using the standard rear-view mirrors.

Headlights

The front of the vehicle may lift up when a trailer (accessory) is being towed and the headlights may dazzle other road users. Set the range of the headlights » [page 70, Operating the lights^{1\)}](#).

Power supply of the trailer / accessory power system

In the electrical connection between the vehicle and trailer (accessory), the trailer (accessories) is supplied with power from the vehicle (with ignition switched on and off).

With the engine switched off, the vehicle battery is discharged by the connected consumers.

At low charge state of the vehicle battery, the power supply to the trailer (accessories) is interrupted.

! WARNING

- An improperly connected electrical installation of the trailer (accessories) may result in an accident or serious injury from electrical shock.
- Do not make any adjustments to the electrical installation of the vehicle and the trailer (accessories) - risk of an accident or serious injury from electrical shock.
- After the electrical connection between the vehicle and trailer (accessory) the trailer / accessory lights should be checked for function.
- Never use the securing eye to tow - risk of accident!

¹⁾ Applies to vehicles with xenon headlights.

! CAUTION

- An improperly connected electrical installation of the trailer (accessories) can lead to the inoperability of the vehicle electronics.
- The total power consumption of all the connected loads to the trailer power supply must not exceed 350 watts, otherwise there is a risk of damage to the electrical system of the vehicle.

Loading a trailer

Correct the **tyre inflation pressure** on the vehicle for "full load" » [page 277](#).

Distribution of the cargo

Distribute the cargo in the trailer in such a way that heavy items are located as close to the trailer axle as possible. Secure the load from slipping.

Trailer

The details given in the vehicle's technical documentation always take precedence over the details in the Owner's Manual.

The distribution of the weight is very poor if your vehicle is unladen and the trailer is laden. Drive with particular caution if you cannot avoid driving with this combination.

! WARNING

Sliding cargo can significantly adversely affect stability and driving safety - risk of accident!

The permissible trailer load must not be exceeded under any circumstances.

Permissible trailer load - Superb

Engine	Transmission	Permissible trailer weight, braked (kg) at gradients up to 12%.	Permissible trailer load, unbraked (kg)
1.4 l/110 kW TSI	MG	1600	710
	DSG	1600	720
1.5 l/110 kW TSI	MG	1600	720
	DSG	1600	730
1.8 ltr./132 kW TSI	DSG	1800	740
2.0 l/162 kW TSI	DSG	2000	750
2.0 l/200 kW TSI	DSG 4x4	2200	750
2.0 l/206 kW TSI	DSG 4x4	2200	750
1.6 l/88 kW TDI CR	MG	1500	750
	DSG	1500	750
2.0 ltr./110 kW TDI CR	MG	2000	750
	DSG	2000	750
2.0 ltr./130 kW TDI CR	DSG	2000	750

Engine	Transmission	Permissible trailer weight, braked (kg) at gradients up to 12%.	Permissible trailer load, unbraked (kg)
2.0 ltr./140 kW TDI CR	DSG	2000	750
	DSG 4x4	2200	750

Permissible trailer load - Superb Estate

Engine	Transmission	Permissible trailer weight, braked (kg) at gradients up to 12%.	Permissible trailer load, unbraked (kg)
1.4 l/110 kW TSI	MG	1600	720
	DSG	1600	730
1.5 l/110 kW TSI	MG	1600	720
	DSG	1600	730
1.8 ltr./132 kW TSI	DSG	1800	750
2.0 l/162 kW TSI	DSG	2000	750
2.0 l/200 kW TSI	DSG 4x4	2200	750
2.0 l/206 kW TSI	DSG 4x4	2200	750
1.6 l/88 kW TDI CR	MG	1500	750
	DSG	1500	750
2.0 ltr./110 kW TDI CR	MG	2000	750
	DSG	2000	750
2.0 ltr./130 kW TDI CR	DSG	2000	750
2.0 ltr./140 kW TDI CR	DSG	2000	750
	DSG 4x4	2200	750

! WARNING

The maximum vertical load and the maximum trailer load must not be exceeded - there is risk of accident!

Towing a trailer

Driving speed

For safety reasons, do not drive faster than 100 km/h when towing a trailer.

Immediately reduce your speed as soon as even the slightest swaying of the trailer is detected. Never attempt to stop the trailer from "swaying" by accelerating.

Brakes

Apply the brakes in good time! If the trailer is fitted with a **trailer brake**, apply the brakes gently at first, then brake firmly. This will avoid brake jolts resulting from the trailer wheels locking.

On downhill sections shift down a gear in good time to also use the engine as a brake.

! WARNING

Always drive particularly carefully with the trailer.

! CAUTION

With frequent towing, the vehicle is excessively loaded so this must also be checked between service intervals.

Anti-theft alarm system

The alarm is triggered if, with a vehicle with activated anti-theft alarm (hereinafter only warning system), the electrical connection to the trailer (accessory) is interrupted.

Always switch off the anti-theft alarm system before a trailer (accessory) is coupled or uncoupled » [page 62](#).

Conditions for including a trailer (accessory) in the anti-theft alarm system.

- ✓ The vehicle is factory-fitted with an anti-theft alarm system and a towing device.
- ✓ The trailer (accessory) is electrically connected to the towing vehicle by means of the trailer socket.
- ✓ The electrical system of the vehicle and trailer (accessory) is functional.
- ✓ The vehicle is locked and the anti-theft alarm system is activated.
- ✓ The trailer (accessory) is not equipped with LED taillights.

General Maintenance

Care and maintenance

Service work, adjustments and technical alterations

Introduction

The instructions and guidelines from ŠKODA AUTO must be observed when carrying out any modifications, repairs or technical alterations to your vehicle.

Adhering to these instructions and guidelines helps ensure road safety and helps keep your vehicle in a good technical condition.

WARNING

- Adjustments, repairs and technical changes to the vehicle are to be carried out only by a specialist garage. Improperly conducted work (including work on the electronic components and their software) can cause faults - there is a risk of accidents and increased wear on parts!
- We advise you only to use ŠKODA Original Accessories and ŠKODA Original Parts which have been expressly approved for use on your vehicle. Reliability, safety and suitability for your vehicle are guaranteed with these.
- ŠKODA AUTO cannot assume any liability for products which have not been approved by ŠKODA even though these may be products with a type approval or have been approved by a nationally recognised testing laboratory.

Vehicle operating under different weather conditions

 Read and observe  on page 259 first.

If you would like to operate your vehicle in countries other than those with the intended weather conditions, you should contact a ŠKODA partner. They will advise you if certain precautions need to be taken to ensure the full functioning of the vehicle or to prevent damage (e.g. coolant / battery replacement etc.).

ŠKODA Service Partner

 Read and observe  on page 259 first.

All ŠKODA Service Partners operate according to the most recent guidelines and instructions from ŠKODA AUTO. All service and repair work is therefore carried out on time and at the appropriate quality. Adhering to these instructions and guidelines helps ensure road safety and helps keep your vehicle in a good technical condition.

We therefore advise you to have all modifications, repairs and technical alterations to your vehicle carried out by a ŠKODA Service Partner.

ŠKODA Original parts

 Read and observe  on page 259 first.

We recommend the use of ŠKODA Original Parts for your vehicle, as these parts are approved by ŠKODA AUTO. These parts correspond exactly to the ŠKODA AUTO regulations and are identical to the parts used in series production.

ŠKODA AUTO is able to warrant the safety, suitability, and long life of these products.

ŠKODA Service Partners are liable for any defects of ŠKODA Genuine Parts for a period of 2 years after sale in accordance with the materials defect liability, unless agreed otherwise in the purchase agreement.

ŠKODA Original accessories

 Read and observe  on page 259 first.

If you wish to fit accessories to your vehicle, you should remember the following.

We recommend that you use ŠKODA Genuine Accessories in your vehicle. ŠKODA AUTO has selected such accessories to ensure that they are reliable, safe and suitable for your particular vehicle. Although we constantly monitor the market, we are not able to assess or vouch for other products, even though in some instances such parts may have operational approval or may have been approved by a nationally recognised testing laboratory. ▶

ŠKODA Service Partners are liable for any defects of ŠKODA Genuine Accessories for a period of 2 years after installation or delivery in accordance with the materials defect liability, unless agreed otherwise in the purchase agreement or any other agreements.

Spoiler

 **Read and observe ! on page 259 first.**

WARNING

If your vehicle is equipped with an original spoiler on the front bumper in combination with the spoiler on the boot lid, the following instructions must be observed - otherwise there is a risk of accidents and serious injuries!

- The vehicle must always be equipped with a spoiler on the front bumper only in combination with the corresponding spoiler on the boot lid.
- This kind of spoiler cannot be left on the front bumper either on its own, in combination with another spoiler not on the luggage compartment lid or in combination with an unsuitable spoiler on the luggage compartment lid.
- We recommend that you consult the ŠKODA Service Partner for any repairs to or replacement, addition or removal of spoilers.
- Improperly conducted work on the spoilers of your vehicle may result in malfunction.

Component protection

 **Read and observe ! on page 259 first.**

Some electronic vehicle components (such as the instrument cluster) are factory-equipped with component protection. This ensures the functional limitation of these components in a non-legitimate installation in another vehicle (e.g. after a theft) or operation outside the vehicle.

Airbags

 **Read and observe ! on page 259 first.**

WARNING

- Modifications, repairs and technical alterations that have been carried out unprofessionally can cause damage and operational faults, and can also seriously impair the effectiveness of the airbag system – risk of accident and fatal injury!
- A change to the vehicle's wheel suspension, including the use of non-approved wheels and tyre combinations, can alter the functioning of the airbag system - risk of accident and fatal injury!

WARNING

- No changes may be made to parts of the airbag system, the front bumper and the body.
- Any work on the airbag system including the installation and removal of system components due to other repair work (e.g. removal of the steering wheel) must only be carried out by a specialist garage.
- Do not manipulate individual parts of the airbag system, as this might result in the airbag being deployed.
- If the airbag is triggered, the airbag system must be exchanged.

WARNING

- The airbag system operates using pressure sensors located in the front doors. For this reason, no adjustments may be carried out to the doors or door panels (e.g. installation of additional loudspeakers). The resulting damage can negatively affect the function of the airbag system - there is a risk of accidents and fatal injuries! The following guidelines must be observed.
- Any work on the front doors and their door panels must be carried out by a specialist garage.
 - Never drive with removed inner door panels or openings in the panels.

Cleaning and care

Introduction

Regular and thorough care retains the value of your vehicle. ▶

When using the care product, always observe the instructions on the packaging. We recommend that you use the preservative from the ŠKODA Original Accessories.

! WARNING

- Vehicle care products may be harmful to your health if not used according to the instructions.
- Always keep the vehicle care products safe from people who are not completely independent, e.g. children - there is a danger of poisoning!

! CAUTION

- Do not use any insect sponges, rough kitchen sponges or similar cleaning products – risk of damaging the paintwork surface.
- Do not use aggressive cleaning agents or chemical solvents - there is a danger of damaging the material that is to be cleaned.

i Note

We recommend that the vehicle is cleaned and cared for by a ŠKODA Service Partner.

Washing the vehicle

 **Read and observe ! and ! on page 261 first.**

The best way to protect your vehicle against harmful environmental influences is frequent washing.

The longer insect residues, bird droppings, road salt and other aggressive deposits remain on the paintwork of your vehicle, the more detrimental their destructive effect can be. High temperatures, such as those caused by intensive sun's rays, accentuate this caustic effect.

It is essential to also thoroughly clean the underside of the vehicle at the end of the winter.

Washing by hand

Wash the vehicle from top to bottom, if necessary, wash using a soft sponge or washing mitt and plenty of water with appropriate detergents. Wash out the sponge or washing glove thoroughly at short intervals.

Use a different sponge for the wheels, door sills and lower vehicle areas.

Give the vehicle a good rinse after washing it and dry it off using a chamois leather.

Automatic car washes

The usual precautionary measures must be taken before washing the vehicle in an automatic car wash system (e.g. closing the windows and the sliding/tilting roof etc.).

If your vehicle is fitted with any particular attached parts, such as a spoiler, roof rack system, two-way radio aerial etc., it is best to consult the operator of the car wash system beforehand.

After an automatic wash with wax treatment, the blades of the wipers should be cleaned with cleaning agents specially designed for the purpose, and then degreased.

Pressure washer

When washing the vehicle with a high-pressure cleaner, the instructions for use of the equipment must be observed. This particularly applies to information with respect to the **pressure** and **spray distance** from the vehicle surface.

! WARNING

- When washing your vehicle in the winter: Water and ice in the braking system can affect the braking efficiency – risk of accident!
- Take care when cleaning the underbody or the inside of the wheel wells - there is a risk of injury on sharp metal parts!

! CAUTION

- Do not wash the vehicle in direct sunlight, do not exert pressure on the body while washing. The temperature of the washing water should be max. 60 °C - otherwise there is a risk of damaging the vehicle paint.
- Before driving through a car wash, fold in the exterior mirrors - there is a risk of damage.

! CAUTION

Washing the vehicle using pressure washers

- Do not wash the foils using pressure washers - there is a risk of damage.
- Do not aim the water jet directly at the lock cylinders or the door or opening joints when washing the vehicle in the winter – there is a risk of freezing. ▶

- During cleaning, always keep a sufficiently large spraying distance in particular from the parking sensors, the reversing camera lens, the external decorative and protective plastic parts (e.g. roof racks, spoilers, protective strips) and other vehicle parts made of non-metallic materials, such as rubber hoses or insulation materials – otherwise there is a risk of damage.
- When washing the vehicle, do not point the water jet directly at the tow bar or the trailer socket - there is a risk of seal damage or washing out the grease.

Caring for the outside of the vehicle

📖 Read and observe  and  on page 261 first.

Vehicle component	Facts of the matter	Remedy
Paint	Spilled fuel	Clear water, cloth, (clean as soon as possible)
	No water droplets form on the paint	Use hard wax (min. twice a year), apply wax to clean and dry body
	Matt paint	Use polish, then preserve (if the polish does not contain any preservative ingredients)
Plastic parts	Soiling	Clear water, cloth / sponge provided for the intended cleaning agent
Chromed and anodised parts	Soiling	Clear water, cloth or cleaning agent provided for this purpose, then polish with a soft dry cloth
Foils	Soiling	soft sponge and mild soap solution ^{a)}
Windows and external mirror glass	Soiling	Wash with clean water and dry using the intended cloth
Headlights/lights	Soiling	soft sponge and mild soap solution ^{a)}
Reversing camera	Soiling	Wash with clean water and dry with a soft cloth
	Snow / ice	Hand brush / de-icer
Door lock cylinder	Snow / ice	De-icer

Vehicle component	Facts of the matter	Remedy
Wiper / wiper blades	Soiling	Glass cleaner, sponge or cloth
Wheels	Soiling	Clear water, then coat with appropriate conservation solution

^{a)} A mild soap solution consisting of 2 tablespoons of natural soap to 1 litre of lukewarm water.

The **jack** is maintenance-free. If necessary, the moving parts of the jack should be lubricated with a suitable lubricant.

The **towing device** is maintenance-free. Coat the ball head of the towing device with a suitable grease whenever necessary.

Protection of hollow spaces

All the hollow spaces on your vehicle which are at risk from corrosion are protected for life by a layer of protective wax applied in the factory.

If any small amount of wax flow out of the cavities at high temperatures, these must be removed with a plastic scraper and the stains cleaned using a petroleum cleaner.

Underbody protection

The underside of your vehicle is already permanently protected by the factory against chemical and mechanical influences.

We recommend having the protective coating underneath the vehicle and the chassis checked — preferably before the beginning of winter and at the end of winter.

Product life of the films

Environmental influences (e.g. sunlight, humidity, air pollution, rockfall) affect the life of the films. Films will age and become brittle – this is entirely normal: this is not a fault.

Sunlight may also affect the strength of the film colour.

When transporting a load on the roof rack (e.g. roof box or similar), there is an increased risk of film damage (e.g. of chipping from the secured load).

CAUTION

■ Vehicle paint

- Damaged areas should be repaired as soon as possible.
- Do not treat painted parts with or hard waxes.

- Do not polish the paintwork in a dusty environment - risk of paint scratches.
- Do not apply any paint care products to door seals or window guides.
- **Plastic parts**
 - Do not use paint care products.
- **Chromed and anodised parts**
 - Do not polish the chrome parts in a dusty environment - risk of surface scratches.

■ Foils

The following instructions must be observed, otherwise there is a risk of foil damage.

- Do not clean with dirty cloths or sponges.
- To remove ice and snow, do not use a scraper or other means.
- Do not polish the foils
- Do not use a pressure washer to clean the foils
- **Rubber seals**
 - Do not treat the door seals and window guides with any products - the protective lacquer layer could be affected.
- **Windows and external mirror glass**
 - Do not clean the inside of the windows with sharp objects - there is a risk of damage to the filaments or glass antenna.
 - Do not use a cloth, which was used to polish the body - this could soil the window and reduce visibility.
- **Headlights/lights**
 - Do not dry off the headlights/lights, do not use sharp objects - there is a risk of damage to the protective coating and subsequent cracking of the headlight glass.
- **Reversing camera**

The following instructions must be observed, otherwise there is a risk of camera damage.

 - Do not remove snow / ice with warm / hot water.
 - To wash, never use a pressure washer or steam jet.
 - For cleaning, do not use abrasive cleaners.
- **Door lock cylinder**
 - Make sure that as little water as possible gets into the locking cylinder when washing the vehicle - there is a risk of freezing the lock cylinder!
- **Wheels**
 - Heavy contamination of the wheels can affect the balance of the wheels - this can result in vibrations and, under some circumstances, can cause premature wear of the steering wheel.

Removing snow and ice from the windscreens



Fig. 312
Installation location of the ice scraper, removing the scraper

📖 **Read and observe** **!** and **!** on page 261 first.

Use a plastic ice scraper for removing snow and ice from the windows and mirrors. This can be on the inside of the fuel filler flap.

- Open the fuel filler flap and slide the scraper in the direction of arrow
» Fig. 312.

! CAUTION

- Move the scraper in one direction only, otherwise there is a risk of damage to the glass surface.
- Do not remove snow / ice on the surface that is soiled (e.g. pea gravel, sand, road salt) - there is a risk of damaging the surface.
- Remove snow / ice carefully, otherwise there is a risk of damaging the labels that have been fitted by the factory.

Read and observe **!** and **!** on page 261 first.

Vehicle component	Facts of the matter	Remedy
Natural leather / Faux leather / Alcantara® / Suede / Fabric	Dust, surface contamination	Vacuum cleaner
	Pollution (fresh)	Water, slightly damp cotton / wool cloth, if necessary, mild soap solution ^{a)} , then wipe with a soft cloth
	Stubborn stains	Specially prepared detergent
	Care (natural leather)	Treat the leather periodically with a suitable leather protector and use a care cream with light blocker and impregnation after each cleaning.
	Care (Alcantara® suede / fabric)	Remove stubborn hairs using a "cleaning glove" Remove pills from materials with a brush
Plastic parts	Soiling	Water, slightly damp cloth or sponge, or cleaning agent provided for this purpose
Windows	Soiling	Wash with clean water and dry using the intended cloth
Covers of electrically heated seats	Soiling	Specially provided cleaning agent
Seat belts » !	Soiling	soft cloth and mild soap solution ^{a)}

^{a)} A mild soap solution consisting of 2 tablespoons of natural soap to 1 litre of lukewarm water.

! WARNING

- Never clean the seat belts chemically as chemical cleaning products could destroy the fabric.
- Air fresheners and scents can be hazardous to health when the temperature inside the vehicle is high.

! CAUTION

- **Natural leather / Faux leather / Alcantara® suede / material**
 - In lengthy periods in bright sunlight, it might be sensible to cover these materials in order to avoid bleaching.
 - Fresh stains (e.g. from pens, lipstick, shoe polish etc.) should be removed as soon as possible.
 - Ensure that no part of the leather is soaked through during cleaning and that no water gets into the seams.
 - Do not clean the roof panelling with a brush – risk of damage to the surface of the panelling.
 - Do not use solvents, floor wax, shoe cream, stain remover or similar agents on Alcantara® suede seat upholstery.
 - Some clothing fabrics (e.g. dark denim) do not have sufficient colour fastness - this may leave evident marks on upholstery. This is not a defect in the fabric.
 - Sharp objects on garments (e.g. zips, rivets, sharp-edged belts) can damage the upholstery fabrics in the vehicle. Such damage cannot be subsequently recognised as a justified complaint.
- **Plastic parts**
 - Do not attach scents or air fresheners to the dashboard – there is a risk of damage to the dashboard.
- **Windows**
 - Do not attach any stickers to the filaments or glass antenna - there is risk of damage.
- **Covers of electrically heated seats**
 - Do not clean with water or other liquids - there is a risk of damage to the heating system.
 - Do not dry by switching on the heating.
- **Seat belts**
 - Allow to dry before rolling up the seat belts.

i Note

During use, the leather and Alcantara® and suede materials may show minor changes (e.g. folds, discolouration).

Inspecting and replenishing

Fuel

Introduction

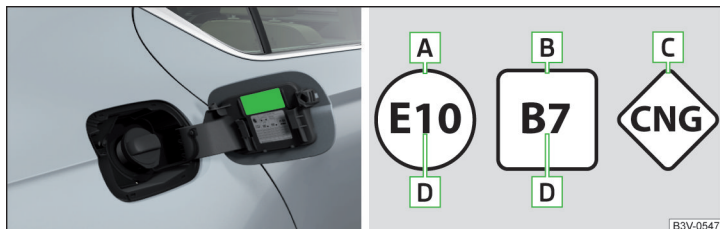

Fig. 313 Label with prescribed fuel / graphic designation of fuel types

The correct fuel for your vehicle is specified on the inside of the fuel filler flap » Fig. 313.

The fuel tank has a capacity of about **66 litres**, including a reserve of approx. **6 litres**.

Graphic name of the fuel types » Fig. 313

- A** Unleaded petrol
- B** Diesel
- C** CNG (compressed natural gas)
- D** Percentage of organic

! WARNING

Fuel vapours are explosive - can be fatal!

! CAUTION

- Never drive until the fuel tank is completely empty! The irregular supply of fuel can cause misfiring, which can result in damage to parts of the engine and the exhaust system.
- Immediately remove any fuel that has spilled onto the vehicle's paintwork – risk of paint damage.
- If you would like to operate your vehicle in countries other than those with the intended weather conditions, please contact a ŠKODA partner. They will tell you whether the fuel specified by the manufacturer is offered in the accompanying country or whether it is permissible to operate the vehicle with another fuel.

Petrol and diesel refuelling



Fig. 314 Open fuel filler flap / unscrew tank cap / place the tank cap on the fuel filler flap



Fig. 315
Fuel filler tube on vehicles with diesel engines

Read and observe **!** and **!** on page 265 first.

Perform the refuelling under the following conditions.

- ✓ The vehicle is unlocked.
- ✓ The ignition is switched off.
- ✓ The auxiliary heating and ventilation is switched off.
- Press the fuel filler flap in direction of arrow **1** and fold in the direction of arrow **2** » Fig. 314.
- Unscrew the tank cap in the direction of arrow **3**.
- Remove the tank cap and place in the recess on top of the fuel filler flap in the direction of arrow **4**.
- Insert the pump nozzle into the fuel filler neck as far as it will go, and refuel.

The fuel tank is full just as soon as the pump nozzle switches off for the first time. Not continue refuelling.

- Remove the pump nozzle from the fuel filler neck and put it back in the pump.
- Place the filler cap onto the fuel filler neck and turn it in the opposite direction to the arrow until it securely engages **3**.
- Close the fuel filler flap until it clicks into place.

Incorrect refuelling guard on vehicles with diesel engines

The fuel filler tube on vehicles with diesel engines has been fitted with an incorrect refuelling guard » Fig. 315.

If the diesel pump nozzle does not sit directly in the fuel filler tube, move it to and fro with slight pressure to insert it correctly.

The diameter of the diesel pump nozzle can be identical to that of the petrol pump nozzle in some countries. When driving in these countries, the incorrect fuelling protection should be removed by a specialist company.

Unleaded petrol

Read and observe **!** and **!** on page 265 first.

The correct fuel for the vehicle is specified on the inside of the fuel filler flap » Fig. 313 on page 265.

The vehicle can only be operated with **unleaded petrol** containing **maximum 10% bioethanol (E10)**.

Unleaded petrol must correspond to the European Standard **EN 228** (in Germany DIN 51626-1 or E10 for unleaded petrol with octane number 95 and 91 or DIN 51626-2 or E5 for unleaded petrol with octane number 95 and 98).

Specified petrol 95 / min. 92 and 93 RON/ROZ

We recommend using petrol **95 RON**.

Optionally, the petrol **92** or **93 RON** can be used (slight power loss, a slightly increased fuel consumption).

In an **emergency** petrol **91 RON** can be used (slight power loss, slightly increased fuel consumption) » **!**.

Unleaded petrol min. 95 RON / ROZ

Use min. **95 ROZ** petrol.

In an **emergency** petrol **91, 92** or **93 RON** can be used (slight loss, a slightly increased fuel consumption) » **!**.

Prescribed petrol 98/(95) RON / ROZ

We recommend using petrol **98 RON**.

Optionally, petrol **95 RON** can be used (slight power loss, a slightly increased fuel consumption).

In an **emergency** petrol **91, 92** or **93 RON** can be used (slight loss, a slightly increased fuel consumption) » **!**.

! CAUTION

The following instructions must be observed, otherwise there is a risk of engine damage and damage to the exhaust system.

- If gasoline is used which is lower than the prescribed octane number, then continue driving at medium engine speeds and minimum engine load. Refuel using petrol of the prescribed octane number as soon as possible.

- Petrol with a **lower** Octane count than **91** should not even be used in an emergency!
- If a fuel other than unleaded fuel which complies to the above mentioned standards (e.g. leaded petrol) is put in the tank by mistake, do not start the engine or switch on the ignition.

CAUTION

Petrol additives (additives)

- The unleaded petrol in accordance with the prescribed standards meets all the conditions for a smooth running engine. Therefore, we recommend that you do not add any fuel additives to the petrol - there is a risk of engine damage or damage to the exhaust system.
- **The following additives and auxiliary products may not be used - there is a risk of engine damage or damage to the exhaust system!**
 - Additives with metal components (metallic additives), in particular with manganese and iron content.
 - Fuels with metallic content (e.g. LRP - lead replacement petrol).

Note

- Unleaded petrol that has a higher octane number than that required by the engine can be used without limitations.
- The use of petrol with an octane rating higher than **95 RON** in does not result in either a noticeable increase in power nor lower fuel consumption in vehicles for which unleaded petrol **95/min 92 or 93 RON** is specified.
- On vehicles using prescribed petrol of **min. 95 RON**, the use of petrol with a higher octane number than **95 RON** can increase the power and reduce fuel consumption.

Diesel fuel

 **Read and observe  and  on page 265 first.**

The correct fuel for the vehicle is specified on the inside of the fuel filler flap
» [Fig. 313 on page 265](#).

The vehicle can only be operated with **diesel fuel** that complies with the European standard **EN 590** (in Germany also DIN 51628, in Austria ÖNORM C 1590, in Russia GOST R 52368-2005/EN 590: 2004, in India IS 1460/Bharat IV or in an emergency IS 1460/Bharat III).

The diesel fuel may contain **maximum** 7% biodiesel (**B7** - In Germany in accordance with DIN 52638, in Austria ÖNORM C 1590, in France EN 590).

Operating under different weather conditions

Use only diesel in accordance with the current or expected weather conditions. Ask the petrol station personnel whether the diesel fuel offered corresponds to these conditions.

CAUTION

The following instructions must be observed, otherwise there is a risk of engine damage and damage to the exhaust system.

- If a different fuel other than diesel fuel, which complies to the above mentioned standards (e.g. petrol) is put into the tank, do not start the engine or switch on the ignition!
- The biofuel **RME** must not be used!

CAUTION

Diesel fuel additives

- The diesel fuel in accordance with the prescribed standards meets all the conditions for a smooth running engine. Therefore, we recommend that you do not add any fuel additives to the diesel - - there is a risk of engine damage or damage to the exhaust system.

AdBlue® and its refilling

Introduction

In order to reduce pollutant emissions from vehicles with diesel engines and the SCR catalyst, a urea - AdBlue® solution is injected into the exhaust system.

Only use AdBlue® that corresponds to the **standard** ISO 22241-1. Do not add additives to AdBlue®.

The AdBlue®-**consumption** depends on driving style, the operating temperature of the system and on the weather conditions.

The AdBlue®-**tank filling** is about **13 litres**.

WARNING

AdBlue® can cause skin, eye and respiratory irritation. If your eyes or skin come into contact with the AdBlue® fluid, immediately wash the affected area with water. Seek medical assistance if required.

! CAUTION

AdBlue® attacks the surface of some materials (e.g. as painted parts, plastics, fabrics). Clean the areas affected with AdBlue® using a damp cloth and plenty of cold water. Remove any dried AdBlue® with warm water and a sponge.

i Note

- The AdBlue® solution freezes at a temperature of -11° C and lower. The system has an automatic heater to ensure the operability at low temperatures.
- We recommend purchasing AdBlue® refill bottles from the ŠKODA original parts.
- The working life of the AdBlue® solution is 4 years. If the tank contents are not used within this period, then this is to be replaced by a specialist garage. When topping up, do not use AdBlue® for which the shelf life has expired.
- AdBlue® is a registered trademark of the VDA. AdBlue® is also known as AUS 32 (Aqueous Urea Solution) or DEF (Diesel Exhaust Fluid).

Check level

📖 Read and observe **!** and **!** on page 267 first.

The AdBlue® level is automatically monitored.

The driving distance that can be driven with the existing AdBlue® Tank capacity as well as indication of the minimum and maximum AdBlue® - Refill quantity, can be displayed using the driving data » [page 51](#).

If the available travel distance that can be completed with the remaining AdBlue® tank capacity drops to about 2400 km, the warning  appears on the instrument cluster and a request for replenishment of AdBlue® appears.

If the available travel distance that can be driven with the existing AdBlue® - tank capacity drops down to 0 km, **then no motor start is possible**. In this case, if possible, top up AdBlue® to the maximum fill level.

AdBlue® Refill

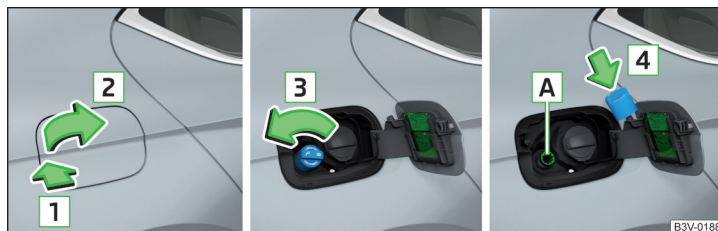



Fig. 316 **Open fuel filler flap / unscrew tank cap / place the tank cap on the fuel filler flap**

📖 Read and observe **!** and **!** on page 267 first.

AdBlue® You can even top up using a fuel nozzle at a petrol station or a refill bottle, if necessary at a specialist garage.

We recommend when refilling using refill bottles that you use refill bottles from ŠKODA Original Accessories.

When adding AdBlue® take note of the minimum and maximum AdBlue® tank capacity shown in the display of the instrument cluster together with warning light .

Refill AdBlue® under the following conditions.

- ✓ The vehicle is on a horizontal surface.
- ✓ The ignition is switched off.

Refilling

- Press the fuel filler flap in the direction of arrow **1** and open it in the direction of arrow **2** » [Fig. 316](#).
- Unscrew the tank cap in the direction of arrow **3**.
- Remove the tank cap and place in the recess on top of the fuel filler flap in the direction of arrow **4**.
- Refill AdBlue® in the neck **A** by means of a refill or a fuel nozzle refill (follow the instructions on the container or the instructions of the petrol station operator).

The AdBlue® - tank is full when no AdBlue® flows from the refill bottle or as soon as the correctly operated pump cuts out for the first time. Do not continue refilling AdBlue®.

- After refilling AdBlue® put the cap on the fuel filler neck and turn in the opposite direction of the arrow **3** until it engages.
- Close the fuel filler flap until it clicks into place.

Before continuing your journey, switch on just the ignition for 30 s so that the refilling can be recognized by the system. Only then start the engine.

! CAUTION

When refilling AdBlue® Do not exceed the maximum refill quantity specified in the instrument cluster - there is a risk of damage to the AdBlue® systems.

Engine compartment

Introduction

! WARNING

Never cover the engine with additional insulation material (e.g. with a cover) – risk of fire!

! WARNING

When working in the engine compartment, the following instructions must be observed - risk of injury or fire. The engine compartment of your car is a hazardous area!

! WARNING

Instructions before beginning work in the engine compartment

- Stop the engine and remove the ignition key, on vehicles with the KESSY system, open the driver's door.
- Switch on the parking brake.
- For vehicles with **manual transmission** the lever into the neutral position. On vehicles with **automatic transmission**, place the selector lever in the **P** position.
- Allow the engine to cool.
- Never open the bonnet if you can see steam or coolant flowing out of the engine compartment – risk of scalding! Wait until the steam or coolant has stopped escaping.

! WARNING

Information for working in the engine room

- Keep everyone away from the engine compartment.
- Do not touch any hot engine parts – risk of burns!
- Never touch the radiator fan. The radiator fan suddenly switch on approx. 10 minutes after switching off the ignition!
- Do not smoke or use open flames in the vicinity of the engine.
- Do not leave any items (e.g. cloths or tools) in the engine compartment. This presents a fire hazard and the risk of engine damage.
- Read and observe the information and warning instructions on the fluid containers.

! WARNING

Information for working in the engine compartment with the engine running

- If it is necessary to work on the engine compartment with the engine running, then observe the **rotating engine parts and electrical plants** - it can be fatal!
- Never touch the electric wiring on the ignition system.
- Avoid short circuits in the electrical system, particularly on the vehicle's battery.

! CAUTION

Refill only operating fluids of the correct specification - danger of damaging the vehicle!

i Note

- Fluids with the proper specifications can be purchased from the ŠKODA Original Accessories or from the ŠKODA Genuine Parts ranges.
- We recommend you have the battery replaced by a specialist garage.

Open the bonnet and close



Fig. 317 Opening the bonnet

Read and observe **!** and **!** on page 269 first.

Open flap

- › Make sure that the windscreen wiper arms are not folded away from the windscreen - there is a risk of damage to the bonnet.
- › Open the driver's door and pull the unlocking lever below the dashboard in the direction of arrow **1** » Fig. 317.
- › Press the release lever in the direction of the arrow **2** and the bonnet is unlocked.
- › Hold the bonnet and lift up until it is held open by the pressurised gas spring.

Close the bonnet lid

- › Pull the bonnet lid down far enough to overcome the force of the pressurised gas spring.
- › From around 20 cm, lightly push the bonnet lid closed until it securely engages.

If the bonnet lid is not properly closed, the display of the instrument cluster will show this.

! WARNING

- Never drive if the bonnet is open - could cause an accident!
- Make sure that when closing the engine compartment lid, no body parts are crushed - there is danger of injury!

! CAUTION

When closing the bonnet "do not press down" - there is a risk of damaging the bonnet.

Engine compartment overview

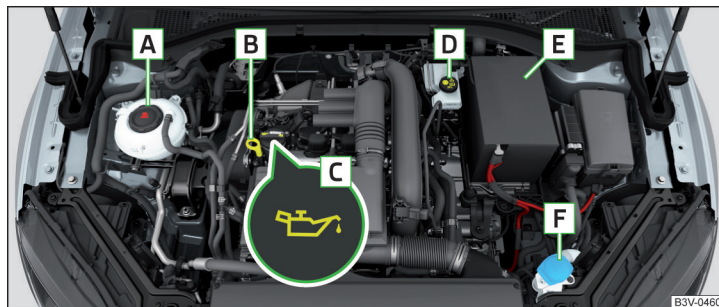

Fig. 318 Arrangement example in the engine compartment

Read and observe **!** and **!** on page 269 first.

A	Coolant expansion tank	_____	272
B	Engine oil dipstick	_____	271
C	Engine oil filler opening	_____	271
D	Brake fluid reservoir	_____	273
E	Vehicle battery	_____	274
F	Windscreen washer fluid reservoir	_____	271

Windscreen washer fluid



Fig. 319 Windscreen washer fluid reservoir

📖 Read and observe **!** and **!** on page 269 first.

The installation location of the container support can differ depending on the type of engine » Fig. 319.

The capacity of the reservoir **A** is about 3.1 litres or about 4.7 litres on vehicles that have a headlight cleaning system. The contents of the container **B** are approximately 3.7 litres.

Use a suitable windscreen washer fluid in accordance with the current or expected weather conditions. We recommend that you use accessories from ŠKODA Original Accessories.

! CAUTION

- Only use liquids that do not attack polycarbonates - otherwise there is a risk of damage to the headlights.
- Do not remove the filter from the windscreen washer fluid reservoir when replenishing it with liquid otherwise the liquid transportation system can become contaminated, which can cause the windscreen washer system to malfunction.

Engine oil

Specification

To find out which type of engine oil you can use for your vehicle, contact a specialist garage.

If this oil is not available, other oils can also be refilled. To prevent engine damage, a **maximum of 0.5 l** of engine oil with the following specifications may be used until the next oil change:

- ▶ Petrol engines: VW 504 00, VW 502 00, VW 508 00, ACEA A3/ACEA B4 or API SN, (API SM);
- ▶ Diesel engines: VW 507 00, ACEA C3 or API CJ-4.

Engine oil VW 505 01 can optionally be used in diesel engines without a **diesel particulate filter**.

Check and refill

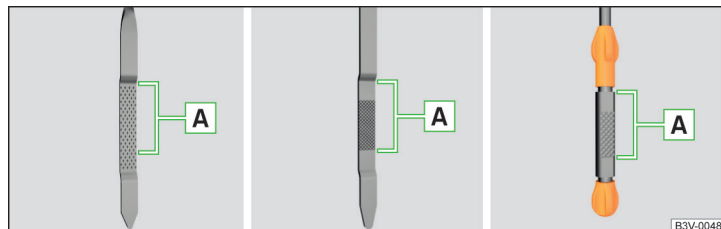

Fig. 320 Dipstick variants

Depending on the driving style and operating conditions, the engine uses some oil (up to 0.5 l / 1 000 km). Consumption may be slightly higher than this during the first 5 000 km.

Have the **oil change** carried out by a specialist garage during the inspection.

Check the oil under the following conditions and refill.

- ✓ The vehicle is standing on a horizontal surface.
- ✓ The engine operating temperature is reached.
- ✓ The engine is turned off.

Checking the level

- ▶ Wait a few minutes until the engine oil flows back into the oil trough.
- ▶ Remove the dipstick and wipe with a clean cloth.
- ▶ Push the dipstick to the stop and pull out again.
- ▶ Read the oil level and push in the dipstick.

The oil level must be in range **A** » Fig. 320. If the oil level is below the range **A**, refill the oil.

Refilling

- › Unscrew the cap of the engine oil filler opening **C** » Fig. 318 on page 270.
- › Add oil of the correct specification in increments of 0.5 litres » page 271.
- › Check the oil level .
- › Screw the lid of the engine oil filler closed carefully.

! WARNING

The following warning instructions must be followed at all times when working in the engine compartment » page 269.

! CAUTION

- The oil level must never fall outside range **A** » Fig. 320 - otherwise there is a risk of damaging the engine and the exhaust system.
- If a top up with oil is not possible or the oil level is above range **A**,  stop driving! Switch off the engine and seek assistance from a specialist garage.
- Do not add additives to the engine oil - risk of engine damage.

i Note

- Too low engine oil level is shown in the instrument cluster by the  warning light illuminating and also indicated by the message » page 45. Nevertheless, we recommend to check the oil level on a regular basis with the dipstick.
- We recommend that you use oils from ŠKODA Original Accessories.

Coolant

Introduction

The coolant cools the engine and consists of water and coolant additive (with additives that protect the cooling system against corrosion and prevents furring).

The coolant additive proportion in the coolant must be between 40 and 60 %.

The correct mixing ratio of water and coolant additive should be checked if necessary by a specialist garage or corrected if necessary.

! WARNING

- The following warning instructions must be followed at all times when working in the engine compartment » page 269.
- Never open the end cover of the coolant expansion reservoir while the engine is still warm. The cooling system is pressurized - risk of scalding or injury from being splashed with coolant!
- To protect against coolant splashes, cover the cap with a cloth when opening.
- Coolant and coolant fumes are harmful - avoid contact with the coolant. If your eyes or skin come into contact with the coolant, immediately wash the affected area for a few minutes long with a lot of water and seek medical advice if required.

! CAUTION

Do not cover the radiator or fit any parts (e.g. auxiliary lights) in front of the air intakes - there is a risk of the engine overheating.

Checking and refilling

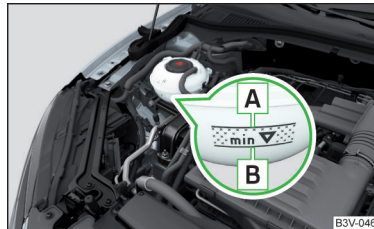

Fig. 321
Coolant expansion reservoir

 **Read and observe ! and ! on page 272 first.**

Check the coolant under the following conditions and refill.

- ✓ The vehicle is on a horizontal surface.
- ✓ The engine is not warm (if the engine is warm, the test results could be inaccurate).
- ✓ The engine is turned off.

Check the coolant level - the coolant level must be between the marks **A** and **B** » Fig. 321. If the coolant level is below the mark **B**, refill the coolant. ▶

Refilling

The coolant expansion tank must always contain a small amount of coolant

» **I**.

- › Place a cloth over the cap of the coolant expansion tank and unscrew the cap **carefully**.
- › Always top up using the correct specification of fluids.
- › Turn the cap until it clicks into place.

The **specification** of the coolant is shown on the coolant expansion reservoir » Fig. 321.

If no specified coolant is available, use only distilled or demineralised water and have the mixing ratio of water and coolant additive corrected by a specialist garage as soon as possible.

I CAUTION

- If the expansion tank is empty, do not top up with coolant. The system could aerate - risk of damaging the engine! **!** Do not drive the vehicle! Switch off the engine and seek assistance from a specialist garage.
- Do not fill the coolant above the mark **A** » Fig. 321. When it heats up, the coolant could press out of the cooling system - there is a risk of damage to the engine parts.
- If it is not possible to add coolant, **!** stop driving! Switch off the engine and seek assistance from a specialist garage.
- A coolant additive which does not correspond to the correct specification can reduce the anti-corrosion effect of the cooling system - there is a risk of damage to the cooling system and the engine.
- If water other than distilled (demineralised) water is used, then have the coolant replaced by a specialist garage - there is a risk of engine damage.
- A loss of coolant could be due to **leaks** in the cooling system - there is a risk of engine damage. Switch off the engine and seek assistance from a specialist garage.

I Note

A coolant level which is too low is indicated in the instrument cluster by the warning light **!** and shown by the relevant message » page 45. We still recommend inspecting the coolant level directly at the reservoir from time to time.

Brake fluid



Fig. 322
Brake fluid reservoir

Check the brake fluid under the following conditions.

- ✓ The vehicle is on a horizontal surface.
- ✓ The engine is turned off.

Check brake fluid level - the brake fluid level must be between the markings "MIN" and "MAX" » Fig. 322.

Specification - the brake fluid must comply with **VW 501 14** standard (this standard meets the requirements of FMVSS 116 DOT4).

The **brake fluid change** is carried out during the inspection.

! WARNING

- If the date of the brake fluid change is exceeded, steam bubbles could form in the brake system during heavy braking. This can impair the efficiency of the brakes - risk of accident!
- The following warning instructions must be followed at all times when working in the engine compartment » page 269.
- There may be an indication of a leak in the brake system, however, if the fluid level drops significantly within a short time or if it drops below the "MIN" » Fig. 322 marking. **!** Do not continue driving - There is a risk of accident! Seek help from a specialist garage.

I Note

A low brake fluid level which is too low is indicated by the warning light **!** being shown on the display of the instrument cluster as well as the corresponding message » page 40. We therefore recommend that you check the coolant level directly at the reservoir from time to time.

Vehicle battery

Introduction





The vehicle battery represents a power source for the motor to start and for the supply of electrical consumers in the car.

Automatic consumer shutdown - discharge protection of the vehicle battery

The on-board power supply tries as follows to avoid draining the vehicle battery when it is heavily loaded.

- ▶ By increasing the engine idle speed.
- ▶ By limiting the power of certain consumers.
- ▶ By turning off some consumers (heated seats, heated rear window) for as long as necessary.

Warning symbols on the vehicle battery

Symbol	Meaning
	Always wear eye protection.
	Battery acid is severely caustic. Always wear gloves and eye protection.
	Keep fire, sparks, open flames and lit cigarettes well clear of the vehicle battery.
	When charging the vehicle battery, a highly explosive gas mixture is produced.
	Keep children away from the vehicle battery.

! WARNING

Battery acid is highly corrosive - risk of injury, irritation or poisoning! Corrosive vapours in the air irritate and damage the respiratory tract and the eyes. The following guidelines must be observed.

- Always wear protective gloves, eye and skin protection when handling the vehicle battery.
- If your eyes or skin come into contact with the electrolyte fluid, immediately wash the affected area for a few minutes with plenty of water. Seek medical assistance if required.

! WARNING (Continued)

- Keep the vehicle battery away from people who are not completely independent, especially children.
- Do not tilt the battery otherwise battery electrolyte may flow out of the battery vent openings.

! WARNING

When working on the car battery, there is the risk of explosion, fire, injury or irritation! The following guidelines must be observed.

- Avoid smoking, the use of open flames or light and any activities that could cause sparks.
- **A discharged vehicle battery can freeze slightly.** Never charge up a frozen or thawed vehicle battery. Replace a frozen vehicle battery.
- Never use a damaged vehicle battery – risk of explosion!
- Do not connect the battery terminals with each other by bridging the two poles of a short circuit.

! CAUTION

Ensure that battery acid does not come into contact with the bodywork – risk of damage to the paintwork.

i Note

- We recommend having all work on the vehicle battery carried out by a specialist garage.
- You should replace batteries older than 5 years.

Check condition

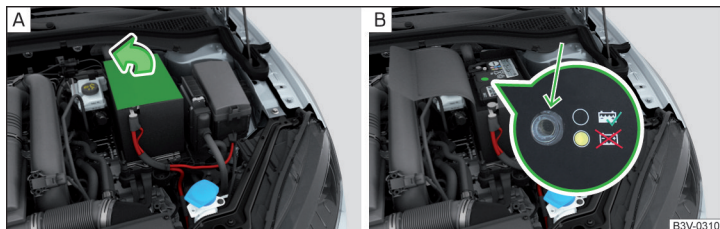

Fig. 323 Vehicle battery: Open the cover / acid level indicator

Read and observe **!** and **!** on page 274 first.

The battery condition is checked regularly by a specialist garage as part of the inspection service.

Check the acid level

For car batteries with acid level indicator, use the colouration of the display to check the acid level. In vehicle batteries with the designation “AGM” there is no acid level examination.

Depending on the equipment, the vehicle battery may be provided with a cover, this can be opened in the direction of arrow » Fig. 323 - [A].

Air bubbles can influence the colour of the indicator. Therefore, carefully knock on the display » Fig. 323 - [B].

Black colour - electrolyte level is correct.

Colourless or light yellow colour - electrolyte level too low, the battery must be replaced.

Battery discharge

Frequent short journeys will not sufficiently recharge the car battery.

The battery capacity decreases at low temperatures.

If the vehicle is not used for longer than 3 to 4 weeks, then disconnect the negative terminal \ominus or charge the battery constantly with a very low charging current.

Charging

Read and observe **!** and **!** on page 274 first.

Only charge the vehicle battery when the ignition and all consumers are switched off.

Refer to the instructions of the charger manufacturer.

Charging

- For vehicles **with** START-STOP system or auxiliary heating, connect the \oplus terminal of the charger on the \oplus pole of the battery, the \ominus terminal of the charger to the earth point of the engine » page 288.
- For vehicles **without** START-STOP system or auxiliary heating, connect the terminals of the charger to the corresponding battery poles (\oplus at \oplus , \ominus at \ominus).
- Plug the mains cable of the charger into the power socket and switch on the device.
- After charging has been successful: Switch off the charger and remove the mains cable from the power socket.
- Disconnect the terminals of the charger from the vehicle battery.

A charging current of 0.1 multiple of the total vehicle battery capacity (or lower) must be used until full charging is achieved.

! WARNING

- When charging the vehicle battery, hydrogen is released - risk of explosion. An explosion can be caused from sparks or connection or releasing the cable plug while the ignition is on.
- The so-called “quick charging” of the vehicle battery is **dangerous** and requires a special charger and specialist knowledge. Therefore, have “Quick loading” carried out by a specialist garage.

Disconnect/reconnect and change

Read and observe **!** and **!** on page 274 first.

We recommend you have the battery **replaced** by a specialist garage.

The new vehicle battery must have the same capacity, voltage, current and the same size as the original Battery. ▶

Connecting/disconnecting

- ▶ To **disconnect** the battery, switch off the ignition and disconnect first the negative terminal ⊖, and only after this the positive ⊕.
- ▶ To **connect** the battery, first connect the positive terminal ⊕, and only after this the negative terminal ⊖.

After disconnecting and re-connecting the vehicle battery, the following functions or devices are partially or completely inoperative.

Function / device	Operating measure
Power windows	» page 68
Panorama sliding/tilting roof	» page 69
Sun screen	» page 70
Time setting	» page 49

! CAUTION

- Disconnect the vehicle battery only with the ignition turned off - there is a risk of damaging the electrical system of the vehicle.
- Before disconnecting the battery, close the electric tailgate, all the windows, the sliding / tilting roof and the electric sunshade - otherwise malfunctions of equipment elements may occur.
- Under no circumstances must the connection cables be connected incorrectly - risk of fire.

i Note

After disconnecting and re-connecting the vehicle battery, we recommend having the vehicle checked by a specialist to ensure that the full functionality of all electrical systems is guaranteed.

Wheels

Wheels and tyres

Advice on tyre/wheel usage

New tyres, during the first 500 km, new tyres do not offer optimum grip and appropriate care should therefore be taken when driving.

Always fit **tyres with a greater profile depth** on the front wheels.

Wheels and bolts are matched to each other in terms of design. We recommend that you use wheel rims and wheel bolts from ŠKODA Original Accessories.

Always **store wheels or tyres** in a cool, dry and, where possible, dark place. The tyres themselves should be stored standing.

Tyre life

Tyres age and lose their original characteristics, even if they are not being used. Do not use tyres that are older than 6 years.

The manufacturing date is indicated on the tyre sidewall (possibly on the **inside**). E.g. **DOT ... 10 18...** means that the tyres were produced in the 10th week of the year 2018.

Tyre damage

We recommend checking your tyres and wheel rims for damage (punctures, cuts, splits and bulges, etc.) on a regular basis.

Remove any foreign objects in the tyre tread immediately (e.g. small stones).

Foreign bodies which **have penetrated into the tyre** (e.g. screws or nails) should not be removed. Seek help from a specialist garage.

Installation of new tyres

Only fit radial tyres of the same type, size (rolling circumference) and the same tread pattern on one axle on all 4 wheels.

When mounting new tyres the tyres have to be replaced axle by axle.

Uni-directional tires

Some tires may be directional. The direction of rotation of the tyres is marked by **arrows on the wall of the tyre**. ▶

The specified running direction must be strictly adhered to, otherwise the following tyre characteristics may be degraded.

- ▶ Driving stability.
- ▶ Traction.
- ▶ Tyre noise and tyre wear.

Tyres with increased resistance to air loss when punctured

Some vehicles may be fitted with tyres at the factory that have increased puncture resistance (so-called "SEAL" tyres). For some countries, vehicles are equipped with "SEAL" tyres delivered without a spare wheel and appropriate tools.

If "SEAL" tyres are replaced with standard tyres, the vehicle must be retrofitted with a puncture repair kit or spare wheel and appropriate hand tools.

! WARNING

Never use damaged tyres or tyres that are older than 6 years old – risk of accident.

! CAUTION

- The tyres must be protected from contact with substances such as oil, grease and fuel, which could damage them. If the tyres come into contact with these substances, then we recommend you have this checked out in a specialist workshop.
- Do not use alloy rims with a burnished or polished surface in winter conditions - there is a risk of wheel damage (e.g. from the road grit).

Tyre pressure

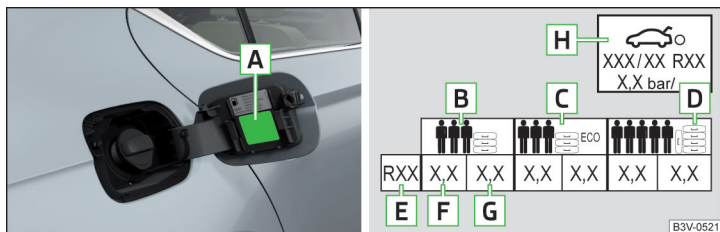

Fig. 324 Label with a table of tyre sizes and tyre pressure value / inflate tyres

The prescribed tyre inflation is on the sticker with pictograms **A** ▶ Fig. 324 (for some countries, the pictograms are replaced with a text).

Tyre pressure is always to match the load.

- B** Inflation pressure for half load
- C** Inflation pressure for environmentally friendly operation (slightly lower fuel consumption and emissions)
- D** Inflation pressure for full load
- E** Tyre diameter in inches

This information serves merely as information for the prescribed tyre pressure. This is not a list of shared tyre sizes for your vehicle. These are in the vehicle's technical documentation, as well as the declaration of conformity (in the so-called COC document).

- F** Tyre pressure value on the front axle
- G** Tyre pressure value on the rear axle
- H** Required tire pressure value for the emergency wheel

Check tyre pressures

Check the tyre pressure, including that of the spare wheel, at least once a month and also before setting off on a long journey.

Always check the inflation pressure when the tyres are cold. Do not reduce the higher pressure of warm tyres.

In vehicles with tyre pressure monitoring, tyre pressure values must be saved each time the pressures are changed » [page 252](#).

! WARNING

- Do not drive with an incorrect tyre pressure - risk of accident.
- In the event of very fast pressure loss, e.g. in the event of sudden tyre damage, an attempt should be made to bring the vehicle carefully to a stop without sudden steering movements and without any hard braking.

i Note

The declaration of conformity (the so-called. COC document) can be obtained from a ŠKODA Partner (only valid for some countries and some models).

Tire wear and wheel change

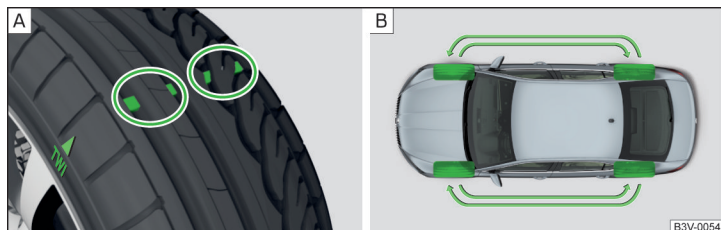

Fig. 325 Tire wear indicator / wheel change

The **tyre wear** increases in the following circumstances.

- ▶ Incorrect tyre pressure.
- ▶ Driving style (e.g. fast cornering, rapid acceleration / deceleration).
- ▶ Incorrect balancing of wheels (have the wheels balanced after changing tyres / repair or with “restlessness” on the steering).
- ▶ Wheel alignment error.

Wear indicators are located in the profile of the tyres which display the permissible minimum tread depth » Fig. 325 - [A]. A tyre is to be regarded as worn out when this indicator is flush with the tread. Markings on the walls of the tyres with the letters “TWI” or other symbols (e.g. Δ) indicate the position of the wear indicators.

The tread depth can be measured with a tread depth gauge on the ice scraper, which is located on the inside of the fuel filler flap.

For uniform wear on all tyres, we recommend that you **change the wheels** every 10,000 km according to the schedule » Fig. 325 - [B].

! WARNING

- Change when they are worn down to the wear indicators at the latest - risk of accident.
- Improper wheel alignment affects the driving behaviour - there is an accident.
- Unusual vibrations or “pulling” of the vehicle to one side could be a sign of tyre damage. Reduce speed and stop! If no tyre damage is evident, seek the assistance of a specialist garage.

Spare wheel

A **full spare wheel** corresponds to the wheel mounted on the vehicle in terms of the wheel dimensions, the tire dimension and the tire type.

A **temporary spare wheel** is provided with a warning label on the rim. Only use this temporary spare wheel to reach the nearest specialist garage since it is not intended for permanent use.

Instructions for using a temporary spare wheel

- ▶ Do not cover the signs.
- ▶ Be particularly observant when driving.

Inflate the spare wheel to the maximum prescribed inflation pressure

» page 277.

! WARNING

A temporary spare wheel can only be used for a short time in the event of a breakdown and with a correspondingly careful driving method.

Spare wheel

A warning label is displayed on the rim of the temporary spare wheel. Only use this temporary spare wheel to reach the nearest specialist garage since it is not intended for permanent use.

The emergency wheel is significantly narrower than the wheels mounted ex-factory.

Instructions for using an emergency wheel

- ▶ Do not cover the signs.
- ▶ Be particularly observant when driving.

! WARNING

- Observe instructions on the warning sign of the emergency wheel.
- Do not drive with more than one spare wheel mounted!
- When driving with the temporary spare wheel at full throttle acceleration, avoid sharp braking and fast cornering.
- Do not use snow chains on the temporary spare wheel.

Tyre marking

Explanation of tyre markings - e.g. 215/60 R 16 95 V

215	Tyre width in mm
60	Height/width ratio in %
R	Code letter for the type of tyre - Radial
16	Diameter of wheel in inches
95	load index
V	Speed symbol

Load index - indicates the maximum permissible load for each individual tyre

load index	91	92	93	94	95	96	97	98	99
Load (in kg)	615	630	650	670	690	710	730	750	775

Speed symbol - indicates the maximum permissible speed for a vehicle fitted with tyres in the category concerned

speed symbol	M	T	U	H	V	W	Y
Maximum speed (in km/h)	130	190	200	210	240	270	300

! WARNING

Never exceed the maximum permissible **load bearing capacity** and **speed** for the tyres fitted - There is a risk of accident.

Operating in winter conditions

All-year (or "winter") tyres

All-season or "winter" tyres (indicated by an **M+S** or a mountain peak/snowflake symbol ) to improve the performance of the vehicle in winter conditions.

For the best possible handling, use all-season or "winter" tyres on all four wheels with a minimum tread depth of 4 mm.

If using "winter" tyres, fit the summer tyres on again in good time as they provide better handling properties, a shorter braking distance, less tyre noise, and reduced tyre wear on roads which are free of snow and ice as well as at temperatures above 7 °C.

Speed symbol

All-season or "winter" tyres (marked with **M+S** and a peak/snowflake symbol ) of a lower speed category than stated in the technical vehicle documentation can be used, provided the permissible maximum speed of these tyres is not exceeded even if the possible maximum speed of the vehicle is higher.

The speed limit for all-season or "winter" tyres can be set in the infotainment system in menu  /  →  → Tyres.

If the vehicle has all-season or "winter" tyres of a lower speed category than the specified maximum speed of the vehicle (referring to tyres that have not been delivered by the factory, a warning label with the maximum value of the speed category provided for the mounted tyres must be fixed in the interior of the vehicle in a constantly visible place in the driver's field of vision. The warning label (sticker) can be replaced by setting the maximum value of the speed category specified for the mounted tyres in Infotainment (only applies to certain countries). This specification defines the maximum vehicle speed with mounted all-season or "winter" tyres that may not be exceeded.

Snow chains

The snow chains improve driving in wintry road conditions.

Before fitting the snow chains, remove the full wheel trims.

Snow chains must only be mounted on the front wheels and are applicable only for the following wheel / tyre combinations.

Applies to 2.0 I / 162 kW TSI and 206 kW TSI

Rim size	Impression depth D	Tyre size
6.5J x 17	41 mm	215/55 R17

Applies to the other engines

Rim size	Impression depth D	Tyre size
6.5J x 16	41 mm	215/60 R16
6.5J x 17	41 mm	215/55 R17

Only fit snow chains with links and locks no larger than 12 mm.

WARNING

Do not use chains on snow- and ice-free routes - the driving behaviour may be affected and there is a risk of a puncture.

Do-it-yourself

Emergency equipment and self-help

Emergency equipment

Placement of the first aid kit and warning triangle

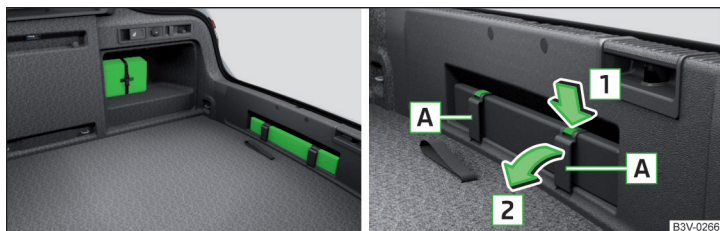

Fig. 326 Placing of the first-aid kit and the warning triangle: Variant 1/detach warning triangle



Fig. 327
Placing of the first-aid kit and
the warning triangle: Variant 2

The following information applies for the first aid kit and warning triangle from the ŠKODA Original Accessories.

Placing the first-aid kit

The first-aid kit can be attached by a strap to the right-hand side of the boot » Fig. 326 or » Fig. 327.

Depending on the equipment fitted, in the same place a storage compartment may be located in which the first aid kit can be stowed.

Placing of the warning triangle - variant 1

The warning triangle can be inserted into the recess under the loading edge and secured with the fastener tape » Fig. 326 .

- › To **release**, press the clasp on the tape in the direction of arrow **1** fold open the belt **A** in the direction of arrow **2** » Fig. 326.
- › To **secure**, fold up the belt **A** against the arrow direction **2** until it locks in-to place.

Placing of the warning triangle - variant 2

The warning triangle can be stored in the recess under the loading edge » Fig. 327. Before it is taken out, the floor covering of the luggage compartment must be raised.

! WARNING

Properly secure the first aid kit and the warning triangle, or there is a risk of injury in the event of sudden braking or a vehicle collision.

Placement of reflective vest

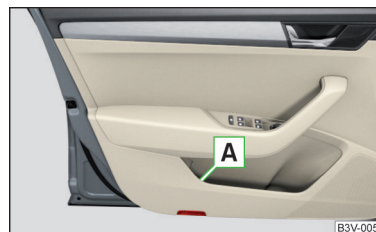

Fig. 328
Stowage compartment for the
reflective vest in the front door

The reflective vest can be stowed in the stowage compartment **A** inside the storage compartment of the front door » Fig. 328.

It is possible to store the reflective vests for the passengers on the rear seat in the storage compartment in the rear doors.

Fire extinguisher

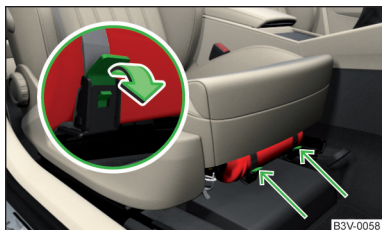

Fig. 329
Release the fire extinguisher

The fire extinguisher is attached by two straps in a bracket under the front passenger's seat.

- To **remove** the fire extinguisher, release the safety catches on the two belts in the direction of arrow » Fig. 329 and remove the fire extinguisher.
- To **secure**, place the fire extinguisher back in the mount and secure with the belts.

The Owner's Manual is fitted next to the fire extinguisher.

Pay attention to the expiration date of the fire extinguisher. After this date, the correct function of the device is not guaranteed.

! WARNING

Always properly secure the fire extinguisher, there is a risk of injury in the event of sudden braking or a vehicle collision.

Vehicle tool kit

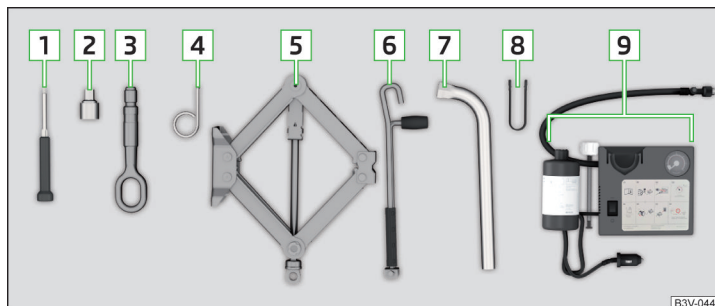

Fig. 330 Vehicle tool kit

The box containing the vehicle tool kit is located in the stowage compartment for the spare wheel, and can be secured with a tape depending on the equipment fitted.

Depending on the vehicle configuration, it may not contain all the components listed in the on-board tool kit.

- 1 Screwdriver
- 2 Adapter for anti-theft wheel bolts
- 3 Towing eye
- 4 Clamps for removing the wheel trims
- 5 Jack with sign
- 6 Crank for the jack
- 7 Wheel wrench
- 8 Extraction pliers for the wheel bolt caps
- 9 Breakdown kit

! WARNING

- The factory-supplied lifting jack is only intended for your model of vehicle. Under no circumstances attempt to lift other vehicles or loads with this – there is a risk of injury.
- Always securely stow the tool in the box and make sure that it is secured to the spare wheel using the tape - there is a risk of injury in the event of sudden braking or a vehicle collision.

! CAUTION

Screw the jack back to its starting position prior to putting it back in its box - Otherwise, there is a risk of damage to the box.

i Note

The declaration of conformity is included with the jack or the log folder.

Changing a wheel

Preliminary work

For safety's sake, the following instructions must be observed before changing a wheel on the road.

- › As far as possible, park the vehicle far away from the traffic flow - find a place with a flat and firm surface.
- › Switch off the engine.
- › For vehicles with **manual transmission**, select 1st gear.
- › For vehicles with **automatic transmission**, place the selector lever in the **P** position.
- › Switch on the parking brake.
- › Position the hazard warning system and the warning triangle at the prescribed distance.
- › **All the occupants should get out of the vehicle.** The passengers should not stand on the road (instead they should remain behind a crash barrier, for instance) while the wheel is being changed.
- › Uncouple any trailers.

Changing a wheel

- › Remove the spare wheel » [page 284](#).
- › Remove the full wheel trim » [page 284](#) or caps » [page 284](#).
- › Loosen the wheel bolts » [page 285](#) » **!**.

- › Jack up the vehicle » [page 285](#) until the wheel that needs changing is clear of the ground.
- › Unscrew the wheel bolts and place them on a clean surface (cloth, paper, etc.).
- › Remove the wheel carefully.
- › Attach the spare wheel and slightly screw on the wheel bolts.
- › Lower the vehicle.
- › Tighten the wheel bolts opposite each other using the wheel wrench (“alternating crosswise”) » [page 285](#).
- › Replace the wheel trim » [page 284](#) and the caps » [page 284](#).

When fitting a wheel with a unidirectional tyre, ensure that the direction of rotation is correct » [page 276](#).

All bolts must be clean and must turn easily. If the screws are corroded and difficult to move, then these must be replaced.

! WARNING

- Undo the wheel bolts just a little (about one turn) while the vehicle is not jacked up. Otherwise, the wheel could come off and fall down – there is a risk of injury.
- Under no circumstances grease or oil the wheel bolts - risk of accident!

Subsequent steps

After changing the wheel, the following work must be carried out.

- › Stow the replaced wheel in the well under the floor covering of the luggage compartment and secure with a locking screw.
- › Stow the tool kit in the space provided and secure using the band.
- › Check and, if necessary, adjust the tyre pressure on the assembled wheel, and, for vehicle with tyre pressure monitoring, save the tyre pressure values in the system » [page 252](#).
- › Have the tightening torque of the wheel bolts checked with a torque wrench as soon as possible. The prescribed tightening torque is **140 Nm**.

Replace the damaged tyre. It is not recommended to repair the tyre. ▶

! WARNING

A tightening torque which is too high can damage the bolts and threads and this can result in permanent deformation of the contact surfaces on the rim. Too low tightening torque, the wheels may fall off while driving - risk of an accident. Therefore, drive cautiously and only at a moderate speed until the tightening torque has been checked.

Removing /stowing the spare wheel



Fig. 331
Take out wheel

The spare wheel is located in a well under the floor covering in the luggage compartment and is fixed in place with a fastening screw » Fig. 331.

Take out wheel

- › Lift up the floor in the luggage compartment.
- › Loosen the retaining belt and take out the box with the tool kit.
- › Unscrew the locking screw in the direction of arrow » Fig. 331 and the remove the wheel.

Store wheel away

- › Place the wheel into the wheel well with the wheel rim pointing downward.
- › Pull the fixing band through the opposite holes in the wheel rim.
- › Screw the locking screw against the direction of arrow until it stops » Fig. 331.
- › Replace the box with the tool kit into the wheel and secure it with the tape.
- › Fold back the floor in the luggage compartment.

Full wheel trim

Removing the trim

- › Hang the clamps for removing the full wheel trims at the edge of one of the ventilation openings in the full wheel trim.

- › Push the wheel wrench through the clamp, support on the tyre and pull off the wheel trim.

Installing the trim

- › Press the wheel trim onto the wheel rim at the designated valve opening.
- › Then press the trim into the wheel rim until its entire circumference locks correctly in place.

The back of the wheel trim supplied by the factory or from the ŠKODA Original Accessories shows the position for the anti-theft wheel bolt. When using the anti-theft wheel bolt, this is to be fitted in this point » **!**

! WARNING

We recommend that you use hub caps from ŠKODA Original Accessories. A sufficient air supply may not be able to be guaranteed with other wheel trims to cool the braking system - Otherwise there is a risk of an accident.

! CAUTION

- If the wheel trim is set outside the position marked for the anti-theft wheel bolt, there is a risk of damaging the wheel trim.
- Use only manual pressure and do not hit the full wheel trim - otherwise there is a risk of damaging the trim.

i Note

We recommend that you use hub caps from ŠKODA Original Accessories.

Wheel bolts



Fig. 332
Remove the cap

- › To **remove the cap**, insert the extraction pliers up to the stop on the cap and pull this in the direction of the arrow » Fig. 332.
- › To **install**, insert the cap up to the stop on the wheel bolt.

Anti-theft wheel bolts

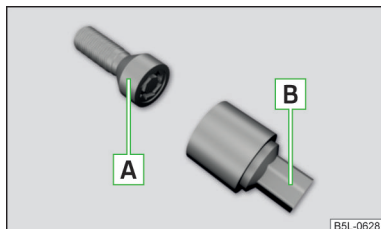

Fig. 333
Anti-theft wheel bolt and upper section

The anti-theft wheel bolts protect the wheels from theft. The upper section **B** » Fig. 333 must be used to **loosen/tighten** these.

- › Insert the upper section **B** on the anti-theft wheel bolt **A** until it stops.
- › Insert the wrench on the attachment **B** until it stops and loose/tighten the wheel bolt.
- › Removing the upper section.

The attachment for the anti-theft wheel bolts must always be kept in the vehicle in case of a possible wheel change!

For wheel trims installed ex-factory or from ŠKODA Original Accessories, the anti-theft wheel bolt should be installed in the position marked on the back of the wheel trim.

i Note

We recommend that you retain the label with the code number. A replacement upper section can be acquired from ŠKODA original parts based on this.

Loosening/tightening wheel bolts



Fig. 334
Loosening the wheel bolts

- › Push the wheel wrench onto the wheel bolt to the stop. Use the associated upper section for the anti-theft wheel bolts » Fig. 333 on page 285.
- › To **loosen the screws**, hold the wrench end and turn the screw about **one** turn in the direction of arrow » Fig. 334.
- › To **tighten the screws**, hold the wrench end and turn the screw against the direction of the arrow » Fig. 334, until it is tight.

! WARNING

If it proves difficult to undo the bolts, carefully apply pressure to the end of the wrench with your **foot**. Keep hold of the vehicle when doing so, and make sure you keep your footing - risk of accident.

Raising the vehicle

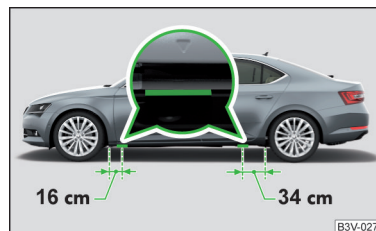

Fig. 335
Jacking points for the jack

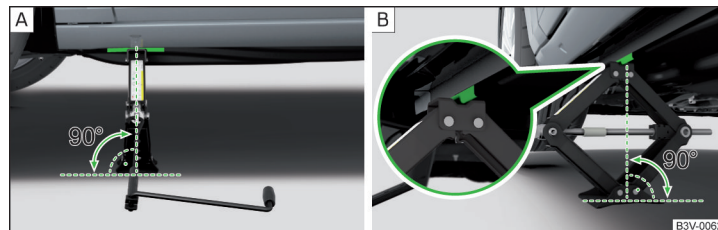

Fig. 336 Attach lifting jack

Before the vehicle is raised, the safety instructions must be observed » **!**

Use the jack from the tool kit to raise the vehicle. Position the jack at the jacking point closest to the wheel to be replaced.

The jacking points are located on the lower sill » Fig. 335.

- › Insert the crank [6] into the mount on the jack [5] » page 282.
- › Support the base plate of the jack with its full area resting on level ground and ensure that the jack is located in a vertical position at the jacking point » Fig. 336 - [A].
- › Use the crank to raise the jack until its claw encloses the bar » Fig. 336 - [B].
- › Continue to lift the vehicle until the wheel is just off the floor.

! WARNING

Observe the following instructions, otherwise there is risk of injury.

- Secure the vehicle from unexpectedly rolling away.
- Always ensure the base plate of the lifting jack cannot slip.
 - Provide a wide and stable base under the jack on loose surfaces (e.g. such as gravel).
 - Create a non-slip base (e.g. a rubber floor mat) under the jack on a smooth surface (e.g. cobblestones).
- Always raise the vehicle with the doors closed.
- Never position any body parts, such as arms or legs, under the vehicle, while the vehicle is raised with a lifting jack.
- When the vehicle is raised, never start the engine.

! CAUTION

It is important to ensure that the jack is correctly attached to the bar of the lower beam – otherwise there is a risk of damage to the vehicle.

Puncture repair kit

Introduction

The following information applies to the factory-fitted puncture repair kit.

Use the puncture repair kit to seal tyre punctures with a diameter of up to about 4 mm.

Performing a repair with the breakdown kit **not at all intended to replace** a permanent repair on the tyre. Its purpose is to get you to the nearest specialist garage.

Immediately replace the tyre that was repaired using the puncture repair kit, or consult a specialist garage about repair options.

Do not remove foreign bodies which have penetrated into the tyre (e.g. nails etc.).

Do **not use** the puncture repair kit in the following instances.

- ▶ The rim is damaged.
- ▶ The outdoor temperature is below the minimum temperature indicated in the instruction manual of the tyre filling bottle with sealant.
- ▶ Tyre punctures of more than 4 mm.
- ▶ There is damage to the tyre wall.
- ▶ The expiration date (see inflation bottle) has passed.

! WARNING

- If the sealant comes into contact with skin, wash the affected area immediately.
- Observe the instructions provided in the puncture repair kit manufacturer's instructions for use.

Description of puncture repair kit

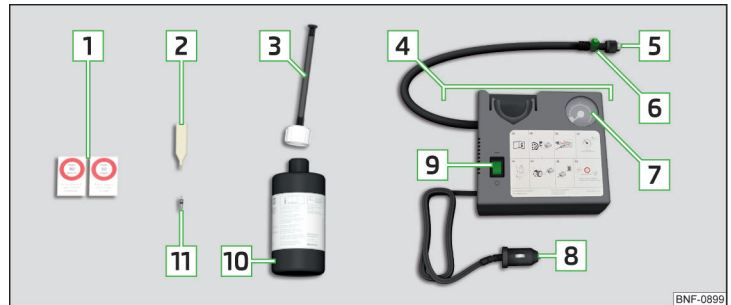

Fig. 337 Description of puncture repair kit

Read and observe ! on page 286 first.

The kit is located in a box under the floor covering in the luggage compartment.

- [1] Sticker with speed designation “max. 80 km/h”/“max. 50 mph”
- [2] Valve remover

- 3** Inflation hose with plug
- 4** Air compressor (the layout of the controls may be different depending on the type of air compressor delivered with the vehicle)
- 5** Tyre inflation hose
- 6** Button for the tyre pressure reduction
- 7** Tyre inflation pressure indicator
- 8** 12 volt cable connector
- 9** ON and OFF switch
- 10** Tyre inflation bottle with sealing agent
- 11** Replacement valve core

i Note

The declaration of conformity is included with the air compressor or the log folder.

Preparing to use the puncture repair kit

 **Read and observe **i** on page 286 first.**

For safety's sake, the following instructions must be observed before performing a wheel repair the road.

- › As far as possible, park the vehicle far away from the traffic flow - find a place with a flat and firm surface.
- › Switch off the engine.
- › For vehicles with **manual transmission**, select 1st gear.
- › For vehicles with **automatic transmission**, place the selector lever in the P position.
- › Switch on the parking brake.
- › Position the hazard warning system and the warning triangle at the prescribed distance.
- › **All the occupants should get out of the vehicle.** The passengers should not stand on the road (instead they should remain behind a crash barrier, for instance) while the wheel is being repaired.
- › Uncouple any trailers.

Sealing and inflating tyres

 **Read and observe **i** on page 286 first.**

Sealing

- › Unscrew the valve cap from the damaged tyre.
- › Insert the valve remover **2** » Fig. 337 on page 286 on the valve insert, so that the valve insert fits into the slot of the valve remover.
- › Unscrew the valve insert and lay it on a clean surface (e.g. cloth, paper etc.).
- › Forcefully shake bottle **10** several times.
- › Firmly screw the inflation hose **3** onto the tyre inflater bottle **10**. The film on the cap is pierced automatically.
- › Remove the plug from the inflation hose **3** and plug the open end fully onto the tyre valve.
- › Hold the bottle **10** with the bottom facing upwards and fill all of the sealing agent from the tyre inflater bottle into the tyre.
- › Remove the filler plug from the tyre valve.
- › Screw in the valve insert using the valve remover **2**.

Inflating

- › Screw the air compressor tyre inflation hose **5** » Fig. 337 on page 286 firmly onto the tyre valve.
- › For vehicles with **manual transmission**, set the lever in the neutral position.
- › On vehicles with **automatic transmission**, place the selector lever in the P position.
- › Start the engine.
- › Plug the connector **8** into 12 volt socket » page 100.
- › Switch on the air compressor with the ON and OFF switch **9**.
- › Once a tyre inflation pressure of 2.0-2.5 bar is reached, turn off the air compressor. Observe the maximum running time of the air compressor according to the instructions of the repair kit manufacturer » **i**.
- › If you cannot reach an air pressure of 2.0 - 2.5 bar, unscrew the tyre inflation hose **5** from the tyre valve.
- › Drive the vehicle approx. 10 metres forwards or backwards to allow the sealing agent to "distribute" in the tyre.
- › Firmly screw the tyre inflation hose **5** back onto the tyre valve and repeat the inflation process.
- › Stick the corresponding sticker **1** on the dashboard in the driver's field of view.

Once a tyre inflation pressure of 2.0 – 2.5 bar is achieved, continue the journey at a maximum speed of 80 km/h (50 mph).

! WARNING

- If the tyre does not inflate to at least 2.0 bar, the damage is too great. The sealing agent cannot be used to seal the tyre. 🛑 Do not drive the vehicle! Seek help from a specialist garage.
- The tyre inflation hose and air compressor may get hot as the tyre is being inflated – risk of burning.

! CAUTION

Switch off the air compressor at the latest after the running time according to the instructions of the repair kit manufacturer has elapsed – otherwise there is the risk of compressor damage! Allow the air compressor to cool a few minutes before switching it on again.

Information for driving with repaired tyres

📖 Read and observe ! on page 286 first.

The inflation pressure of the repaired tyre must be checked after driving for 10 minutes.

If the tyre inflation pressure is 1.3 bar or less

➤ The tyre cannot be properly sealed with the breakdown kit. 🛑 Do not drive the vehicle! Seek help from a specialist garage.

If the tyre inflation pressure is 1.3 bar or more

➤ Set the tyre pressure back to the correct value » page 277.

➤ Continue driving carefully to the nearest specialist garage at a maximum speed of 80 km/h (50 mph).

! WARNING

A tyre filled with sealant has the same driving characteristics as a standard tyre. The following guidelines must be observed.

- Do not drive faster than 80 km/h (50 mph).
- Avoid accelerating at full throttle, sharp braking and fast cornering.

Jump-starting

📖 Introduction

! WARNING

- The following instructions must be followed at all times when working on the engine compartment » page 269.
- When handling the vehicle battery, the following warnings must be observed » page 274.
- A discharged vehicle battery may already freeze at temperatures just below 0 °C. If the battery is frozen, do not carry out a jump start with the battery of another vehicle – risk of explosion!
- Never jump-start vehicle batteries with an acid level that is too low – risk of explosion and caustic burns!

Start using the battery from another vehicle

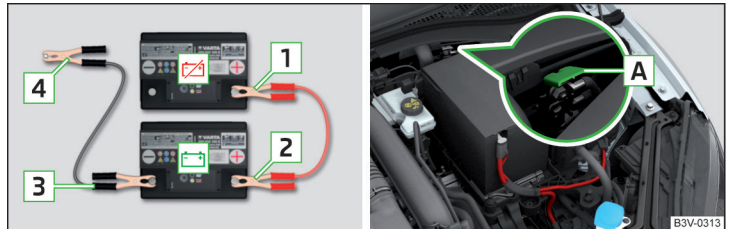

Fig. 338 Jump-starting: 🗑️ - discharged battery, 🔋 - power-supplying battery/ground point of the engine for the START-STOP system

📖 Read and observe ! on page 288 first.

If it is not possible to start the engine due to a discharged vehicle battery, the battery of another vehicle can be used to start the engine. Only use jump-start cables which have an adequately large cross-section and insulated terminal clamps.

The **rated voltage** of the two batteries must be 12V. The **capacity** (Ah) of the current-giving battery must not be significantly less than the capacity of the discharged battery in your vehicle.

The jump-start cables must be attached in the following sequence.

- Attach clamp **1** to the positive terminal of the discharged battery.
- Attach clamp **2** to the positive terminal of the current-giving battery.
- Attach clamp **3** to the negative terminal of the current-giving battery.
- For vehicles **with** the START-STOP system, secure the clamp **4** to the ground point of the engine **A** » Fig. 338.
- For vehicles **without** the START-STOP system, secure the clamp **4** to a solid metal part that is firmly attached to the engine block or secure to the engine block directly.

Starting engine

- Start the engine on the vehicle providing the power and allow it to idle.
- Start the engine in the vehicle with the discharged battery.
- If the engine does not start within 10 s, then cancel the starting procedure and repeat after half a minute.
- Remove the jump start cables in the **reverse** order as attachment.

! WARNING

- Never clamp the jump-start cable to the negative terminal of the discharged battery - danger of explosion.
- The non-insulated parts of the terminal clamps must never touch each other - risk of short circuit!
- The jump-start cable connected to the positive terminal of the battery must not come into contact with electrically conducting parts of the vehicle - risk of short circuit!
- Route the jumper cables so that they cannot be caught in rotating parts in the engine compartment - danger of injuries and the risk of vehicle damage.

Towing the vehicle

Information about the towing process

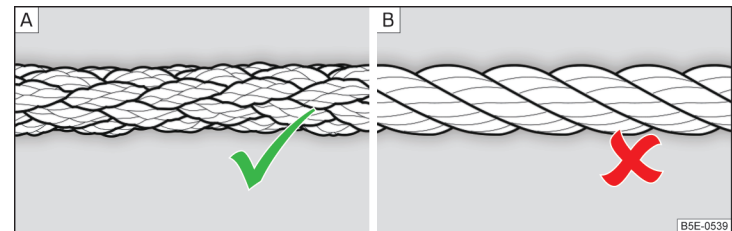

Fig. 339 Braided tow rope / Spiral tow rope

For towing using a tow rope, use only a braided synthetic fibre rope » Fig. 339 - **A** » **!**

Attach the tow rope or the tow bar to the **towing eyes at the front** » page 290, **towing eyes at the rear** » page 290 or to the **towing device of the trailer device** » page 254.

Conditions for towing.

- ✓ **Cars with automatic gearboxes must not be towed with the rear wheels raised - there is a risk of gearbox damage!**
- ✓ If the gearbox has no oil, your vehicle must be towed with the front axle raised clear of the ground or on a breakdown vehicle or trailer.
- ✓ The maximum towing speed is **50 km/h**.
- ✓ The vehicle must be transported on a special breakdown vehicle or trailer if it is not possible to tow in the vehicle in the way described or if the towing distance is greater than 50 km.

Driver of the tow vehicle

- On vehicles with **manual transmission**, engage gear slowly when starting.
- On vehicles with **automatic transmission**, accelerate with particular care.
- Only then approach correctly when the rope is taut. ▶

Driver of the towed vehicle

- › If possible, the vehicle should be towed with the engine running. Operate the brake booster and power steering only if the engine is running, otherwise the brake pedal must be depressed more strongly and more power has to be directed to the steering.
- › If it is not possible to start the engine, switch on the ignition so that the steering wheel is not locked and so that the turn signal lights, windscreen wipers and windscreen washer system can be used.
- › Take the vehicle out of gear or move the selector lever into position **N** if the vehicle is fitted with an automatic gearbox.
- › Always keep the tow rope taut during the towing procedure.

! WARNING

- Wound tow ropes must not be used for towing » Fig. 339- [B], the towing eye may unscrew out of the vehicle - risk of accident.
- Ensure tow rope is not twisted - risk of accident.

! CAUTION

- Do not tow-start the engine – risk of damaging the engine! The battery from another vehicle can be used as a jump-start aid » page 288, *Jump-starting*.
- In the case of off-road towing manoeuvres, for both vehicles there is the risk that the fastening parts could be overloaded and damaged.

i Note

We recommend that you use the tow rope from ŠKODA Original Accessories.

Front towing eye

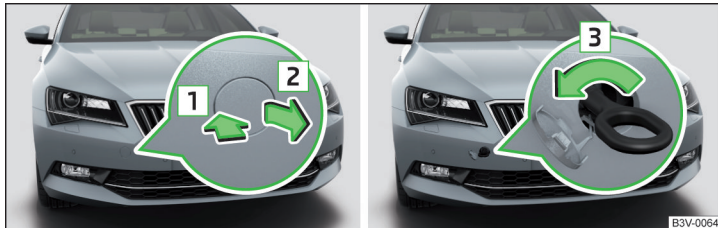

Fig. 340 Remove cap / install towing eye

Remove/insert cap

- › To **remove**, press on the cap in the direction of the arrow **1** and remove this in the direction of arrow **2** » Fig. 340.
- › To **insert**, insert the cap in arrow range **1** and then press on the opposite edge of the cap. The cap must engage firmly.

Removing/installing the towing eye

- › To **install**, screw in the towing eye by hand in the direction of arrow **3** » Fig. 340 until the stop » **!**
- › **Tighten** the towing eye using a wheel wrench or similar object. To do this, insert the wheel wrench through the eye.
- › To **remove**, unscrew the towing against the direction of arrow **3**.

! WARNING

The towing eye must always be tightened, otherwise the towing eye may break during the towing.

Towing eye rear



Fig. 341 Remove cap / install towing eye

Remove/insert cap

- › To **remove**, press on the cap in the direction of the arrow **1** and remove this in the direction of arrow **2** » Fig. 341.
- › To **insert**, insert the cap in arrow range **1** and then press on the opposite edge of the cap. The cap must engage firmly.

Removing/installing the towing eye

- › To **install**, screw in the towing eye by hand in the direction of arrow **3** » Fig. 341 until the stop » **!**

- › **Tighten** the towing eye using a wheel wrench or similar object. To do this, insert the wheel wrench through the eye.
- › To **remove**, unscrew the towing against the direction of arrow **3**.

Vehicles with a tow hitch

For vehicles with factory-fitted towing device, at the back there is no mount for a screw-in towing eye. Use the detachable ball rod for towing » [page 254](#), *Hitch*.

! WARNING

The towing eye must always be tightened, otherwise the towing eye may break during the towing.

Remote control and removable light - changing the battery

Introduction

! CAUTION

- The replacement battery/batteries must comply with the original specification.
- Pay attention to the correct polarity when changing the rechargeable batteries.

i Note

We recommend having the faulty battery/batteries replaced by a specialist garage.

Key with fold-out key bit



Fig. 342 Open the cover/remove the battery

Read and observe **!** on page 291 first.

- › Fold out the key bit.
- › Press off the battery cover **A** » [Fig. 342](#) with your thumb or by using a flat screwdriver in region **B**.
- › Open the battery in the direction of the arrow **1**.
- › Remove the discharged battery in the direction of arrow **2**.
- › Hold any button on the key for about 5 s.
- › Insert the new battery.
- › Insert the battery cover **A** and press it down until it clicks audibly into place.

The key has to be synchronised if the vehicle cannot be unlocked or locked with the key after replacing the battery » [page 62](#).

KESY key

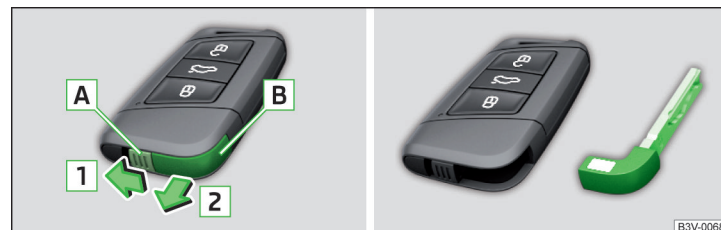

Fig. 343 Remove emergency key

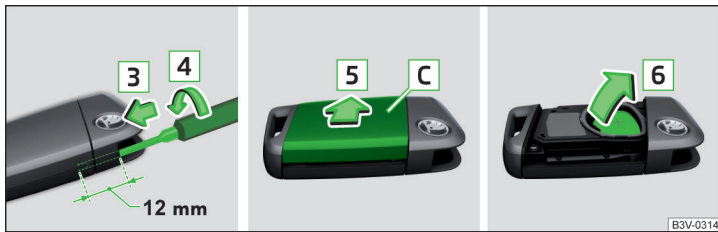

Fig. 344 Open the cover/remove the battery

Read and observe **!** on page 291 first.

- › Unlock the locking lug **A** in the direction of arrow **1** and remove the emergency key **B** in the direction of arrow **2** » Fig. 343.
- › Insert a narrow screwdriver (3 mm wide) approximately 12 mm into the opening in the direction of arrow **3** » Fig. 344.
- › Turn the screwdriver in the direction of arrow **4** until the battery cover is released.
- › Push the battery cover **C** in the direction of arrow **5**.
- › Remove the discharged battery in the direction of arrow **6**.
- › Hold any button on the key for about 5 s.
- › Insert the new battery.
- › Insert the battery cover **C** and press it down until it clicks audibly into place.

The key has to be synchronised if the vehicle cannot be unlocked or locked with the key after replacing the battery » page 62.

Remote control of the auxiliary heating

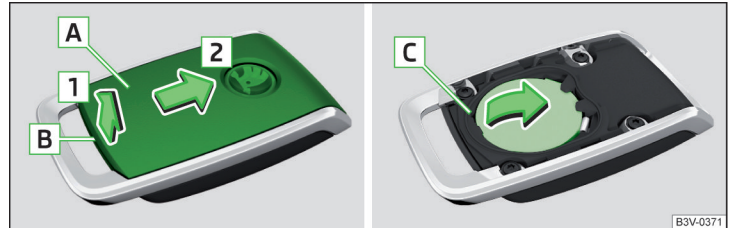

Fig. 345 Open the cover/remove the battery

Read and observe **!** on page 291 first.

- › Use a thin screwdriver to remove the cover **A** in the area **B** » Fig. 345.
- › Open the cover in the direction of arrow **1** and push out in the direction of arrow **2**.
- › Use the screwdriver to remove and replace the battery in the area **C**.
- › Insert the battery cover in the opposite direction to arrow **2** until it audibly clicks into place.

Removable light



Fig. 346 Locking clip on the battery cover

Read and observe **!** on page 291 first.

- › Lever off the cover for the rechargeable batteries with a narrow and pointed object from the area of the lock clips **A** » Fig. 346.
- › Replace the batteries.
- › Insert the cover for the rechargeable batteries and press it down until it clicks into place.

! CAUTION

If an incorrect battery type is used or a non-rechargeable battery, there is a risk of damaging the light and the vehicle's electrical system.

Emergency unlocking / unlocking of doors

Unlocking/locking the driver's door

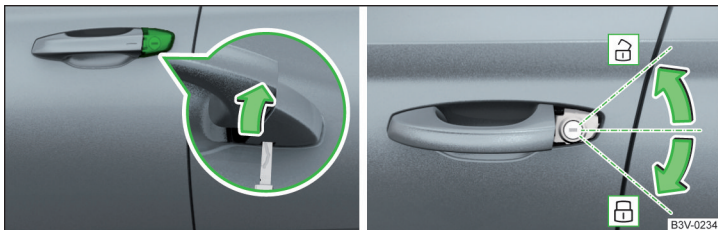

Fig. 347 Handle on the driver's door: Open/unlock and lock cover

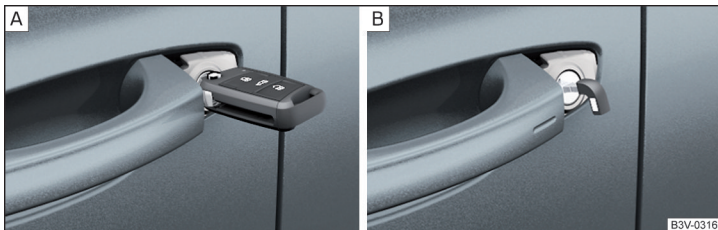

Fig. 348 Handle on the driver's door: Key with fold/out key bit/KESY key

The driver's door can be emergency unlocked / emergency locked using the key via the lock cylinder.

- › Pull on the door handle and hold.
- › Insert the key into the recess on the lower side of the cover and fold up the cover in the direction of arrow » Fig. 347.
- › Release the door handle.

- › For vehicles with **LHD**, insert the key with the fold-out key bit **with the buttons facing upwards** » Fig. 348 - [A] into the lock cylinder and unlock/lock the vehicle.
- › For vehicles with **RHD**, insert the key with the fold-out key bit **with the buttons facing downwards** into the lock and unlock/lock the vehicle.
- › On vehicles with the **KESY system**, insert the emergency key with the handle facing downwards » Fig. 348 - [B] into the lock cylinder and unlock/lock the vehicle.
- › Pull on the door handle and hold.
- › Replace the cover.

! CAUTION

Make sure you do not damage the paint when performing an emergency locking/unlocking.

Locking the door without locking cylinders

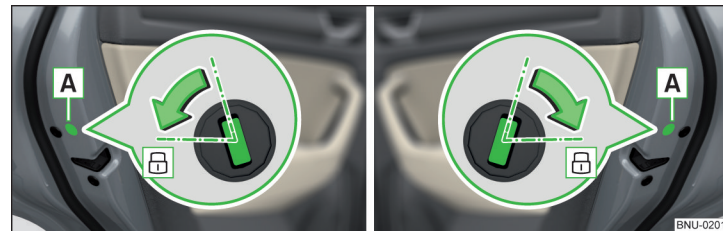

Fig. 349 Left door/right door:

- › Open the corresponding door.
- › In vehicles with the panel [A], remove this panel » Fig. 349.
- › Insert the key into the slot and turn in the direction of the arrow (sprung position).
- › Replace the cover [A].

After closing, the door is locked.

Unlock the boot lid

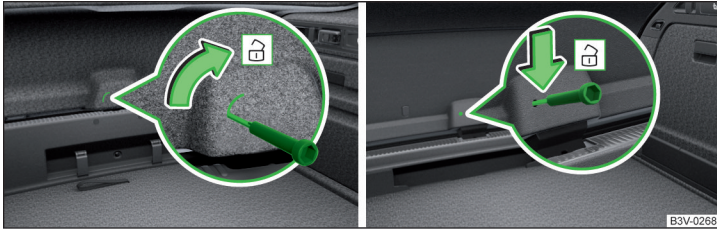

Fig. 350 Unlatch lid: Version 1/version 2

The boot lid can be unlocked manually from inside.

- › Insert a screwdriver or similar tool into the recess or the opening in the trim» Fig. 350 as far as the stop.
- › Unlock the lid by moving it in the direction of the arrow.

Selector lever emergency unlocking



Fig. 351 Remove / release the selector lever

- › Switch on the parking brake.
- › Open the stowage compartment in the front centre console.
- › Insert a flat-head screwdriver or similar tool into the gap in the arrow area **1**
 - › Fig. 351 and carefully lift the cover in the direction of arrow **2**.
- › Press on the yellow plastic part in the direction of arrow **3**, simultaneously press the lock button in the selector lever handle and put the lever in position **N**.

If the selector lever is moved again to position **P**, it is once again blocked.

! CAUTION

Make sure when lifting not to damage cover parts by the screwdriver in the shift lever environment.

Replacing windscreen wiper blades

! Introduction

! WARNING

Replace the windscreen wiper blades once or twice a year for safety reasons.

Replacing the windscreen wiper blades



Fig. 352
Setting the service position for the wiper arms



Fig. 353 Replace windscreen wiper blade

Read and observe **!** on page 294 first.

Before replacing the windscreen wiper blade, put the windscreen wiper arms into the service position.

Setting the service position

- › Switch the ignition on and off again.
- › Within 10 seconds, push the lever in the direction of arrow » Fig. 352 and hold for approximately 2 seconds.

Removing the wiper blade

- › Lift the wiper arm from the window in the direction of arrow **1** » Fig. 353.
- › Tilt the wiper blade to the stop in the same direction.
- › Hold the wiper arm and press the safety catch **A** in the direction of arrow **2**.
- › Remove the wiper blade in the direction of the arrow **3**.

Attaching the windscreen wiper blade

- › Push the windscreen wiper blade in the opposite direction of the arrow **3** until it locks into place. Check that the windscreen wiper blade is correctly attached.
- › Fold the windscreen wiper arm back to the windscreen.
- › Turn on the ignition and press the lever into the direction of the arrow » Fig. 352.

Move the windscreen wiper arms into the home position.

Replacing the rear window wiper blade

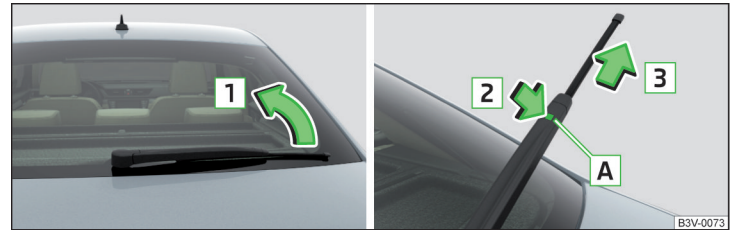

Fig. 354 Replace the rear window wiper blade

Read and observe **!** on page 294 first.

Removing the wiper blade

- › Lift the wiper arm from the window in the direction of arrow **1** » Fig. 354.
- › Tilt the wiper blade to the stop in the same direction.
- › Hold the wiper arm and press the safety catch **A** in the direction of arrow **2**.
- › Remove the wiper blade in the direction of the arrow **3**.

Attaching the windscreen wiper blade

- › Push the windscreen wiper blade in the opposite direction of the arrow **3** until it locks into place. Check that the windscreen wiper blade is correctly attached.
- › Fold the windscreen wiper arm back to the windscreen.

Fuses and light bulbs

Fuses

Introduction

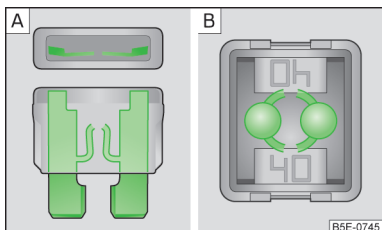

Fig. 355
Blown fuse

Individual electrical circuits are protected by fuses. A blown fuse is recognisable by the molten metal strip » Fig. 355 [A/B].

! WARNING

Always read and observe the warnings before completing any work in the engine compartment » page 269.

! CAUTION

- Replace the faulty fuse with a new one of the **same** amperage.
- If a newly inserted fuse blows after a short time, then seek the assistance of a specialist garage.
- Do “not repair” the fuses and do not replace them with stronger ones - it can cause a fire and could damage parts of the electrical system.

i Note

- We recommend always carrying replacement fuses in the vehicle.
- There can be several power consuming devices for one fuse. Multiple fuses may exist for a single power consuming device.

Fuses in the dashboard- LHD

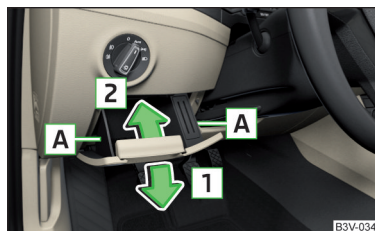

Fig. 356
Storage compartment on the driver's side

Read and observe ! and ! on page 296 first.

The fuse box is located behind the storage compartment on the driver's side.

Replacing fuses

- Remove the ignition key, turn off the lights and all electrical consumers.
- Open the storage box on the driver side.
- Hold the stacker laterally in the region [A] and open by pulling in the direction of arrow [1] (A greater force is required to open) » Fig. 356.
- Remove the plastic clip under the cover of the fuse box in the engine compartment » Fig. 360 on page 299.
- Use the clip to pull the fuse out, then insert a new fuse.
- Stow the clamp back in the original position.
- Close the compartment by pressing in arrow direction [2] until you hear it click.

Fuses in the dashboard- RHD



Fig. 357 Storage compartment on the front passenger side

Read and observe **I** and **II** on page 296 first.

The fuse box is located behind the storage compartment on the front passenger side.

Fold down the storage compartment and replace the fuse

- › Remove the ignition key, turn off the lights and all electrical consumers.
- › Open the storage compartment on the front passenger side.
- › Unlock the brake rod in the direction of arrow **1** and remove in the direction of arrow **2** » Fig. 357.
- › Press the detents **A** in the direction of arrow **3** and the compartment folds down in the direction of arrow **4**.
- › Remove the plastic clip under the cover of the fuse box in the engine compartment » Fig. 360 on page 299.
- › Use the clip to pull out the faulty fuse and then insert a new fuse.
- › Stow the clip back in the original position.

Fold back the storage compartment

- › Raise the tray in the opposite direction of arrow **4**.
- › Overcome the resistance of the detents **A**.
- › Insert the brake rod against the direction of arrow **2** and lock against the direction of arrow **1**.
- › Close the storage compartment.

Fuse assignment in the dashboard

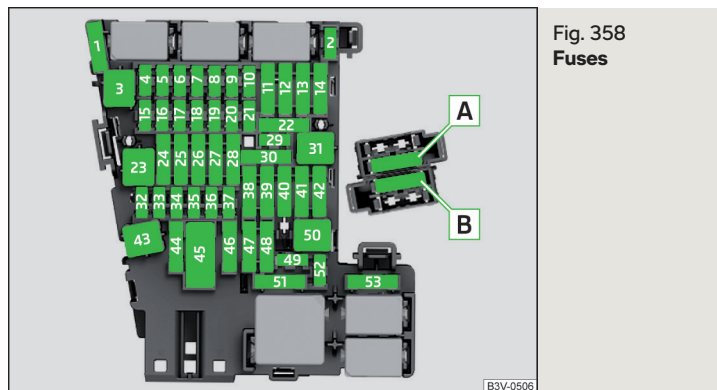

Fig. 358 Fuses

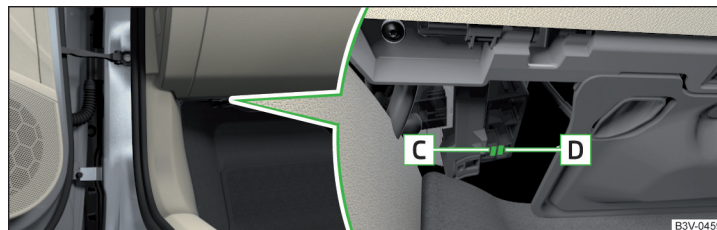

Fig. 359 Fuses for the USB charging function and front seat ventilation: RHD

Read and observe **I** and **II** on page 296 first.

No.	Consumer
1	SCR (AdBlue®)
2	Heated steering wheel
3	Not assigned
4	Anti-theft alarm

No.	Consumer
5	Databus
6	Automatic gearbox
7	Air conditioning, heating, receiver for the remote control for the auxiliary heating, heated rear window, heated windscreen, clock
8	Light switch, rain sensor, diagnostic connection, parking brake, ambient lighting, sensor of the alarm system, headlight
9	USB sockets
10	Infotainment screen
11	Light - left
12	Infotainment
13	Left side belt tensioner
14	Air blower for air conditioning, heating
15	Electric steering lock
16	Phonebox
17	Instrument cluster, emergency call
18	Reversing camera
19	KESSY system
20	SCR (AdBlue [®]), braking system
21	Four-wheel drive, air conditioning compressor
22	Tow hitch
23	Panoramic tilting / sliding sunroof
24	Light - right
25	Central locking - driver's door and rear left door, exterior mirror driver's side - heating, fold-in function, setting the mirror surface
26	Heated front seats
27	Xenon headlights, interior lights
28	Tow hitch
29	Operating lever underneath the steering wheel
30	Not assigned
31	Opening the boot lid
32	Parking aid (Park Assist)
33	Airbag switch for hazard warning lights

No.	Consumer
34	TCS, ESC, tyre pressure monitoring, air conditioning, reversing light switch, mirror with automatic dimming, START-STOP, heated rear seats, parking brake, light switch
35	Diagnostic connector, camera, radar sensor
36	Headlight right
37	Headlight left
38	Tow hitch
39	Central locking - front passenger door and right rear door, front passenger side mirrors - heating, fold-in function, setting the mirror surface
40	12-volt power outlets
41	Right side belt tensioner
42	Boot lid, headlight washers, windscreen washer system
43	Music amplifier
44	Tow hitch
45	Electrically adjustable seats
46	230-Volt power socket
47	Rear window wiper
48	Blind spot detection
49	Engine starting, clutch pedal switch
50	Not assigned
51	Heated rear seats, rear display, rear air conditioning
52	Shock absorber adjustment (adaptive suspension)
53	Heated rear window
A » Fig. 35 8	Front seat ventilation - left-hand drive
B » Fig. 35 8	USB charging - LHD

No.	Consumer
C » Fig. 35 9	USB charging - RHD
D » Fig. 35 9	Front seat ventilation - right-hand drive

Fuses in the engine compartment



Fig. 360 Fuse box cover: Removing the cover / Plastic clip for fuses

Read and observe **!** and **!** on page 296 first.

Replacing fuses

- › Remove the ignition key, turn off the lights and all electrical consumers.
- › Simultaneously press the lock buttons of the cover together in the direction of arrow **1** and remove the cover in the direction of arrow **2** » Fig. 360.
- › Remove the plastic clip under the cover of the fuse box » Fig. 360.
- › Use the clip to pull the fuse out, then insert a new fuse.
- › Stow the clamp back in the original position.
- › Replace the cover, push the lock buttons of the cover together and lock.

! CAUTION

The cover of the fuse box in the engine compartment must always be used correctly, otherwise water may penetrate into the fuse box – there is a danger of damage to the vehicle!

Fuse assignment in engine compartment

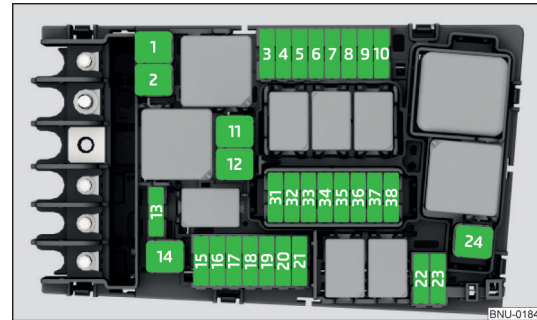

Fig. 361
Fuses

Read and observe **!** and **!** on page 296 first.

No.	Consumer
1	ESC, parking brake
2	ESC
3	Engine control system
4	Radiator fan, control valve for fuel pressure, electric auxiliary heating, glow plug system, air mass meter, engine components
5	Ignition, engine components
6	Brake sensor
7	Radiator shutters, coolant pump, crankcase ventilation, engine components
8	Lambda sensor, NOx sensor
9	Coolant pump, ignition, engine components
10	Fuel pump
11	Electrical auxiliary heating
12	Electrical auxiliary heating
13	Oil pump for automatic gearbox
14	Heated windscreen
15	Horn
16	Ignition

No.	Consumer
17	ESC, engine control unit, main relay coil
18	Databus, battery data module
19	Windscreen wipers
20	Not assigned
21	Automatic gearbox
22	Engine control system
23	Starter
24	Electrical auxiliary heating
31	Not assigned
32	Not assigned
33	Not assigned
34	Not assigned
35	Not assigned
36	Not assigned
37	Aux. heating
38	Not assigned

Bulbs

Introduction

This Owner's Manual only describes the replacement of bulbs where it is possible to replace the bulbs on your own without any complications arising. Other bulbs, Xenon gas-discharge lamps or LED lights must be replaced by a specialist garage.

For this reason, we recommend having bulbs replaced by a specialist garage or seeking other expert help in the event of any uncertainties.

- ▶ Switch off the ignition and all of the lights before replacing a bulb.
- ▶ Faulty bulbs must only be replaced with the same type of bulbs. The designation is located on the light socket or the glass bulb.

We recommend having the headlight settings checked by a specialist garage after replacing a bulb in the low, high or fog beam.

WARNING

- Always read and observe the warnings before completing any work in the engine compartment » [page 269](#).
- Accidents can be caused if the road in front of the vehicle is not sufficiently illuminated and the vehicle cannot or can only be seen with difficulty by other road users.
- H7 and H8 bulbs are pressurised and may burst when changing the bulb - risk of injury! We therefore recommended wearing gloves and safety glasses when changing a bulb.
- Do not carry out any work on the xenon gas discharge lamps - risk of death!

CAUTION

- Do not take hold of the glass bulb with naked fingers (even the smallest amount of dirt reduces the working life of the light bulb). Use a clean cloth, napkin, or similar.
- The cap of the filament bulb must always be seated correctly in the headlight, otherwise this may allow water and debris to enter the headlight - risk of damage to the headlights.

Note

We recommend that a box of replacement bulbs always be carried in the vehicle.

Bulb arrangement in the halogen headlights

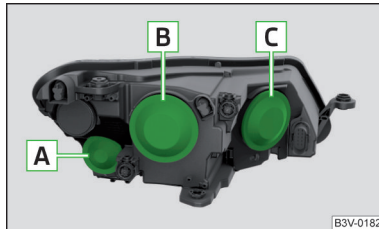

Fig. 362
Left headlight

Read and observe **I** and **II** on page 300 first.

Bulb arrangement » Fig. 362

- A** Flashing
- B** Low beam
- C** Main beam

Changing the bulb for the front turn signal light

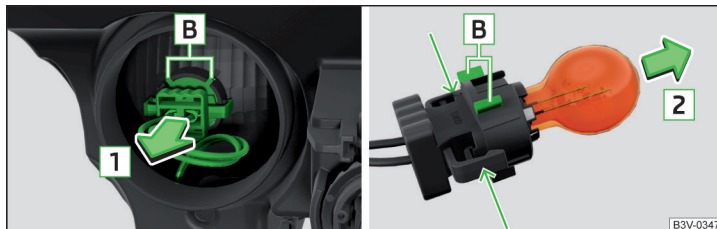

Fig. 363 Changing the bulb for the front turn signal light

Read and observe **I** and **II** on page 300 first.

- › Remove the protective cap **A** » Fig. 362 on page 301.
- › Remove the holder with the bulb by jiggling it out in the direction of the arrow **1** » Fig. 363.
- › Hold the holder with the bulb in the locations shown by the arrows.
- › Remove the faulty bulb from the holder in the direction of the arrow **2**.
- › Insert a new bulb in the holder until it stops.

- › Slide the holder with the bulb with the fixing lug **B** upwards so that it fits into the recess on the reflector.
- › Fit the protective cap **A** » Fig. 362 on page 301.

Removing bulbs for low and main beam

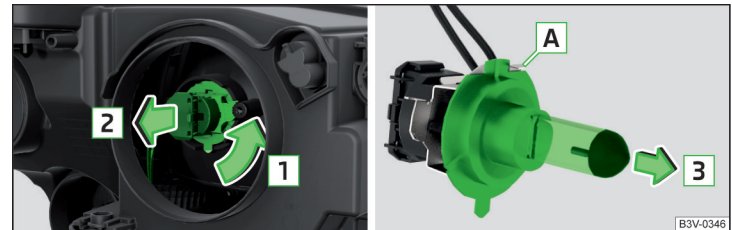

Fig. 364 Removing bulbs for low and main beam

Read and observe **I** and **II** on page 300 first.

- › Remove the protective caps **B** and **C** » Fig. 362 on page 301.
- › Turn the holder with the bulb in the direction of arrow **1** » Fig. 364.
- › Remove the holder with the bulb in the direction of arrow **2**.
- › Remove the bulb from the holder in the direction of the arrow **3**.
- › Insert a new bulb into the connector so that the lug **A** on the connector snaps into the groove on the bulb.
- › Insert the connector with the new bulb into the headlight in the opposite direction to the arrow **2**.
- › Turn the connector with the new bulb in the opposite direction to the arrow **1** until it stops.
- › Use the protective caps **B** and **C** » Fig. 362 on page 301.

Changing light bulbs for fog lights

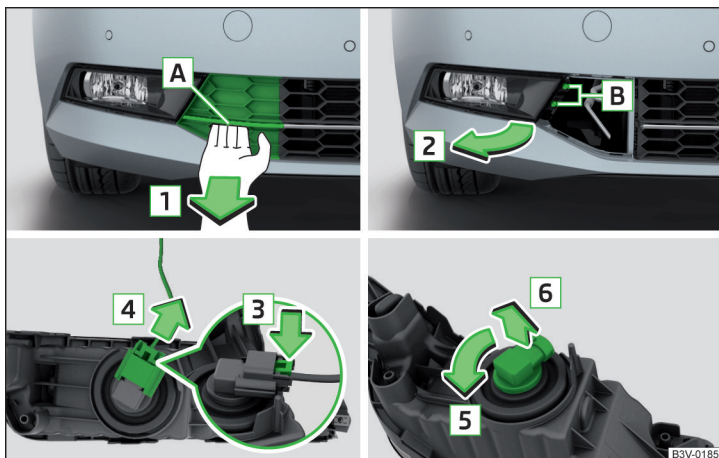

Fig. 365 Remove the number plate light / replace the bulb

📖 Read and observe **!** and **!** on page 300 first.

Remove the protective grille and headlight

- Insert your finger in the hole **A** and remove the grille by pulling in direction of arrow **1** » Fig. 365.
- Unscrew the screws **B** using the screwdriver from the tool kit.
- Remove the headlight in the direction of arrow **2**.

Replacing the light bulb

- Press the latch on the connector in the direction of arrow **3**.
- Remove the key in the direction of the arrow **4**.
- Turn the holder with the bulb to the stop in the direction of arrow **5**.
- Remove the holder with the bulb in the direction of arrow **6**.
- Insert a new holder with the bulb in the headlamp and turn it in the direction of arrow **5** as far as the stop.
- Attach the connector.

Refit the headlight and grille

- Replace the fog light by inserting it in the opposite direction of the arrow **2** » Fig. 365 and tighten.
- Insert the guard and push it gently until it locks into place.

Removing/installing tail light

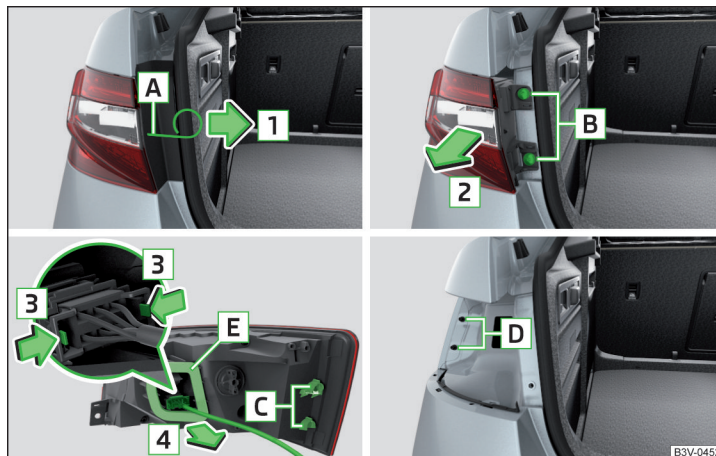

Fig. 366 Removing light / pulling out connector

📖 Read and observe **!** and **!** on page 300 first.

Removing

- Open the boot lid.
- Insert the clamps for removing the full wheel trims into opening **A** » Fig. 366.
- Remove the cover by pulling the hook in the direction of arrow **1**.
- Unscrew the screws **B** using the screwdriver from the tool kit.
- Hold the light and carefully remove in the direction of arrow **2**.
- Press the latches on the connector in the direction of arrow **3**.
- Carefully remove the connector from the lamp assembly in the direction of the arrow **4**.

Fitting

- › Slide the plug in the opposite direction of the arrow **4** » Fig. 366 into the light. The locks on the plug must be inserted securely.
- › Insert the light with the openings **D** onto the studs **C** in the body and carefully press in the light » **4**.
- › Screw the tail lamp into place and install the cover. The cover must engage securely.

! CAUTION

- Ensure that when re-inserting the light the wiring harness between the body and the light is not jammed and the seal **E** » Fig. 366 is correctly inserted - Otherwise there is a risk of water ingress and damage to the electrical installation.
- Ensure that the vehicle paintwork and the tail lamp are not damaged when removing and installing the lamp.

Replacing the bulbs in the rear light

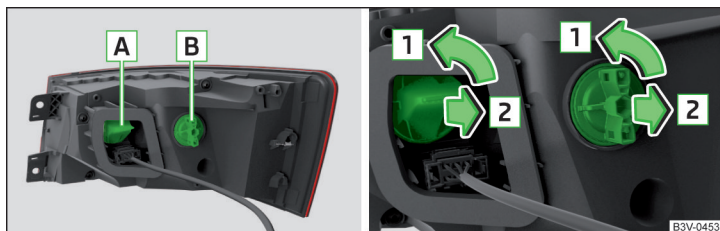

Fig. 367 Tail light / bulb replacement

! Read and observe **!** and **!** on page 300 first.

- › Turn the holder with the bulb **A** or **B** » Fig. 367 in the direction of the arrow **1**.
- › Remove the socket with the bulb from the lamp housing in the direction of arrow **2**.
- › Push the faulty bulb into the holder, turn in **anti** -clockwise direction up to the stop and remove.
- › Insert a new bulb into the holder and turn in a **clockwise direction** to the stop.

- › Reinsert the holder with the bulb into the lamp housing and turn in the opposite direction of the arrow **1** to the stop.

Technical data

Technical data

Basic vehicle data

Introduction

The details given in the vehicle's technical documentation always take precedence over the details in the Owner's Manual.

The listed performance values were determined without performance-reducing equipment, e.g. air conditioning system.

The values given have been determined in accordance with the rules and conditions specified in statutory or technical regulations for determining operational and technical data for motor vehicles.

The values listed are for the basic model without any optional equipment.

Vehicle data

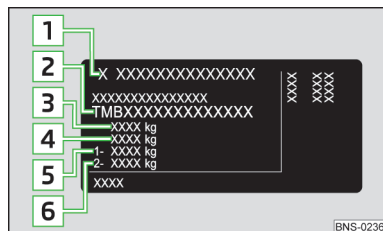

Fig. 368
Rating plate

Type plate

The rating plate » Fig. 368 is located at the bottom of the B-column on the right-hand driver's side.

The type plate contains the following data.

- 1 Vehicle manufacturers
- 2 Vehicle identification number (VIN)
- 3 Maximum permissible gross weight
- 4 Maximum permissible towed weight (towing vehicle and trailer)

5 Maximum permissible front axle load

6 Maximum permissible rear axle load

Vehicle identification number (VIN)

The vehicle identification number - VIN (vehicle body number) is stamped into the engine compartment on the right hand suspension strut dome. This number is also located on a sign on the lower left hand edge below the windscreen (together with a VIN bar code), and on the type plate.

The VIN can also be displayed in the → → **Events** menu.

Engine number

The engine number is embossed in the engine block.

Supplementary Information (applies to Russia)

The full type approval number of the means of transport is indicated in the registration documents, field 17.

Maximum permissible towed weight

The listed maximum allowable trailer weight is only valid for altitudes up to 1000 m above sea level.

The engine output falls as altitude increases, as does the vehicle's climbing power. Therefore, for every additional 1000 m in height (or part), the maximum permissible towed weight must be reduced by 10%.

The towed weight is made up of the actual weights of the loaded towing vehicle and the loaded trailer.

! WARNING

Do not exceed the specified maximum permissible weights – risk of accident and damage!

Operating weight

This value is only a guide value and corresponds to the lowest possible operating weight without further weight-reducing equipment (e.g. spare wheel etc.). This includes 75 kg driver's weight, the weight of the operating fluids and the on-board tool kit and a fuel tank filled to min. 90%. ▶

Operating weight - Superb

Engine	Transmission	Operating weight (kg)
1.4 l/110 kW TSI	MG	1428
	DSG	1443
1.5 l/110 kW TSI	MG	1452
	DSG	1467
1.8 ltr./132 kW TSI	DSG	1490
2.0 l/162 kW TSI	DSG (EU6)	1510
	DSG (EU4)	1510
2.0 l/200 kW TSI	DSG 4x4	1629
2.0 l/206 kW TSI	DSG 4x4	1620
1.6 l/88 kW TDI CR	MG	1518
	DSG	1530
2.0 ltr./110 kW TDI CR	MG	1540
	DSG	1560
2.0 ltr./130 kW TDI CR	DSG	1535
2.0 ltr./140 kW TDI CR	DSG	1573
	DSG 4x4	1655

Operating weight - Superb Estate

Engine	Transmission	Operating weight (kg)
1.4 l/110 kW TSI	MG	1450
	DSG	1465
1.5 l/110 kW TSI	MG	1474
	DSG	1489
1.8 ltr./132 kW TSI	DSG	1512
2.0 l/162 kW TSI	DSG (EU6)	1532
	DSG (EU4)	1532
2.0 l/200 kW TSI	DSG 4x4	1651
2.0 l/206 kW TSI	DSG 4x4	1642
1.6 l/88 kW TDI CR	MG	1540
	DSG	1552

Engine	Transmission	Operating weight (kg)
2.0 ltr./110 kW TDI CR	MG	1562
	DSG	1582
2.0 ltr./130 kW TDI CR	DSG	1557
2.0 ltr./140 kW TDI CR	DSG	1595
	DSG 4x4	1677

i Note

If required, you can find out the precise weight of your vehicle at a specialist garage.

Payload

It is possible to calculate the approximate maximum payload from the difference between the permissible total weight and the operating weight.

The payload consists of the following weights.

- ▶ The weight of the passengers.
- ▶ The weight of all items of luggage and other loads.
- ▶ The weight of the roof load including the roof rack system.
- ▶ The weight of the equipment that is excluded from the operating weight.
- ▶ Trailer bearing load for trailer towing » [page 254](#).

Measurement of fuel consumption and CO₂ emissions according to ECE Regulations and EU Directives

The data on fuel consumption and CO₂ emissions were not available at the time of going to press.

The valid specifications for your vehicle can be found in the technical vehicle documentation (e.g. vehicle approval documentation, the COC document) or at a ŠKODA partner.

i Note

- The emission and fuel consumption values have been determined in accordance with rules and under conditions set out by legal or technical requirements for determining operational and technical data for motor vehicles.
- Depending on the range of equipment, style of driving, traffic situation, weather influences and vehicle condition, consumption values may deviate from the indicated values.

Dimensions - Superb

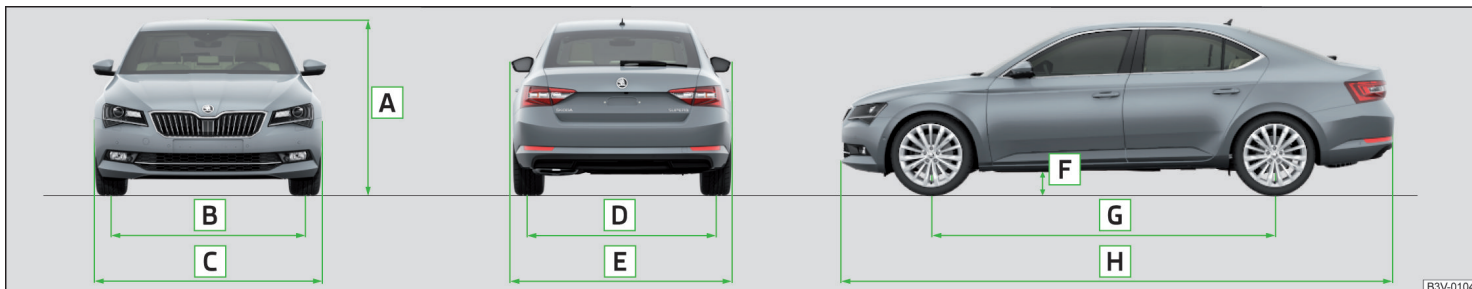

Fig. 369 Vehicle dimensions

The vehicle dimensions given in the vehicle's technical documentation always take precedence over the details in the Owner's Manual. The dimensions listed below are for the basic model without any optional equipment.

Vehicle dimensions for operating weight without driver (in mm)

» Fig. 369	Specification	Value	
A	Height	1468	
B	Front track	Basic dimension	1584
		Vehicles with the 2.0 I/162 kW TSI, 2.0 I/200 kW MPI and 2.0 I/206 kW TDI CR engine	1586
C	Width	1864	
D	Rear track	Basic dimension	1572
		Vehicles with the 2.0 I/162 kW TSI, 2.0 I/200 kW MPI and 2.0 I/206 kW TDI CR engine	1574
E	Width including exterior mirror	2031	
F	Clearance	149- 148 ^{a)}	
G	Wheel base	2841	
H	Length	4861	

^{a)} Applies to Superb 4x4 vehicles.

Dimensions - Superb estate

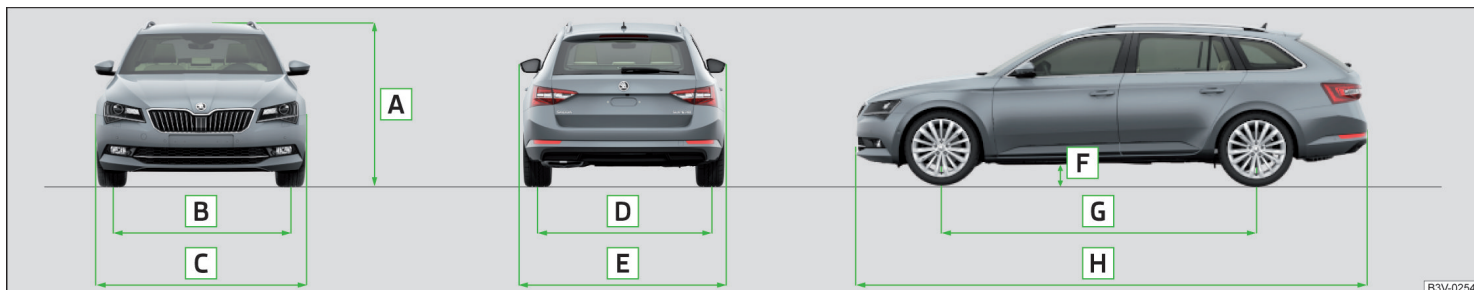

Fig. 370 Vehicle dimensions

The vehicle dimensions given in the vehicle's technical documentation always take precedence over the details in the Owner's Manual. The dimensions listed below are for the basic model without any optional equipment.

Vehicle dimensions for operating weight without driver (in mm)

» Fig. 370	Specification	Value	
A	Height	1477	
B	Front track	Basic dimension	1584
		Vehicles with the 2.0 l./162 kW TSI and 2.0 l./200 kW TSI engine	1586
C	Width	1864	
D	Rear track	Basic dimension	1572
		Vehicles with the 2.0 l./162 kW TSI and 2.0 l./200 kW TSI engine	1574
E	Width including exterior mirror	2031	
F	Clearance	149- 148 ^{a)}	
G	Wheel base	2841	
H	Length	4856	

^{a)} Does not apply to Superb Estate 4x4 vehicles.

Overhang angle

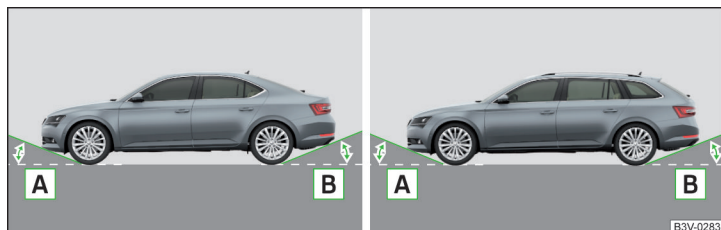

Fig. 371 Overhang angle: Superb/Superb Combi

Angle » Fig. 371

A Approach angle

B Departure angle

The values shown indicate the maximum incline of an embankment, up which the vehicle can drive at a slow speed without collision of the bumper or underbody. The values listed represent the maximum axle load at the front and rear.

Overhang angle (°) - Superb

» Fig. 371	A	B
Base value	14.0- 14.1 ^{a)}	12.2

^{a)} Applies to Superb 4x4 vehicles.

Overhang angle (°) - Superb Estate

» Fig. 371	A	B
Base value	14.0- 14.1 ^{a)}	12.2- 12.0 ^{a)}

^{a)} Does not apply to Superb Estate 4x4 vehicles.

Vehicle-specific details per engine type

Introduction

The specified values have been determined in accordance with rules and under conditions set out by legal or technical requirements for determining operational and technical data for motor vehicles.

The exhaust gas standard is specified in the vehicle's technical documentation, as well as in the declaration of conformity (in so-called COC document). The declaration of conformity (the so-called. COC document) can be obtained from a ŠKODA Partner (only valid for some countries and some models).

1.4 I/110 kW TSI engine

Output (kW at rpm)	110/5000-6000			
Maximum torque (Nm at rpm)	250/1500-3500			
Number of cylinders/displacement (cm ³)	4- 1395			
Body	Superb		Superb Estate	
Transmission	MG	DSG	MG	DSG
Top speed (km/h)	217	216	209	208
with the mentioned gear engaged	(5)	(5)	(5)	(5)
Acceleration 0-100 km/h (s)	8.7	8.9	8.8	9.0

1.5 I/110 kW TSI engine

Output (kW at rpm)	110/5000-6000			
Maximum torque (Nm at rpm)	250/1500-3500			
Number of cylinders/displacement (cm ³)	4- 1498			
Body	Superb		Superb Estate	
Transmission	MG	DSG	MG	DSG
Top speed (km/h)	217	216	210	209
with the mentioned gear engaged	(5)	(5)	(5)	(5)
Acceleration 0-100 km/h (s)	8.7	8.9	8.8	9.0

1.8 I/132 kW TSI engine

Output (kW at rpm)	132/5100-6200	
Maximum torque (Nm at rpm)	250/1250-5000	
Number of cylinders/displacement (cm ³)	4- 1798	
Body	Superb	Superb Estate
Transmission	DSG	DSG
Top speed (km/h)	230	222
with the mentioned gear engaged	(6)	(6)
Acceleration 0-100 km/h (s)	8.1	8.2

2.0 I/162 kW TSI engine

Output (kW at rpm)	162/4500-6200	
Maximum torque (Nm at rpm)	350/1500-4400	
Number of cylinders/displacement (cm ³)	4- 1984	
Body	Superb	Superb Estate
Transmission	DSG	DSG
Top speed (km/h)	243	234
with the mentioned gear engaged	(5)	(5)
Acceleration 0-100 km/h (s)	7.0	7.1

2.0 I/200 kW TSI engine

Output (kW at rpm)	200/5500-6500	
Maximum torque (Nm at rpm)	350/2000-5400	
Number of cylinders/displacement (cm ³)	4- 1984	
Body	Superb	Superb Estate
Transmission	DSG 4x4	DSG 4x4
Top speed (km/h)	250	250
with the mentioned gear engaged	(6)	(6)
Acceleration 0-100 km/h (s)	5.5	5.6

2.0 I/206 kW TSI engine

Output (kW at rpm)	206/5600-6500		
Maximum torque (Nm at rpm)	350/1700-5600		
Number of cylinders/displacement (cm ³)	4- 1984		
Body	Superb		Superb Estate
Transmission	DSG 4x4		DSG 4x4
Top speed (km/h)	250		249
with the mentioned gear engaged	(6)		(6)
Acceleration 0-100 km/h (s)	5.7		5.8

1.6 I/88 kW TDI CR engine

Output (kW at rpm)	88/3600-4000			
Maximum torque (Nm at rpm)	250/1750-3500			
Number of cylinders/displacement (cm ³)	4- 1598			
Body	Superb		Superb Estate	
Transmission	MG	DSG	MG	DSG
Top speed (km/h)	202	201	194	194
with the mentioned gear engaged	(6)	(7)	(6)	(7)
Acceleration 0-100 km/h (s)	11.2	11.3	11.4	11.5

2.0 I/110 kW TDI CR engine

Output (kW at rpm)	110/3500-4000			
Maximum torque (Nm at rpm)	340/1700-3000			
Number of cylinders/displacement (cm ³)	4- 1968			
Body	Superb		Superb Estate	
Transmission	MG	DSG	MG	DSG
Top speed (km/h)	219	217	212	209
with the mentioned gear engaged	(6)	(7)	(6)	(7)
Acceleration 0-100 km/h (s)	9.2	9.2	9.3	9.3

2.0 I/130 kW TDI CR engine

Output (kW at rpm)	130/3600-4000	
Maximum torque (Nm at rpm)	350/1500-3500	
Number of cylinders/displacement (cm ³)	4- 1968	
Body	Superb	Superb Estate
Transmission	DSG	DSG
Top speed (km/h)	226	217
with the mentioned gear engaged	(6)	(6)
Acceleration 0-100 km/h (s)	8.5	8.6

2.0 I/140 kW TDI CR engine

Output (kW at rpm)	140/3500-4000			
Maximum torque (Nm at rpm)	400/1750-3250			
Number of cylinders/displacement (cm ³)	4- 1968			
Body	Superb		Superb Estate	
Transmission	DSG	DSG 4x4	DSG	DSG 4x4
Top speed (km/h)	234	228	224	221
with the mentioned gear engaged	(7)	(7)	(7)	(7)
Acceleration 0-100 km/h (s)	8.3	8.0	8.4	8.1

Index		
A		
A2DP/AVRCP	165	
Abort route guidance	196	
ABS	42, 218	
ACC	47	
see Automatic Distance Control	236	
Accessories	259	
Activation of online services	14	
Active steering assist (DSR)	218	
Adaptive chassis (DCC)	48, 244	
Adaptive cruise control		
Operation	237	
Set/change the desired speed	240	
Start control	239	
Warning light	40	
Adaptive Cruise Control	47	
automatic stopping and starting	238	
Malfunctions	241	
Overtaking	241	
Radar sensor	216	
Setting the distance	240	
Special driving situations	240	
Stop/resume control	239	
Trailer towing	241	
Adaptive headlight		
see xenon headlight	72	
AdBlue	267	
Check level	268	
indicator light	46	
refill	268	
Additional keypad languages	137, 144	
additional window	183	
Adjusting		
Steering wheel	21	
Adjusting seats manually	83	
Advice on tyre/wheel usage	276	
AHL		
See xenon headlight	72	
aim		
Favourite	186	
Flagged destination	186	
Online goals	186	
own goal	188	
saved destination	186	
search	183	
Telephone contact	186	
vCard	186	
Air-conditioning system		
Air outlet vents	121	
Airbag	25	
Adjustments and impairments on the airbag system	260	
Deactivation	27	
Deployment	25	
Warning light	42	
Airbag system	25	
Air conditioning	117	
Air Care	121	
Air distribution control	120	
Climatronic	118	
Manual air conditioning	117	
Air distribution control	120	
Air outlet vents	121	
Alarm	62	
Trailer	258	
All season tyres	279	
Alphanumeric with keyboard	129	
Alternative routes	142	
Ambient lighting	77	
Amundsen		
external module	127	
Infotainment description	126	
Android Auto	176	
Anti-lock brake system (ABS)	218	
Anti-theft alarm system	62	
Trailer	258	
Anti-theft wheel bolts	285	
APN	138, 166	
Apple CarPlay	177	
applications		
Disclaimer	125	
Armrest		
Front	86	
rear	99	
Rear	87	
Ashtray	102	
ASR	218	
Assistant for emergencies	249	
Assist systems	216	
AT THE	147	
Audio source	152	
Auto-Check-Control		
Vehicle condition	49	
Auto Hold	44, 209	
Auto Hold function	44, 209	
Automatic consumer shutdown	274	
Automatic distance control		
activate	239	
Operational overview	239	
Automatic Distance Control	236	
Settings in Infotainment	237	
Automatic drive		
Kickdown	213	
Selector lever	212	
Automatic driving light control	72	
Automatic gearbox		
Launch control	214	
Malfunction	44	
Manual shifting on the multifunction steering wheel	213	
Release gear selector lever	212	

Selector lever emergency unlocking	294
Selector lever lock	212
Start and run	213
Tiptronic	213
Warning light	44
Automatic switch-off of Infotainment	130
Automatic transmission	211
Auxiliary heating (auxiliary heating and ventilation)	122
In infotainment	123
Radio remote control	123
set to	122
Avoiding damage to your vehicle	215
B	
Bass tones	136
Battery	
Changing batteries for the removable light	292
Changing in key	291
Replace the battery in the remote control in the auxiliary heating	292
Belts	22
Belt tensioners	24
reversible	24
Blanket	100
Blind spot monitoring assistant	
Activation / deactivation	225
Bluetooth	
A2DP / AVRCP	138
Name	138
on / off	138
Paired external devices	138
Profiles	165
rSAP	163
Set	145
set to	138, 140
Set to	138
Switch on/off	145
Update	135, 138

Updates	145
Visibility	138, 145
Bluetooth Player	154
Bluetooth® update	163
Bolero	
external module	127
Infotainment description	126
Bonnet	270
Boot lid	64
Automatic locking	63
Open/close	63, 64
See boot lid	63
Brake Assist (HBA)	219
Brake booster	208
Brake fluid	273
Check	273
specification	273
Brake linings	
Warning light	43
Brake pads	
new	208
Brake pedal (automatic gearbox)	
Warning light	44
Brakes	
Brake booster	208
Brake fluid	273
Braking and stabilisation systems	217
Information on braking	208
Parking brake	208
Running in	214
Warning light	40
Brake system	217
Breakdown call	167
Broadcasting	147
Bulbs	
Replacing	300
Buttons on the driver door	
Electric windows	66

C

Call list	
Call list	169
CAR	202
Car battery	
automatic consumer shutdown	274
Check condition	275
Cover	275
Disconnecting and reconnecting	275
Replacing	275
Winter operation	275
Car care	260
Interior	264
Car computer	
see multifunction display	51
Care and maintenance	259
Care Connect	17
Cargo element	110
Car park	185
Carrier	116
CarStick	172
Car wash	260
CD	152
cellphone	
Disclaimer	125
Central locking	57
Problems	62
Central locking button	59
Changing	
Batteries for the removable light	292
Battery	291
Wheels	283
Windscreen wiper blades	295
Changing a wheel	283
Changing gear	
Selector lever	212
Tiptronic	213

Charging a vehicle battery	275	compartments	92	Data connection	
Check		Compatible sources		Amundsen	172
Brake fluid	273	Pictures	157	CarStick	172
Engine oil	271	Video DVD	159	Internet	172
Oil level	271	Component protection	260	rSAP	173
Checking		Computer		Data Connection	
Battery status	275	see multifunction display	51	Columbus	172
Coolant	272	Conditions for pairing	163	SIM card	173
Children and safety	29	Conference call	169	Data roaming	138
Child safety lock	61	Configuration wizard	132	Data transfer of external devices	132
Child seat	29	Connect external device to the Infotainment hotspot	174	Date	136, 144
Classification	31	Connect Infotainment to the hotspot of the external device	174	DAY LIGHT	
I-Size	33	Convenience operation		see Daytime running lights	71
Installation location	31, 33	Tilting / sliding sunroof	69	Daytime running lights	71
ISOFIX	32	Coolant	272	DCC	48, 244
on the front passenger seat	29, 30	Checking	272	De-icing the windscreen and rear window	77
Place of installation	32	Refilling	272	Deactivation	
TOP TETHER	33	Temperature display	36	Airbag	27
Cigarette lighter	103	Warning light	45	default settings	202
Cleaning the vehicle		CORNER	73	Default settings	137
Interior	264	Correct routing of seat belt	22	Delayed locking of the boot lid	
Outside	262	19, 21	See boot lid	63
Washing	261	Correct seating position	19, 21	Delete destination	193
Climatronic	117	Crew Protect Assist	246	Demo mode	143, 194
air distribution control	120	Cruise control		Destination	
Automatic operation	120	activate	234	Enter destination using the address	184
Operate in Infotainment	119	lever	234	enter in map	185
Operating elements	118	Cruise Control System	234	Favourite	193
Clock		Cup holders	94	final destinations	186
Change display	130	D		Home address	187
Clothes hook	98	DAB	147	Image with GPS	189
Cockpit	35	additional information	147	Map point	185
Lighting	75	Radio Text and images presentation	147	Memory	193
Columbus		Set	139, 146	Types of destination search/destination entry	183
external module	127	DAB Slideshow	147	Destination details	193
infotainment Description	125				
Comfort indicating	71				
COMING HOME	73				

Destination management	
Destination details	193
Favourite	193
Storage	193
Diesel	267
Diesel fuel	267
Digital clock	49
Digital instrument cluster	37
Code options	38
Display	38
Map	192
Sets the map display	142
Turn the map display on / off	182
Digital service schedule	54
Dipped beam	70
Dipstick	271
Directive 2014/53/EU	9
Disclaimer	
applications	125
external devices	125
Mobile phones	125
Display	
Coolant temperature	36
Fuel level	37
Gear changes	49
In the instrument cluster	48
Rear centre console	37
Display information on sporty driving in Info-tainment	50
Display of a low temperature	47
Display of the instrument cluster	
Menus in the display of the instrument cluster	53
Display POIs in the map	185
Display when the light is switched off	
indicator light	46
Distance warning	242
Diverting calls	140

Door	
Child safety lock	61
Emergency locking	293
Emergency locking of the driver's door	293
Open / Close	61
Door alarm	48
Drive	
Driving through water	216
DriveGreen	214
Driver information system	48
Driving	
Emissions	305
Fuel consumption	305
Maximum speed	309
through water	216
Driving mode	244
Adaptive chassis (DCC)	244
Comfort	245
Eco	244
Individual	245
Mode selection and Infotainment display	245
Normal	245
Settings for individual mode	246
Sports	245
Driving Mode Selection	244
DSR	218
DVD	152
DVD-Video	
Select video source	158
Set to	140
Dynamic Light Assist	74
Dynamic Road Sign Display	
Additional display	251
Information messages	252
Malfunctions	252
Operation	251
Settings in Infotainment	250
Dynamic route	201

E	
Economical driving	214
Economy mode	
Warning light	48
Edit route	196
EDR	8
EDS	218
Electrical boot lid	
set the top position of the lid	65
Electrical power windows	67
Electric boot lid	
Force limiter	64
Manual operation	64
Open/close	64
Electric parking brake	208
Electric power windows	66
Malfunctions	68
Electric tail gate	
Malfunctions	65
Electric windows	
Buttons on the driver door	66
Electronic Differential Lock (EDL, XDS)	218
Electronic immobilizer	204
Elevation	180
emergency	
Jump-starting	288
Starting the engine / stopping the push of a button	206
Emergency	
Changing a wheel	283
Hazard warning light system	73
Jump-starting	288
Selector lever release	294
Starting the engine / stopping the engine at the push of a button	205
Towing the using the tow hitch	291
Towing the vehicle	289
Tyre repair	286

Unlocking/locking the door	293	External device data transfer	137, 144	Fog lights	73
Unlocking / locking the door	293	External devices		Warning light	44
Emergency call	16, 167	Disclaimer	125	Fog lights/rear fog light	73
Emergency equipment		External module	127	Foils	262
Fire extinguisher	282	CD / DVD	152	Force limiter	
First aid kit	281	SD card	153	Electric boot lid	64
Jack	282	SIM card	166	Sliding/tilting sunroof	69
Reflective vest	281	Video DVD	158	Tilting / sliding sunroof	68
Vehicle tool kit	282			Window	67
Warning triangle	281			Front assist	
Emission control system	42	F		Warning light	47
Emissions	305	Factory settings	145	Front Assist	242
Engine		Familiarizing yourself with the vehicle	2	Disable/enable	243
Information messages	45	Fastening elements	105	Distance warning	242
Running in	214	Fatigue detection		Malfunctions	244
Engine compartment	269	Fatigue detection system	252	Operation	242
Brake fluid	273	Fatigue detection system	252	Radar sensor	216
Coolant	272	Favourite	186, 193	Settings in Infotainment	242
Engine oil	271	File formats		Warning and automatic braking	243
Overview	270	Media	155	Warning light	47
Vehicle battery	274	Pictures	157	Front head restraints	
Windscreen washer fluid	271	Requirements and Restrictions	155	Adjust height	88
Engine drag torque control (MSR)	218	Video DVD	159	Front seats	83
Engine number	304	Find		Fuel	265
Engine oil	271	Car park	185	Diesel	267
Check	271	Petrol station	185	Fuel gauge	37
Oil changing	271	Restaurant	185	refer to Fuel	265
Refilling	271	Finish route guidance	195	Refuelling	265
specification	271	Fire extinguisher	282	Unleaded petrol	266
Warning light	45	First aid kit	281	Warning light	43
Engine revolutions counter	36	Flagged destination	186	Fuel consumption	305
Enter destination	184, 185	Flashing	71	Fuel filter	47
EPC	42	Floor covering in the luggage compartment	107	Fuel reserve	43
equalizer	136	Flooring in the luggage compartment	107	Functional surfaces	128
ESC		Floor mats	211	Fuses	296
ESC Sport	217	See Floor mats	211	in the dashboard	296, 297
Operation	217	FM	147	in the engine compartment	299
Event Data Recorder	8	Set	139, 145	Plastic clip	299

G	
Gearbox	
Information messages	44
Gear change	
Gear recommendation	49
Information on the selected gear	49
Gear changing	
lever	211
Genuine parts	259
Glasses storage box	96
GPS	180
Graphical driving recommendations	195
H	
hand gestures	130
Hazard warning light system	73
HBA	219
Headlight assistant	74
Warning light	47
Headrests	88
Heating	117
Air distribution control	120
Mirrors	82
Seats	89
Steering wheel	91
Windscreen and rear window	77
Hill Start Assist	219
hitch	255
Hitch	254
Home address	142, 187
HOME button	132
HOME main screen	132
Hook	106
Horn	35
Hotspot	
Connect	174
Set	174

I	
I-PAD holder	103
I-Size	33
Ignition lock	205
Images	
Display	140
main menu	156
safe removal of the data source	137
Select Image Source	156
service	157
Set to	140
Image viewer	156
Immobilizer	204
import	
Destinations (online)	189
Objectives (vCard)	188
POI categories	188
POI categories (online)	181, 189
Routes (online)	197
Import contacts	140
In-car communication	
See Electronic voice amplification	131
Inertia reels	24
Information about the towing process	289
Information call	167
Information system	48
Gear recommendation	49
Menus in the display of the instrument cluster	53
Multifunction display	51
Service interval display	54
infotainment Description	
Columbus	125
Infotainment description	
Amundsen	126
Bolero	126
Swing	127
Infotainment gesture control	130

Infotainment language	137, 144
Infotainment menus	
Grid display	131
Horizontal display	131
Infotainment Online	18
Infotainment operation	128
Infotainment screen	128
Infotainment operation using an application in the external device	132
Infotainment Overview	125
Infotainment restart	130
Infotainment screen	136, 144
Areas	128
Important information	127
keyboard	129
Maintenance	127
Operation	128
Infotainment system	125
Input screen	
Language characters	144
Input screen with keyboard	129
Instrument cluster	36
Digital	37
Vehicle condition	49
Warning lights	39
Interior light	76
Interior lighting	76
Interior lights	
Ambient lighting	77
Interior monitor	62
Intermediate target	193
Internet	172
Amundsen	172
CarStick	172
Columbus	172
rSAP	173
SIM card	173
ISOFIX	32

J		Laptimer	Headlight range control	70
Jack	282	infotainment	Parking lights	70
- fit	285	Last destinations	Switching on and off	70
Journey	52	Latitude	Warning lights	39
Jukebox	154	LEAVING HOME	List	
Jump-starting	288	lever	of available stations	148
K		ACC	of telephone contacts	167
KESY		Cruise control	With folder / track list	151
deactivating	59	Speed limiter with ACC	List of available hotspots	174
Starting engine / Stopping	205	Speed limiter with GRA	List of paired external devices	165
Switching the ignition on/off	205	Lever	List of traffic reports	200
Unlock / lock	59	Operation of the information system	Load	305
key		Turn signal/main beam	Location Services	16
Starting engine / Stopping	205	Windscreen wipers	Lock	
Key		Liability for defects	Individual settings	60
Changing battery	291	Light	KESY	59
Switching the ignition on/off	205	Cockpit	Locking	
Take out emergency key	58	COMING HOME / LEAVING HOME	Central locking button	59
keyboard	129	Daytime running lights	in case of emergency	293
key CAR	202	Flash	Remote control	58
L		Fog lights/rear fog light	Lock steering lock	204
L-band	139	Function CORNER	Long cargo channel	99
Lamp failure	46	Hazard warning light system	Longitude	180
Lamps		Headlight assistant	Luggage compartment	105
Warning light	46	Headlight cleaning system	Cover	107
Lan Departure Warning		Parking light	Fastening elements	105
Activation / deactivation	248	Replacing bulbs	Fastening the flooring	107
Lane Assist	44, 247	Turn signal/main beam	Fixing nets	106
Malfunctions	248	Xenon headlight	Floor covering on both sides	107
Settings in Infotainment	247	Light Assist	foldable hook	106
Lane Departure Warning		Lighting	Lighting	105
Operation	247	Ambient lighting	Net on the luggage compartment cover	107
Lane recommendation	195	Entry space	Net partition	115
Language characters	137	Interior lighting	Removable light	113
		Luggage compartment	Roll-up cover	108
		Lights	Side pockets	110
		Automatic driving light control	Storage compartments under the floor covering	111
		Dipped beam	tray with cargo element	110
		Driving abroad		

unlock manually _____	294	Manoeuvre	List _____	151
Unlock the boot lid _____	294	Graphical driving recommendations _____	Main menu _____	150
Variable loading floor _____	113	Nav. announcements _____	Multimedia database _____	151
Luggage compartment cover	107	Manual air conditioning	Playback control _____	150
Roll-up cover _____	108	Air distribution control _____	Requirements and Restrictions _____	155
Luggage storage		Controls _____	safe removal of the data source _____	137
Multi-function pocket _____	112	Manual gear changing	Safe removal of the data source _____	144
		See Gear changing _____	SD card _____	153
			Setting _____	140
M		Map	Set to _____	146
Main beam _____	71	automatic scale _____	Voice control _____	133
Warning light _____	44	Display _____	WLAN _____	154
main menu		Display options _____		
Android car _____	177	Display options in the split screen _____	Media Command	
Apple carplay _____	178	Display POIs _____	Control _____	160
Images _____	156	Fast Map _____	Main menu _____	160
MirrorLink® _____	178	in the digital instrument cluster _____	Supported formats _____	160
radio _____	147	Lane recommendations _____	Memory _____	53
Main menu		Main menu _____	Memory Function for the seat _____	85
Media _____	150	Manual scale _____		
Media Command _____	160	Map alignment _____	Menus in the display of the instrument cluster	53
Navigation _____	182	Operation _____	Apple CarPlay _____	54
SmartLink _____	176	POI display _____	audio menu item _____	54
SMS _____	170	Road Signs _____	Main menu _____	53
Video DVD _____	158	Traffic sign display _____	navigation menu item _____	54
Waypoint mode _____	198	Alignment _____	Operation _____	51
WLAN _____	173	Massage function of the driver's seat _____	phone Menu item _____	54
Make up mirror _____	78	Maximum speed _____	wizard menu item _____	54
Manage favourites _____	146	MCB _____	Mirror _____	78, 81
Manage Favourites _____	140	media	MirrorLink® _____	178
Manage memory _____	142	serve _____	MODE button	
Management of online services _____	15	USB _____	See driving mode _____	244
Management of online services ŠKODA Connect _____	145	Media	Modes of the automatic transmission _____	212
Management of ŠKODA Connect Online Services _____	138	Audio source _____	Modifications and technical alterations _____	259
Managing paired devices _____	165	Bluetooth Audio _____	Most common routes _____	195
Managing saved routes _____	197	Browser _____	MSR _____	218
		CD / DVD _____	Multi-function pocket _____	112
		Compatible sources _____	Multicollision brake (MCB) _____	219
		File formats _____	Multifunctional steering wheel _____	51
		Jukebox _____		

Multifunction display			
Functions	51	Home address	187
Information Overview	51	Image with GPS	189
Memory	53	Imported destinations	142
multimedia		Intermediate target	193
see media	150	Main menu	182
Multimedia database	151	Manage memory	142
Mute	131	Map	142
MyŠKODA App application	11	Map alignment	191
		Map display in the digital instrument cluster	192
		Map display options	190
		Map scale	190
		Most common routes	195
		Navigation data	181
		Navigation data update	181
		Nav. announcements	143, 195
		Options for map display in the split screen	192
		Preferred route type	142
		Route	193
		Route calculation	194
		Route change	197
		Route display	190
		Route display in the split screen	192
		Route guidance	193
		Route information	196
		Route options	142
		Route schedule	196
		Set to	142
		Start the route guidance	194
		Status line	143
		Tank options	143
		Top speeds	143
		Traffic obstruction	202
		Trailer towing	194
		Transit point	197
		Types of destination search/destination entry	183
		Update the navigation data	143
		Version information	143
		Voice control	133
		Waypoint mode	198
		navigation data	181
		Navigation data	181
		Navigation data update	181
		Nav. announcements	143, 195
		Net partition	115
		Nets	106, 107
		Network	
		Data connection	138
		Data roaming	138
		setting	138
		set to	140
		Values of the downloaded data	138
		New route	197
		Notes	12
		O	
		oil	
		see Engine oil	271
		Oil changing	
		Engine oil	271
		On-board computer	
		see multifunction display	51
		On-line	
		destination search	183
		Detail of the traffic report	201
		Import POI categories	181, 189
		route import	197
		target import	186, 189
		Update navigation data	181
		Online	
		Destination details	193
		Find car park	185
		Find petrol station	185
		List of traffic reports	200
		Navigation data update	181
		Online goals	186

Online services		Own POI categories	188, 189	Park pilot	219
Deleting the user	14	P		Particulate Filter	46
Electronic Owner's Manual	14	Pairing process	163	Part replacement	259
Instruction video	14	Park		Passive safety	
private mode	15	Rear traffic alert	223	Before setting off	19
service management	15	Park assist		Driving safety	19
Switching user	14	Parking	232	Passive Safety	19
Switch online services in the service workshop		Park Assist	229	Pedals	211
off/on	15	Automatic brake assist	233	Floor mats	211
Switch online services on/off in infotainment	15	Departing from a parallel parking space	233	Personalisation	
ŠKODA Connect Portal website	13	Malfunctions	233	Configuration wizard	132
Online Services	13	Operation	230	Personalization	55
Activation in Infotainment	14	Parking	233	Operating principle	56
Care Connect	17	Parking space search	231	Overview of some personalized functions	56
Infotainment Online	18	Switch to park mode	231	Set	56
Location Services	16	Park assistant		Petrol	266
proactive service	17	Activation/deactivation	225	Petrol station	185
Remote access to the vehicle	17	Parking	210	Petrol station logo	142
Service package	13	Park Assist	229	phone	
Status Symbols of Online Services	16	Parking sensors	219	connect to the infotainment	163
ŠKODA Connect website	13	Rear View Camera	226	couple	163
Online services ŠKODA Connect		Parking aid		Phone	
enable service	145	Automatic emergency braking	222	Adjust text messages	140
Opening/closing		automatic system activation when moving forward	222	Clear calls	140
contactless boot lid	65	Display in Infotainment screen	221	Diverting calls	140
opening/closing contactless boot lid	65	Operation	220	Import contacts	140
Operating the digital instrument cluster	38	Settings in Infotainment	220	Manage Favourites	140
Operating the Infotainment menus	129	Parking assistance		Phone call	169
Operating weight	304	Activation / deactivation	222	Premium	140
Operation		Parking brake	208	rSAP	163
Telephone	161, 162	Warning light	40	Settings call	140
Original accessories	259	Parking lights	70	set to	140
Overhang angle	308	Parking sensors	219	User profile	140
Overview		Parking the vehicle		Phonebox	93
Cockpit	35	see Parking	210	Phone call	169
Engine compartment	270	Parking ticket holder	92	Phone Premium	
Fuses	296			SIM card	166
Warning lights	39				

Pictures		Proactive service	17	Rear Traffic Alert	
Compatible sources	157	Puncture repair kit	286	Malfunctions	225
File formats	157			Operation	224
Requirements and restrictions	157	R		Rear View Camera	226
Supported file formats	157			Rear view mirror	81
Pin code		Radiator shutters	215	Rear window - heating	77
set to	140	radio		Record waypoints	199
Playback		Broadcasting	147	Refill	
Media	150	main menu	147	Windscreen washer fluid	271
Pockets	98	Radio stations Logo	148, 149	refilling	
POI	188, 189	scan	147	AdBlue	267
POIs	185	serve	147	Refilling	
Pop-up window		Radio		Coolant	272
Map	192	L-band	139	Engine oil	271
Power steering	41	List of available stations	148	Reflective vest	281
Practical equipment		Set	139, 145	Refuelling	265
230-volt socket	101	Traffic program (TP)	149	Fuel	265
Practical features		Voice control	133	Register online services	
12-volt socket in the interior	100	Radio equipment		settings	138, 145
12 volt socket in luggage compartment	101	Information on Directive 2014/53/EU	9	Registration of online services	
Ashtray	102	Radio remote control		Electronic Owner's Manual	14
Cigarette lighter	103	Auxiliary heating (auxiliary heating and ventilation)	123	Instruction video	14
Glasses storage box	96	Radio station	148	Regulation	
Parking ticket holder	92	Preset buttons	148	Headlight beam	70
Pockets	98	Radio station logos	148, 149	Remote access to the vehicle	17
Reflective vest	281	Update	138	Remote control	
Seat backrest with long cargo channel	99	radio stations		Changing battery	291
Storage compartment	92	Select channels and search	147	Synchronisation process	62
Storage compartment for umbrella	97	Raising the vehicle	285	Unlocking/locking	58
Storage compartment under the front passenger's seat	97	Rear fog light	73	Remote transfer of SIM data	163
Waste container	95	Warning light	42	Removable light	113
Preferred contacts	168	Rear headrests		Changing batteries	292
Preheating unit	42	Adjusting the height	88	Removable through-loading bag	99
Principles of Infotainment operation	128	Removing/inserting	89	Repairs and technical alterations	259
Private mode	15	Rear seats	87	Replace	
Proactive occupant protection	246	Rear traffic alert	223	Battery	292
Proactive passenger protection warning light	42				

Replacing	
Bulbs _____	300
Fuses _____	296
Windscreen wiper blades _____	294
Reproduction	
Video DVD _____	158
Reset counter for distance driven (trip) _____	48
Restaurant _____	185
Reversible belt tensioners _____	24
Rims _____	276
Road Signs	
infotainment display _____	192
Roller blind	
see Luggage compartment cover _____	108
Roof	
Load _____	116
Roof racks _____	116
route	
new route _____	197
Online Route Import _____	197
route list _____	197
Route _____	193
Store route _____	196
Route calculation _____	194
Trailer towing _____	194
Route information _____	196
route list _____	197
Route options _____	142
Route schedule _____	196
rSAP _____	163
Data connection _____	173
Running in	
Brake pads _____	208
Engine _____	214
Tyres _____	276

S

SafeLock _____	60
-----------------------	----

Safe removal of the data source _____	137, 144
Safety _____	19
Airbag _____	25
Child safety _____	29
Child seats _____	29
Correct seating position _____	19
Headrests _____	88
I-Size _____	33
ISOFIX _____	32
TOP TETHER _____	33
SAFE, SAFELOCK	
See SafeLock _____	60
Save radio	
Save channel _____	148
Saving electrical energy _____	214
Saving fuel _____	214
Scraper _____	263
Screen	
see Infotainment screen _____	127
Screen display _____	128
SD card _____	153
Safe removal _____	144
search	
aim _____	183
Online goals _____	183
Search	
Types of destination search/destination entry _____	183
Seat belt	
height adjustment _____	22
Warning light _____	40, 45
Seat belts _____	22
Belt tensioners _____	24
fastening and unfastening _____	23
Inertia reels _____	24
Seat electrical adjustment _____	84

Seats	
Convenience operation of the front passenger seat _____	85
Electrical adjustment _____	84
Folding front passenger seat _____	86
Front _____	83
Front armrest _____	86
Headrests _____	88
Heating _____	90
Manually adjusting _____	83
Massage function of the driver's seat _____	84
Memory Function of the electrically adjustable seat _____	85
Rear _____	87
Rear armrest _____	87
Rear seat backrests _____	87
Setting _____	83
Storing in memory of remote control key _____	85
Ventilation _____	90
see Instrument cluster	
see Instrument cluster _____	36
Selector lever _____	212
Selector lever control _____	212
Selector lever lock _____	44
service	
Images _____	157
media _____	150
radio _____	147
Service _____	259
Service interval display _____	54
Warning light _____	48
Service interval _____	54
Service interval display _____	54
Service intervals _____	54
Service schedule _____	54
Setting	
Headrests _____	88
Mirror _____	81, 82
Positions of the variable loading floor _____	113

Seat belt height	22	Pin code	140	Sliding/tilting roof	
Seats	83	Radio	139, 145	Activate operation	69
Time	49	Reset to factory settings	137	Activating operation of the sunblind	70
settings		Restore factory settings	145	Sunshade	70
Bass tones	136	Route options	142	SmartLink	175
equalizer	136	SmartLink+	141, 146	Android Auto	176
infotainment	136, 144	Software updates	145	Apple CarPlay	177
Reset to factory settings	202	Sound	144	Introduction to the subject	175
Software Update	135	System information	138, 145	Main menu	176
sound	136	ŠKODA Connect	138	MirrorLink®	178
sound system	136	Tank options	143	SmartLink+	
surround	136	Telephone	146	Set	141, 146
system information	135	Time and date	136, 144	ŠKODA OneApp application	179
ŠKODA Connect	145	Top speeds	143	SMS	
vehicle	202	Units	137, 144	Main menu	170
Settings		Update software	138	New message	170
Additional keypad languages	137, 144	User profile	168	Received message	171
Advanced settings	143	Video DVD	140	Snow chains	279
APN	138, 166	Voice control	137	Sockets	
Bluetooth	138, 140, 145	Volume	131	12-volt socket in the interior	100
Codecs	140	WLAN	138	12 volt socket in luggage compartment	101
Configuration wizard	132	Settings Call		230 V	101
DAB	139, 146	Clear calls SettingsText messages	140	Software Update	135, 138
Data connection	138	Set to		Software updates	145
External device data transfer	137, 144	Auxiliary heating (auxiliary heating and ventilation)	122	SOS button	16
FM	139, 145	Side compartments in the luggage compartment	110	sound	136
Images	140	SIM card		Sound	144
Information regarding the version of the navigation data	143	Change PIN code	166	sound system	136
Infotainment language	137, 144	Data Connection	173	Spare wheel	278
Infotainment screen	136, 144	Insert	166	Removing / stowing	284
Manage favourites	168	PIN code	166	Speed limitations	195
Manage memory	142	Remove	166	speed limiter	
Map	142	Sleep package		activate	236
Media	140, 146	Blanket	100	lever	236
Navigation	142			Lever with ACC	236
Nav. announcements	143			Speed limiter	44, 235
Network	138			Speed regulating system	
Phone	140			Warning light	44

Text messages (SMS) _____	170	Towing protection _____	62	Turning off Infotainment _____	130
User profile _____	146	Towing the vehicle _____	289	Turning on Infotainment _____	130
Voice control _____	133	Traction control (ASR) _____	218	Turn signal _____	71
Voicemail _____	167	Traction control (TCS) _____	41	Turn signal system	
Telephone book _____	167	traffic		Warning light _____	44
Telephone compatibility _____	163	Detail of the traffic report _____	201	Tutorial videos _____	11
Telephone connection types _____	164	Traffic		Type plate _____	304
Telephone functions _____	167	List of traffic reports _____	200	Tyre load capacity _____	279
Telephone number _____	167	Traffic Information (TMC) _____	201	Tyre pressure _____	277
Telephone Premium		Traffic jam _____	202	Warning light _____	43
rSAP _____	163	Traffic jam assistant _____	249	Tyre pressure monitor	
Text messages _____	170	Traffic obstruction _____	202	refer to the tyre pressure monitoring _____	252
Through-loading bag _____	99	Traffic program (TP) _____	149	Tyre pressure monitoring _____	252
Tilt / slide sunroof		Traffic reports (TMC) _____	200	Warning light _____	43
Sunblind _____	69	Traffic sign recognition _____	250	Tyre Pressure Monitoring	
Tilting / sliding sunroof		Traffic signs		Storing the tyre pressure values and Infotainment display _____	253
Operation _____	68	see Traffic sign recognition _____	250	Tyre repair _____	286
Time _____	49, 136, 144	Trailer		Tyres _____	276
Time and date display in the Infotainment screen _____	130	Connect and disconnect _____	255	damage _____	276
Tiptronic _____	213	Load _____	256	Explanation of the label _____	279
Tire		loading _____	256	new _____	276
Wear indicator _____	278	Towing a trailer _____	257	Tyre pressure _____	277
TMC		Trailer stabilisation system (TSA) _____	219	Tyre size _____	279
Detail of the traffic report _____	201	Trailer towing _____	254		
dynamic route _____	201	navigation _____	194	U	
List of traffic reports _____	200	Trailer towing device		Units _____	137, 144
Tools _____	282	Handling _____	254	Unlock	
Top speeds _____	143	Warning message _____	254	Individual settings _____	60
TOP TETHER _____	33	Transit point _____	197	KESY _____	59
Touch screen _____	127	transmitter		Unlocking	
Towing _____	289, 290	See main menu _____	147	Central locking button _____	59
Towing a trailer _____	257	Transport		in case of emergency _____	293
Towing device		Luggage compartment _____	105	Remote control _____	58
Accessories _____	254	Roof racks _____	116	Unlocking and locking _____	57
Vertical load _____	254	Towing device and trailer _____	254	Unlock steering lock _____	204
Towing eye _____	290	Transporting children _____	29	Update navigation data _____	181
		Triangle _____	281	Update the navigation data _____	143
		TSA _____	219		

USB	94, 153	Video DVD		Waste container	95
Safe removal	144	Compatible sources	159	Water in the fuel filter	47
Useful equipment		Main menu	158	Waypoint mode	198
Clothes hook	98	Play back	158	Main menu	198
Cup holders	94	Supported file formats	159	Record waypoints	199
Removable through-loading bag	99	Video DVD menu	158	Set waypoint manually	199
Useful links	2	Menu	158	Waypoint tour memory	199, 200
User account		video player	158	Waypoint tour memory	199, 200
Configuration wizard	132	VIN		Weather conditions	259
User profile	140, 146	Vehicle Identification Number	304	Weights	304, 305
V					
Variable loading floor	113	Virtual pedal		Wheel bolts	
vCard	186, 188	see operating contactless boot lid	65	Anti-theft wheel bolts	285
Vehicle - Settings	202	Visibility	77	Caps	284
Vehicle battery		Visors	78, 79	Loosening and tightening	285
charging	275	Voice amplification	131	Wheels	276
Safety instructions	274	Voice control	133	Changing	283
Warning light	45	Commands	134	Full trim	284
Vehicle care		Correction of a voice command input	134	Load Index	279
Exterior	263	Help	134	Snow chains	279
Outside	262	Not recognising a voice command	134	Speed symbol	279
Vehicle cleaning		on / off	133	Tyre age	276
Exterior	263	Operation principle	134	Tyre damage	276
Windscreens	263	Settings	137	Tyre pressure	277
Vehicle condition		Stop / restore command	134	Tyre storage	276
Auto-Check-Control	49	Voiceemail	167	Uni-directional tires	276
Vehicle dimensions	306, 307	Volume	131	Winter tyres	279
Vehicle height	306, 307	Volume setting	131	Window	
Vehicle Identification Number (VIN)	304	W			
Vehicle length	306, 307	Waiter		operation	66
vehicle systems	202	Voice control	134	Window convenience operation	67
Vehicle tool kit	282	Warning lights	39	Window operation	66
Vehicle width	306, 307	Warning symbols		Windscreen - heating	77
Ventilation		see Warning lights	39	Windscreen washer fluid	
Seats	89	Warning triangle	281	Refill	271
Vest	281	Warning when speeding	52	Warning light	47
		Warranty	6	Windscreen washing system	79
		Washing the vehicle	261	Windscreen wipers and washers	79
				Activation	80
				Replacing the windscreen wiper blade	295

Replacing the windscreen wiper blades _____	294	Xenon headlight _____	72
Service position of the windscreen wiper arms _____	294	Other Characters	
Winter operation _____	279	ŠKODA Connect	
All season tyres _____	279	register _____	145
Car battery _____	275	Register _____	138
Diesel fuel _____	267	see Online Services _____	13
Snow chains _____	279	services Manager _____	145
Winter tyres _____	279	Services Manager _____	138
Winter tyres _____	279	Set _____	138
Wiper and Washers		set to _____	145
Automatic rear window wipers _____	80	ŠKODA Connect Online Services	
Wipers and washer		Enable services _____	138
Warning light for windscreen washer fluid level _____	47	Register _____	138
Wipers and washers		ŠKODA OneApp application _____	
Activate _____	80		179
Refill fluid _____	271		
Wiping interval _____	80		
Wireless Internet Hotspot			
set to _____	138		
Wizard for blind spot monitoring _____	223		
Driving situations and warnings _____	224		
Operation _____	224		
WLAN _____	154, 173		
Client _____	174		
Connect _____	174		
Connect to hotspot _____	174		
Set hotspot _____	174		
Switch hotspot on/off _____	173		
WPS _____	138, 174		
WLAN client			
set to _____	138		
WLAN Client _____	174		
WPS _____	138, 174		
X			
XDS _____	218		

Reprinting, duplicating, translating and any other use, either in whole or in part, is not permitted without the written consent of ŠKODA AUTO a.s.

ŠKODA AUTO a.s. expressly reserves all rights relating to copyright laws.

Subject to change.

Issued by: ŠKODA AUTO a.s.

© ŠKODA AUTO a.s. 2018

www.skoda-auto.com

Návod k obsluze
Superb anglicky 11.2018
3V0012720AJ



3V0012720AJ